

Makita®



2022.10

GENERAL CATALOGUE
KATALOG PRODUK 综合产品目录

XGT
40V Li-ion
max

XGT X2
80V max





Makita
60Ah 18V
Lithium-ion



Teknologi Ekstrim Litium-ion
锂离子技术

18V LITHIUM-ION

18V Lithium-ion | 18V 锂离子



Chain Saw

Pole Saw

Pruning Shears

Grass Trimmer

Earth Auger

Lawn Mower

Vacuum Cleaner

Blower

Portable Power Pack

High Pressure Washer

Vacuum Pump

Impact Wrench

Kettle

Hedge Trimmer

Backpack Vacuum Cleaner

Multi Function Power Head

Mixer

Screwdriver

4 Mode Impact Driver

Upright Cleaner

Auto Feed Screwdriver

Oil-Pulse Driver

Driver Drill

18V x2

Angle Drill

Angle Impact Wrench

Impact Driver

380+

TOOLS

6.0Ah 5.0Ah 4.0Ah
3.0Ah 2.0Ah 1.5Ah

Hammer Driver Drill

Rotary Hammer

Power Scraper

Combination Hammer

Multi Tool

Steel Rod Cutter

Metal Shear

Compact Cut Off

Metal Cutter

Recipro Saw

Nibbler

Die Grinder

Threaded Rod Cutter

Cutter

Circular Saw

Sander Polisher

Drywall Sander

Finishing Sander

Random Orbit Polisher

Portable Band Saw

Slide Compound Miter Saw

Random Orbit Sander

Angle Grinder

Compound Miter Saw

Compound Miter Saw

Jig Saw

Expand Your Lithium Line Up

INDEX Indeks 索引

CORDLESS Tanpa Kord 充电式	26 - 132
LED FLASHLIGHT Lampu Suluh LED LED照明灯	133 - 140
VACUUM CLEANER Pembersih Vakum 吸尘器	141 - 174
DRILLING FASTENING Gerudi Pengetat 钻孔 紧固	175 - 180
IMPACT DRILLING DEMOLITION Gerudi Pemecah 石工钻孔 凿裂加工	181 - 191
CUTTING Pemotong 切割	192 - 198
GRINDING SANDING Pengisar Pelicin 研削 研磨	199 - 217
SAWING Gergaji 锯切	218 - 225
PLANING ROUTERING Pengetam Tanggam 刨削 雕刻	226 - 229
OTHERS Lain-lain 其他	230 - 232
OUTDOOR POWER EQUIPMENT Alatan Kerja Luar 园林·户外	233 - 236
Makita mit	237 - 246
1	
1805N	226
1911B	226
2	
2012NB	227
2107F	196
2416S	197
2704	220
2712	221
3	
3501N	227
3600H	229
3612BR	229
3709	228
3901	227
4	
4100KB	195
4100NH	192
4100NH2Z	195
4100NH3Z	195
4107R	195
4112HS	192
4114S	192
4131	192
4300BV	224
4327	224
4327M	224
4329	223
4350CT	223
4351CT	223
4403	229
5	
5008MG	222
5016B	233
5103N	222
5402	223
5806B	222
6	
6016	176
6305	175
6412	175
6413	175
6905B	179
6906	179
6922NB	180
6924N	180
9	
9031	216
9035H	216
9045B	216
9215SB	210
9237C	211
9401	215
9404	215
9553HBG	199
9553HNG	199
9556HNG / HN / NB	200
9556HPG	200
9557HNG / NBG	202
9557HPG	202
9558HNG / NBG	204
9558HPG	204
9565CR / PC	205
9903	215
9911	215
9924DB	215
A	
ADP001G NEW	126
ADP05	127
ADP06	127
ADP08	127
AF353	230
AF506	230
AF601	230
AF635	230
AS001GA105 / GZ03	39
AT638A	230
B	
BBC231UZ	121
BML360	121
BO3710	216
BO4510H	217
BO4556	217
BO4901	216
BO5031	217
BO5041	217
BO6050J	217
BUH550RD / Z UH550DWB	121
BUH650RD / Z UH650DWB	121
BUN490RD	121
C	
CA5000X	198
CB100DB	132
CC300DW / DZ	118
CC301DWME / DWAE / DZ	111
CE001GZ01 NEW	37
CF100DZ	124
CF101DZ	124
CG100DZA	112
CL001GA127 / GA116 / GZ04 / GZ10	148
CL002GA117 / GA104 / GZ03 / GZ07 NEW	148
CL070DZ	154
CL100DW / DZ	153
CL102DW / DZ	154
CL104DWYX / DWY	154
CL105DW / DWX	154
CL106FDWYW / FDZW	153
CL107FDWYW / FDZW	153
CL108FDWYW / FDZW	153
CL111DWI / DWR	154
CL114FDWI	153
CL121DZ	152
CP100DWA / DZ	110
CS002GZ NEW	36
CW001GZ	125
D	
DA001GZ	28
DA3010F	176
DA332DWAE / DZ	110
DBO180Z	89
DBO380RTJ / Z	88
DBS180Z	88
DCB200B	132
DCC500Z	82
DCE090Z	51
DCF102Z	124
DCF201Z	124
DCF203Z	124
DCG180RFE / RFEB / ZB / Z	96
DCL180FRFW / RFB / ZB / Z	151
DCL181FZWX	151
DCL182FRFW / FZW	152
DCL184Z	152
DCL280FZW / FZB / FZ	151
DCL281FZW / FZB / FZ	151
DCL282FZW / FZ	151
DCL500Z	147
DCL501Z	147
DCM501Z	127
DCO180Z	94
DCO181Z	93
DCS550RFE / Z	78
DCS551RFJ / Z	78
DCS552Z	78
DCS553Z	78
DCU180Z	104
DCV202YXL	132
DDA351Z	71
DDA450Z	70
DDA460ZK	48
DDF083RTE / RFE / Z	62
DDF453RME / RFE / SYE / Z	62
DDF458RME / RFE / Z	61
DDF459RME / Z	61
DDF481RTE / RME / RFE / Z	60
DDF482RME / RFE / Z	61
DDF483RME / RFE / Z	62
DDF484RTE / RME / RFE / Z	61
DDF485RFE / Z	61
DDF486RTE / Z	60
DDF487RAJ / Z	62
DDG460ZX7	58
DF001DW	119
DF001GD201 / GZ	27
DF002GD201 / GA201 / GZ	27
DF012DSE	119
DF0300	175
DF031DWAE / DWYE / DZ	106
DF032DSME / DSAE / DZ	105
DF033DSME / DWAE / DZ	105
DF330DWE	117
DF331DSME / DZ	105
DF332DSME / DSAE / DZ	105
DF333DSME / DWAE / DWYE / DZ	105
DF488DWE	120
DFJ211ZM / ZL / ZXL	129
DFJ212ZM / ZL / ZXL	130
DFJ213ZM / ZL / ZXL	130
DFJ214ZM / ZL / ZXL	130
DFJ2140M / L / XL / 2XL	130
DFJ216ZL	129
DFJ300ZXL	131
DFJ311ZM / ZL / ZXL	129
DFJ400ZXL	131
DFJ411ZM / ZL / ZXL	129
DFJ416ZL	129
DFN350Z	95
DFR550Z	71
DFS250RTE / RFE / Z	71
DFS251RTE / RFE / Z	71

Double Insulation
Penebat Berganda | 双重绝缘

Variable Speed
Kelajuan Boleh Ubah | 无段变速

Brake
Brek | 电子自动刹车

Reversing
Mengundur | 正逆转

Mechanical 2-Speed
2-kelajuan Mekanikal | 机器式双速

Electronic 2-Speed
2-kelajuan Elektronik | 电子式双速

Electronic 3-Speed
3-kelajuan Elektronik | 电子式三速

Electronic 4-Speed
4-kelajuan Elektronik | 电子式四速

Keyless Chuck
Chuck Pengetatan Diri | 自锁夹头

Torque Setting 6
Pelarasan Tork 6 | 6档扭力调整

Torque Setting 9
Pelarasan Tork 9 | 9档扭力调整

Torque Setting 16
Pelarasan Tork 16 | 16档扭力调整

DFS452Z	71	DHS680RMJ / RFJ / Z	90	DMP180Z	96	DTR180ZJ	81
DFV210ZM / ZL / ZXL / Z2XL	131	DHS710RM2J / RF2J	51	DMP181Z	96	DTS141RFE / Z	70
DFV214A01 / A02	131	DHS782Z	50	DMR114	123	DTW152Z	120
DG001GZ05	43	DHS783Z	50	DMR203	123	DTW180Z	75
DGA402RFE / Z	85	DHS900PT2 / Z	50	DMR300	123	DTW181RFE / Z	75
DGA404RTE / RFE / Z	84	DHW080ZK	59	DP2010	175	DTW190RFX2 / RFE / Z / ZX	75
DGA405RFE / Z	85	DJN161Z	79	DPB180Z	82	DTW251RME / RFE / Z	75
DGA406RME / RFE / Z	84	DJR181RFE	91	DPB182Z	82	DTW285RFE / Z	74
DGA408RME / RFE / Z	84	DJR183Z	91	DPB183Z	82	DTW300RTJ / Z	74
DGA411Z	84	DJR186RME / RFE / Z	91	DPB184Z	82	DTW301RTJ / Z	74
DGA414Z	83	DJR187RME / RFE / Z	91	DPJ180Z	93	DTW302RTJ / Z	74
DGA418Z	83	DJR188Z	91	DPO500Z	87	DTW450RME / RFE / Z	74
DGA419Z	84	DJR360RF4 / Z	49	DPO600Z	87	DTW700RTJ / Z	73
DGA452RME / RFE / Z	85	DJS101Z	79	DPP200ZK	79	DTW701RTJ / Z	73
DGA456RFE / Z	85	DJS130RFE / Z	78	DPT353Z	95	DTW800RMJ / RFJ / Z	73
DGA458RFE / Z	85	DJS161Z	79	DPV300Z	88	DTW1001RTJ / RMJ / RFJ / Z	73
DGA505RFE / Z	87	DJV180RFE / Z	92	DRC200Z	146	DTW1002RTJ / RMJ / RFJ / Z	73
DGA508RFE / Z	86	DJV181RFE / Z	92	DRS780Z	51	DUA300ZB	56
DGA511Z	86	DJV182RME / RFE / Z	92	DRT50Z / ZJX9	94	DUA301ZB	55
DGA514Z	86	DJV184RFJ / Z NEW	92	DRV150Z	79	DUB184RT / Z	103
DGA518Z	86	DKP180RFE / Z	93	DRV250Z	79	DUB185Z	104
DGA519Z	86	DKP181RTJ / Z	93	DS4012	176	DUB186Z	103
DGA700Z	49	DKT360Z NEW	126	DS5000	176	DUB361Z	58
DGA701Z	49	DLM160Z	101	DSC102ZJ	80	DUB362RT2 / RM2 / Z	57
DGA900Z	49	DLM230SF / Z NEW	101	DSC121ZK	80	DUB363ZV	57
DGA901Z	49	DLM330SM / Z	101	DSC162Z	80	DUC252Z	57
DGD800Z	87	DLM380Z	55	DSC163ZK	80	DUC254Z	103
DGD801Z	87	DLM382PT2 / CM2 / Z	55	DSC191Z	81	DUC353Z	56
DGP180RT / Z	93	DLM431PT2 / Z	55	DSC251ZK	81	DUC355Z	56
DHG180ZK NEW	97	DLM432PT2 / Z	54	DSD180Z	92	DUC356Z	56
DHG181ZK NEW	97	DLM460Z	54	DSL800Z	88	DUC406Z	56
DHK180Z	77	DLM480Z	54	DSL801Z	88	DUH523RME / RFE / Z	102
DHP453RME / RFE / SYE / Z	65	DLM532Z	54	DSP600Z	51	DUH601Z	102
DHP458RME / RFE / Z	64	DLM533Z	53	DSP601Z	51	DUH651Z	57
DHP459Z	65	DLM539Z	54	DST121ZK	95	DUH754SRT / SZ	101
DHP481RTE / RFE / Z	64	DLS111Z	50	DST221Z	95	DUM111SYX	103
DHP482RME / RFE / Z	64	DLS211Z	50	DST421ZK	95	DUM604Z	103
DHP483RME / RFE / Z	66	DLS600Z	89	DTD149RFE / Z	69	DUN461WZ	102
DHP484RME / RFE / Z	64	DLS713RME / Z	90	DTD152RME / RFE / Z	69	DUN500WZ	102
DHP485RFE / Z	65	DLS714PM2 / Z	50	DTD153RTE / RFE / Z	68	DUN600LZ	102
DHP486RTE / Z	64	DLW140Z	49	DTD154RME / RFE / Z	68	DUP361Z	53
DHP487RAJ / Z	66	DML186	139	DTD155RME / Z	69	DUP362ZN	52
DHR165RME / RFE / Z	77	DML801	138	DTD156SF / Z	69	DUR181Z	100
DHR171RTE / RFE / Z	77	DML805	136	DTD157RAJ / Z	69	DUR182LRF / LZ	100
DHR182ZWJ	77	DML807	138	DTD170RME / RFE / Z	68	DUR184LZ	100
DHR202RME / RFE / Z	76	DML808	137	DTD171RTJ / RFJ / Z	68	DUR187LRF / LZ	100
DHR241RFE / Z	76	DML810	135	DTD172RTJ / Z NEW	68	DUR188LRF / LZ	99
DHR242RTE / RME / RFE / Z	76	DML812	136	DTL061Z	70	DUR188URFE	100
DHR263PM4 / Z	48	DML813	135	DTL062Z	120	DUR189Z	99
DHR280PT2J / Z	47	DML814	135	DTL063Z	76	DUR190LRT2 / LZK2	99
DHR282PT2J / Z	47	DML815	137	DTM50Z	89	DUR191LRT2 / LZK2	99
DHR400ZKN	47	DML809	135	DTM51RFEEX8 / Z	89	DUR192LST / LZ	99
DHS630RFE / Z	90	DML811	136	DTM52RTJX1 / Z	89	DUR193RF / Z NEW	98
DHS661RFJ / Z	90	DML816X	138	DTP141RFE / Z	70	DUR194SFX1 / ZX1 NEW	98

Torque Setting 18
Pelarasan Tork 18 | 18档扭力调整

Torque Setting 20
Pelarasan Tork 20 | 20档扭力调整

Torque Setting 21
Pelarasan Tork 21 | 21档扭力调整

SDS-PLUS Shank
Batang SDS-PLUS | 四坑柄

SDS-MAX Shank
Batang SDS-MAX | 五坑柄

17mm Hex Shank
Batang Heksagon 17mm | 17mm六角柄

30mm Hex Shank
Batang Heksagon 30mm | 30mm六角柄

21mm Hex Shank
Batang Heksagon 21mm | 21mm六角柄

28.6mm Hex Shank
Batang Heksagon 28.6mm | 28.6mm六角柄

Torque Limiter
Pengehad Tork | 扭力限制器 (安全离合器)

Constant Speed
Kelajuan Tetap | 电子定速

Soft Start
Penghidupan Secara Perlahan | 缓速启动

DUR364LPM4 / LRM2 / LZ	52	GA021GM201 / GD201 / GZ	30	GS6000	213	HR3001CJ	184
DUR368APT2 / AZ	52	GA023GM201 / GD201 / GZ	31	GV5010	210	HR3011FCJ	184
DUR368LPT2 / LZ	52	GA027GM201 / GD201 / GZ	31	GV6010	210	HR3200C	184
DUR369LZ	52	GA029GM201 / GD201 / GZ	32	GV7000C	210	HR3210C	184
DUS054Z	104	GA035GZ	32	H		HR3530	184
DUT130RFE / Z	77	GA036GZ	32	HB350	180	HR4001C	185
DUT131Z	77	GA037GT201 / GM201 / GZ	32	HB500	180	HR4002	185
DUX18RGX4 / Z	101	GA038GT201 / GM201 / GZ	33	HG5030K	231	HR4003C	185
DUX60ZM3 / Z	53	GA042GM201 / GD201 / GZ NEW	31	HG6031VK	231	HR4013C	185
DVC150LZ	143	GA044GM201 / GD201 / GZ NEW	32	HG6530VK	231	HR4030C	185
DVC151LZ	143	GA4030	199	HK1820	189	HR4501C	186
DVC152LZ	143	GA4030R	199	HM001GM202 / GZ	26	HR4511C	186
DVC153LZ	143	GA4031	200	HM002GZ03	26	HR5202C	186
DVC154LZ / LZX	143	GA4034	200	HM0810TA	187	HR5211C	186
DVC155LZX3	144	GA4040	200	HM0870C	187	HR5212C	186
DVC157LZX5	144	GA4040C	201	HM0871C	187	HS004GM201 / GZ	35
DVC260Z / ZX	146	GA4041C	201	HM1201	187	HS009GT201 / GZ	34
DVC261Z	146	GA4051R	201	HM1203C	188	HS011GT201 / GZ NEW	34
DVC265ZX	146	GA4530	201	HM1213C	187	HS0600	222
DVC350Z	152	GA4530R	202	HM1214C	188	HS100	232
DVC560Z	147	GA4540	202	HM1306	188	HS300DW	118
DVC660Z	145	GA4540R	202	HM1307C	188	HS301DSME / DWAE / DZ	111
DVC665Z	145	GA4541C	203	HM1317C	188	HS6100	221
DVC750LZX1	152	GA5010	204	HM1501	189	HS6600	221
DVC860LZ	144	GA5020	204	HM1511	189	HS7010	221
DVC862LPT2 / LRT2 / LZ	144	GA5030	203	HM1810	189	HS7600	221
DVC863LPT2 / LRT2 / LZ	144	GA5030R	203	HM1812	189	HW102	236
DVC864LZ	145	GA5034	203	HP001GD201 / GZ	28	HW1200	236
DVC865LZX3	145	GA5040	204	HP002GD201 / GA201 / GZ	28	HW1300	236
DVC867LZX1	145	GA5041C	205	HP0300	181	J	
DVF154Z	104	GA5080R	205	HP1230	181	JN1601	197
DVP180Z	94	GA6010	205	HP1630	181	JN3201	197
DVP181ZK NEW	94	GA6020C	206	HP2050	181	JR001GM201 / GZ	35
DVR450Z	96	GA7020	207	HP330DWE	117	JR002GM201 / GZ NEW	35
DWR180Z	76	GA7050	206	HP331DSME / DWAE / DWYE	106	JR100DWE	118
DWT310ZK	48	GA7060	207	HP332DSME / DSAE / DZ	106	JR102DWE	119
E		GA7060R	207	HP333DSME / DWAE / DWYE / DWY / DZ	106	JR105DWAE / DZ	112
ELM3320	234	GA7061R	207	HP488DWE	120	JR3050T	224
ELM3720	234	GA7062	207	HR001GM201	26	JR3051TK	225
ELM4121	234	GA7063R	206	HR002GM201	27	JR3061T	225
F		GA7070	208	HR003GM201 / GZ	27	JR3070CT	225
FJ203DZL / DZLL	131	GA9020	209	HR005GM201 / GZ	26	JS1300	198
FJ301DZM / DZL / DZLL	131	GA9050	208	HR006GZ	26	JS1601	198
FJ401DZL / DZLL / DZ3L	131	GA9060	209	HR007GM201 / GZ	27	JS1602	198
FJ502DZM / ZL / ZLL	130	GA9060R	208	HR140DWYE1	108	JS3201	198
FN001GD101 / GZ	38	GA9061R	208	HR166DSMJ / DWAJ / DZ	108	JV0600K	224
FS2300	177	GA9070	209	HR1830	182	JV100DWE	118
FS2500	178	GB602	213	HR1840	182	JV101DWAE / DWYE / DZ	111
FS2700	178	GB801	214	HR1841F	182	JV102DZ	112
FS4200	178	GD0600	211	HR2020	182	JV103DSMJ / DWAJ / DZ	112
FS6300	178	GD0601	212	HR2320T / X2	182	K	
G		GD0603	212	HR2470X5	183	KP001GM201 / GZ NEW	38
GA003GM201 / GD201 / GZ	30	GD0800C	212	HR2630X3	183	KP0800X	226
GA005GM201 / GD201 / GZ	31	GD0801C	212	HR2631FTX2	183	KP0810	226
GA011GM201 / GD201 / GZ	30	GD0811C	212	HR2652	183	L	
GA013GM201 / GD201 / GZ	31	GS5000	213	HR2810	183	LB1200F	225

 **Bevel Cutting L45 R5**
Pemotongan Serong Kiri 45° Kanan 5° | 斜角切割(左45°/右5°)

 **Bevel Cutting 45 left**
Pemotongan Serong Kiri 45° | 斜角切割(左45°)

 **Bevel Cutting 45 LR**
Pemotongan Serong Kiri Kanan 45° | 斜角切割(左右各45°)

 **Orbital Cutting**
Pemotongan Orbit | 轨道切割

 **Makita Shank Jig Saw Blade**
Bilah Gergaji Ukir Makita | M型式锯片

 **Bayonet Shank Jig Saw Blade**
Bilah Gergaji Ukir Jenis Bayonet | B型曲线锯锯片

 **Laser Marker**
Penanda Laser | 雷射标志

 **Hook & Loop**
Strap Velcro | 魔术贴式

 **Depth Adjustment**
Pelarasan Kedalaman | 深度调整

 **Anti Vibration**
Anti Getaran | 防震

 **Automatic Oiling**
Fungsi Pelinciran Automatik | 自动润滑功能

 **Chain Brake**
Brek Rantai | 链条刹车



XGT is a new system with its own tools, batteries, and chargers. A combination of innovative tool design and higher output batteries provide a genuine solution for high demand industrial users.

XGT adalah sistem baru dengan alat, baterai dan pengecas yang unik. Kombinasi reka bentuk alat inovatif dengan baterai output tinggi memberikan penyelesaian bagi pengguna industri permintaan tinggi. 采用全新的XGT智能充电供电系统，具有独特的工具、电池和充电器。创新的工具设计和高输出的电池相结合，为高需求的工业用户提供了真正的解决方案。

Tool ◀▶ Battery ◀▶ Battery Charger Digital communication

Alat Kuasa ◀▶ Bateri ◀▶ Pengecas Bateri | 工具 ◀▶ 电池 ◀▶ 充电器
Komunikasi digital 数码通讯



Optimum power supply system and Optimum charging system

The XGT range of tools and batteries come with a built-in program, providing digital communication between the battery and tool. Allowing not only for the battery to talk with tool but also the tool to talk to the battery. Battery technology and motor engineering that work together for optimum performance.

Sistem Bekalan Kuasa dan Pengecasan Pintar XGT
Bateri alat kuasa siri XGT mempunyai program terpasang untuk mewujudkan komunikasi dua hala antara bateri dan alat kuasa. Prestasi yang optimum dicapai dengan komunikasi antara teknologi bateri dan kejuruteraan motor yang berfungsi bersama XGT智能充电供电系统
XGT系列产品工具的电池都有一个内置程序，实现电池与工具之间双向的通信，使电池和电机达到理想的性能。

Optimum charging system

Auto maintenance system with two cooling fans for providing more optimum fast charging
Sistem pengecasan pintar
Pengecas mempunyai sistem penyelenggaraan automatik dan mempunyai dua kipas penyejuk
智能充电系统
充电器具有自动维护系统，并且拥有两个冷却风扇

Built Tough

High durability specifications specially designed for 40Vmax Li-ion batteries
Spesifikasi ketahanan tinggi direka khas untuk bateri Li-ion 40Vmax
专为 40Vmax 锂电池设计的高耐用性结构

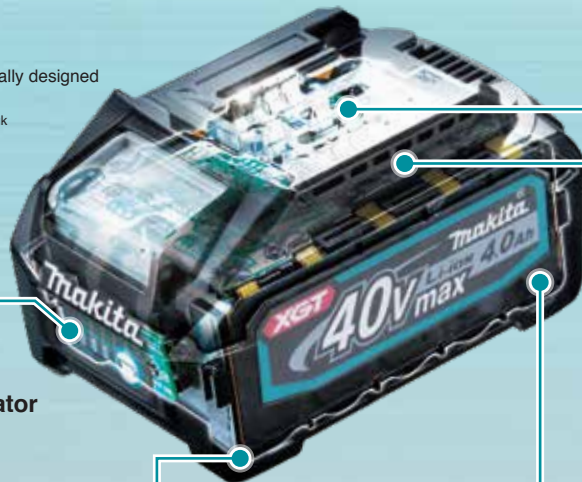

4-LED fuel gauge indicator

Penunjuk tahap bateri
电池电量计指示灯



Heavy duty outer casing and cell holder

Bekas lindung dan alas bateri yang kukuh 坚固的外壳和电池架
Create a space to absorb impact
Ruang tambahan untuk menyerap hentaman
创造额外吸收冲击力的空间

Shock absorption structure

Struktur penyerapan kejutan
减震结构

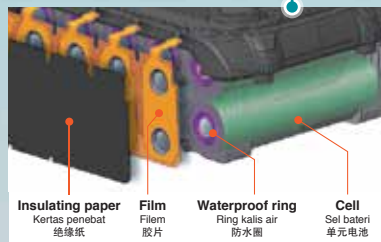

Waterproof Triple-layer Structure

prevents cell failure due to water and dust
Struktur kalis air tiga lapisan
Mencegah kerosakan bateri akibat air dan habuk
三层防水结构
防止因水和灰尘引起的电池故障



Terminal short-circuit prevention structure

The protection wall is provided between terminals against water and dust
Struktur pencegahan litar pintas terminal
Terdapat dinding pelindung kalis air dan tahan debu di antara terminal
端子防短路结构
端子之间设有防水防尘保护墙



High Rigidity Battery Rails

Durable slide in battery rail that holds the battery and the tools firmly and securely to withstand high power products
Slaid bateri berkekuatan tinggi
Slaid tahan lama di rel bateri untuk pegangan bateri dan alat kuasa dengan kukuh, sesuai untuk kerja yang berbeban tinggi
高强度电池滑轨
耐用的滑动式滑轨，可牢固地连接电池和工具，更适合高负荷的工作

OPTIMUM CHARGING SYSTEM

Sistem Pengisian Terbaik 智能充电系统



• It is necessary to cool down before start charging when the battery temperature is high
Bateri yang baru diguna bersuhu tinggi, ia perlu didinginkan sebelum pengisian bermula
刚使用完的电池处于高温状态, 要冷却后才能开始充电

• Built-in fan circulates air through the battery before start charging and during the charging process to cool the battery for faster charge time
Kipas akan terus menyejukkan bateri semasa pengisian untuk mencapai pengisian cepat
开始充电后, 风扇会持续冷却电池, 令充电时间更短

FAST CHARGING
Pengisian Cepat 快速充电

22 MINUTES
to fully charge a 3.0Ah slide Li-ion battery

*Charge time may vary depending on battery model or conditions of use
Masa pengisian mungkin berbeza bergantung kepada model bateri atau syarat penggunaan
充电时间可能因电池型号或使用条件而异

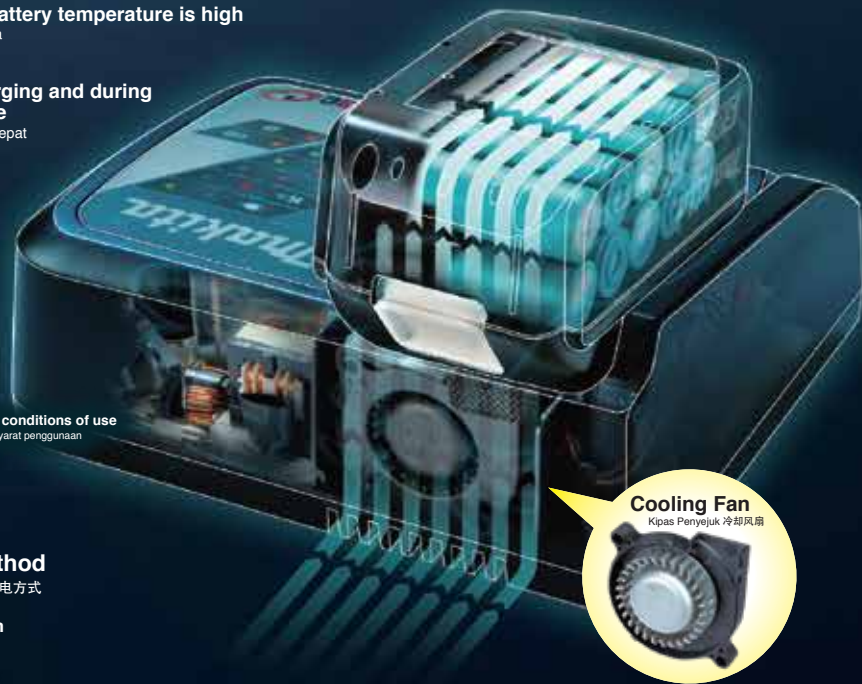

Makita
Optimum charging system
Sistem Pengisian Terbaik 智能充电系统

Forced air cooling



Fast charging



Optimum charging system

Sistem Pengisian Terbaik 智能充电系统

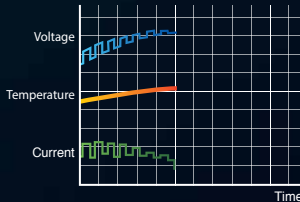

Competitor
General charging method
Kaedah Pengisian Umum 一般充电方式

Natural heat dissipation



Waiting time for charging



General charging method

Kaedah Pengisian Umum 一般充电方式

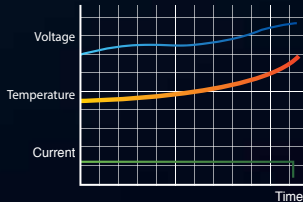

The Makita Rapid Optimum Charger communicates with the battery's built-in chip throughout the charging process to optimize battery life by actively controlling current, voltage and temperature

Makita Pengisian berkomunikasi dengan setiap sel unit dan mengawal arus, voltan dan suhu, membolehkan pengisian pantas dan memanjangkan hayat bateri

Makita充电器与每个单元电池进行通信并控制电流, 电压和温度, 实现了快速充电, 且延长电池使用寿命

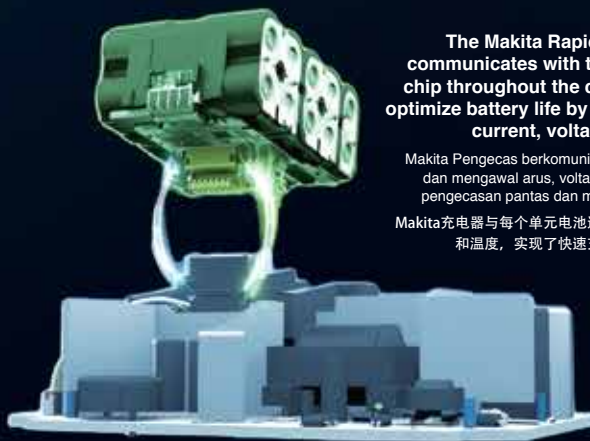

BATTERY PROTECTION FUNCTION

Fungsi Perlindungan Bateri 电池保护功能

Shock Absorbing

Tahan getaran 坚固防震

Heavy Duty Pack

Pembungkusan tugas berat

重型包装

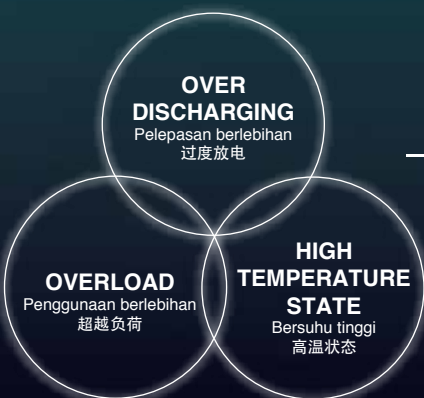

Built-In-CPU

CPU dibina dalam 内置CPU



Anytime Charge

Caj pada bila-bila masa 随时充电

- No Memory Effect
Tiada Kesan Memori 不受记忆影响
- No Discharging Required
Tiada pelepasan diperlukan 不需要放电



Teknologi Ekstrim Litium-ion
锂离子技术



12V Lithium-ion
12V 锂离子



12Vmax
VIDEO CLIP
Models and specs may vary by country.



Teknologi Ekstrim Kompak
紧凑极限技术



64Vmax Lithium-ion
64Vmax 锂离子

Battery & Charger

Battery fuel gauge



Assist handle

- assists easy installation/removal of the battery from the lawn mower or battery charger.
- allows for easy transportation of the battery to job site.



BL6440 (4.0Ah)
(191R06-8)

Charging Time



BL6440 (4.0Ah)
(191R06-8)



DC64WA
(191W23-8)

120 min

DC64WA
(191W23-8)



BATTERY & CHARGER TIME REFERENCE, COMPATIBILITY CHART

Panduan tempoh pengecasan dan bateri 电池充电时间参考表, 兼容性图表

	<p>5.0Ah BL4050F (191L47-8)</p>	<p>4.0Ah BL4040 (191B26-6)</p>	<p>2.5Ah BL4025 (191B36-3)</p>	<p>2.0Ah BL4020 (191L29-0)</p>
	<p>Fast Charger DC40RA (191E08-6) Pengecas Pantas 快速充电器</p>	<p>50 min. Fast Charging</p>	<p>45 min. Fast Charging</p>	<p>28 min. Fast Charging</p>
<p>Standard Charger DC40RC (191M92-9) Pengecas Standard 标准充电器</p>	<p>85 min.</p>	<p>67 min.</p>	<p>38 min.</p>	<p>30 min.</p>

	<p>Fast Charger DC40RA (191E08-6) Pengecas Pantas 快速充电器</p>	<p>Adapter ADP10 (191C11-5)</p>	<p>Two Port Multi Rapid Charger DC18RD (196934-4) (630869-4) Pengecas Pantas Dua Port 两端快速充电器</p>	<p>Standard Charger DC18SD (194534-4) Pengecas Standard 标准充电器</p>
	<p>6.0Ah BL1860B (197422-4)</p>	<p>40 min.</p>	<p>55 min. Fast Charging</p>	<p>130 min.</p>
	<p>5.0Ah BL1850B (197282-4)</p>	<p>40 min.</p>	<p>45 min. Fast Charging</p>	<p>110 min.</p>
	<p>4.0Ah BL1840B (197265-4) (197267-0)</p>	<p>29 min.</p>	<p>36 min. Fast Charging</p>	<p>90 min.</p>
	<p>3.0Ah BL1830B (197599-5)</p>	<p>22 min.</p>	<p>22 min. Fast Charging</p>	<p>60 min.</p>
	<p>2.0Ah BL1820B (197256-5)</p>	<p>24 min.</p>	<p>24 min. Fast Charging</p>	<p>45 min.</p>
	<p>1.5Ah BL1815N (196235-0)</p>	<p>15 min.</p>	<p>15 min. Fast Charging</p>	<p>30 min.</p>
	<p>1.3Ah BL1815 (194513-2)</p>	<p>15 min.</p>	<p>15 min. Fast Charging</p>	<p>30 min.</p>

	<p>Speed Charger DC10SB (197346-4) Pengecas Pantas 快速充电器</p>	<p>Dual Port Fast Charger DC18RE (198446-3) Pengecas Pantas Dua Port 两端快速充电器</p>	<p>Standard Charger DC10WD (197450-9) Pengecas Standard 标准充电器</p>			<p>Standard Charger DC10WA (194589-9) Pengecas Standard 标准充电器</p>			
	<p>4.0Ah BL1041B (197406-2)</p>	<p>60 min. Fast Charging</p>	<p>130 min.</p>	<p>1.3Ah BL1013 (194550-6) (196066-7)</p>	<p>1.5Ah BL0715 (198000-3)</p>	<p>1.0Ah BL7010 (194355-4)</p>	<p>50 min. BL1013</p>	<p>35 min. BL0715</p>	<p>30 min. BL7010</p>
	<p>2.0Ah BL1021B (197396-9)</p>	<p>30 min. Fast Charging</p>	<p>70 min.</p>	<p>18V G-Battery</p>			<p>Standard Charger DC18WA (195424-4) Pengecas Standard 标准充电器</p>		
<p>1.5Ah BL1016 (197393-5)</p>	<p>22 min. Fast Charging</p>	<p>50 min.</p>	<p>1.5Ah BL1815G (198186-3)</p>	<p>70 min.</p>					

<p>14.4V Ni-MH</p>	<p>12V Ni-MH</p>	<p>9.6V Ni-MH</p>	<p>Standard Charger DC18SD (194534-4)</p>	<p>Automotive Charger DC18SE (194618-8)</p>	<p>12V Ni-CD</p>	<p>9.6V Ni-CD</p>	<p>Standard Charger DC1414 (193865-8)</p>			
<p>3.1Ah BH1433 (193354-3)</p>	<p>3.1Ah BH1233C (193930-3)</p>	<p>3.1Ah BH9033A (193591-9)</p>	<p>70 min.</p>	<p>70 min.</p>	<p>1.9Ah 1222 (192597-4)</p>	<p>—</p>	<p>45 min.</p>			
<p>1.8Ah BH1420 (193351-9)</p>	<p>1.8Ah BH1220C (193928-0)</p>	<p>1.8Ah BH9020 (193631-3)</p>	<p>40 min.</p>	<p>40 min.</p>	<p>1.3Ah PA12 (193981-6)</p>	<p>1.3Ah 1220 (192681-5)</p>	<p>1.3Ah PA09 (193977-7)</p>	<p>1.3Ah 9120 (192638-6)</p>	<p>1.3Ah 9100 (192019-4)</p>	<p>30 min.</p>
<p>14.4V Ni-MH</p>	<p>12V Ni-MH</p>	<p>9.6V Ni-MH</p>	<p>Standard Charger DC1414 (193865-8)</p>	<p>70 min.</p>	<p>9.6V Ni-CD</p>	<p>7.2V Ni-CD</p>	<p>Standard Charger DC1414 (193865-8)</p>			
<p>2.8Ah 1435 (193060-0)</p>	<p>2.8Ah 1235 (193059-5)</p>	<p>2.8Ah 9135 (193058-7)</p>	<p>70 min.</p>	<p>1.3Ah 9000 (191681-2)</p>	<p>—</p>	<p>1.3Ah 7000 (191679-9)</p>	<p>30 min.</p>			

BATTERY INFORMATION

Maklumat Bateri 关于电池的资讯



How to Keep Your Batteries at Their Best

Cara menggunakan prestasi bateri yang terbaik 如何使用才能发挥电池的最佳效能

Note the precautions below for keeping your batteries (Ni-Cd, Ni-MH, Li-ion) at their best to obtain maximum potential cycle life of batteries.

Perhatikan langkah penjagaan bateri berikut untuk memastikan bateri anda (Ni-Cd, Ni-MH, Li-ion) berada pada tahap terbaik untuk jangka hayat bateri berpotensi maksimum.

关于电池 (镍镉、镍氢、锂电池) 的最佳使用方法请参考下面的注意项目。电池将可得到最大的使用寿命。

1

No over-discharge

Stop using a tool and charge the battery when the tool power goes down or its motor speed slows down. Do not use a cordless tool when its power goes down. Otherwise, it will cause an imbalance of battery cells and reduction of battery cycle life.

Elakkan pelepasan berlebihan. Jika alat kuasa anda daya lemah (pengurangan kelajuan putaran motor) semasa penggunaan, berhenti menggunakannya dengan segera dan mengecaskan bateri (bateri dapat diisi semasa suhu turun ke suhu bilik). Dilarang terus menggunakan alat kuasa apabila kekuatannya semakin lemah kerana ketidakseimbangan sel bateri akan mengurangkan jangka hayat bateri. 避免过度放电在使用工具中如果感觉到力道减弱(马达的回转速降低)时, 须马上停止使用且稍后(电池温度降至室温即可充电)进行充电。 严禁工具的力道减弱时还继续的使用。 会因为元件容量的不均而导致电池寿命的短缺。

2

No quick discharge

Avoid overloading during tool operation that causes quick discharge.

Elakkan beban berlebihan semasa operasi alat kuasa yang akan menyebabkan pelepasan cepat. 避免急速放电使用时请注意避免有过负载现象发生。

3

No over-charge

Recharging a fully charged battery is called "Over-charge". This will cause reduction of battery cycle life.

Elakkan pengecasan berlebihan. Mengecas semula bateri yang dicas penuh disebut "Over-charge". Ini akan mengurangkan jangka hayat bateri. 避免过度充电, 充电后满电状态又再次作充电动作。 这称为[过充电], 是导致电池寿命降低的原因。

If a fully charged battery is about to be charged, Makita automatic maintenance function will stop recharging immediately to prevent battery deterioration.

Sekiranya bateri yang penuh dicas semula, fungsi penyelenggaraan automatik akan diaktifkan untuk menghentikan tindakan pengecasan untuk mengelakkan kerosakan bateri. 牧田滑动式电池对于充满电后又再次作充电时, 自动保养机能会启动, 将充电动作停止, 防止电池的劣化产生。

4

Charge your batteries at an ambient temperature from 10°C to 40°C

Do not charge batteries cold from storage at a low ambient temperature below 10°C, or they are damaged. Also batteries are damaged at a high ambient temperature above 40°C, as the deterioration of battery cell materials are hastened by such a high temperature. Therefore, optimum air temperature for charging of batteries is from 10°C to 40°C. When you recharge a battery hot from operation of tool, do not leave it in the tool, but set it on the Makita charger for slide style batteries that will cool down the hot battery fast and efficiently with its forced air cooling system before recharging. This unique system will surely protect batteries from deterioration from heat.

Mengecas bateri yang disimpan pada suhu persekitaran antara 10 °C hingga 40 °C. Pengecasan bateri yang disimpan pada suhu persekitaran rendah (di bawah 10 °C) akan menyebabkan kerosakan bateri. Pengecasan bateri yang disimpan pada suhu persekitaran tinggi (melebihi 40 °C), kemerosotan bahan dalaman bateri akan dipercepat dan menyebabkan kerosakan bateri. Keluarkan bateri yang panas dari alat kuasa selepas penggunaan dan letakkan bateri pada pengecas. Pengecas Makita akan melindungi bateri daripada kerosakan akibat panas.

在10°C以下的低温环境中保管的电池如果进行充电, 将对电池的本身造成伤害。另外, 在40°C以上的高温环境下, 会加速电池内部材料的劣化, 也会对电池的本身造成伤害。在10°C~40°C的温度内充电是最合适的。刚使用完且还有些发热状态的电池, 不要插在电动工具上。需移置到充电器。充电器的冷却装置会很有效率的将电池散热后再进行充电, 如此, 可以防止发热导致电池劣化的情形发生。

5

Keep your batteries away from moisture

High humidity and extreme temperature swings cause dew drop, and it will cause rust and short-circuit.

Elakkan bateri dari wap air. Kelembapan tinggi dan perubahan suhu yang melampau akan menyebabkan karat dan litar pintas. 不要触碰水气, 生锈是短路的原因, 高温, 极端的温度差会导致结露现象产生。

6

Do not exert any significant impact on batteries

String impact on battery will cause internal wire breakage or cracks on battery housing.

Elakkan hentakan ketara yang akan menyebabkan kerosakan wayar dalaman atau keretakan pada penutup bateri. 不要强烈撞击, 外壳的破损, 是内部断线的原因。

Battery Care & Storage

Penjagaan & simpanan bateri 电池的保管方法

Store batteries at an ambient temperature below 35°C. Avoid storing batteries at a high air temperature and humidity

Simpan bateri pada suhu persekitaran di bawah 35°C, elakkan menyimpan bateri pada suhu dan kelembapan udara yang tinggi 将电池存放在低于35°C的环境温度下, 避免将电池存放在空气温度高和湿度高的地方

<p>Storage in fully charged condition</p> <p>Jenis bateri yang mesti disimpan dalam keadaan terisi penuh 须在充满电状态下保管的电池种类</p>	 <p>Li-ion Battery Bateri Li-ion 锂电池</p>	 <p>Ni-MH Battery Bateri Ni-MH 镍氢电池</p>	<p>Storage in fully discharged condition</p> <p>Jenis bateri yang mesti disimpan dalam keadaan habis 须在放电状态下保管的电池种类</p>	 <p>Ni-CD Battery Bateri Ni-CD 镍镉电池</p>
---	--	---	--	---

* Ni-MH batteries have to be charged once a year due to its self-discharging nature.

* Ni-CD batteries have to be fully discharged before storage. After storage for sometimes, ensure Ni-CD batteries are fully charged before use.

Non-Genuine "Counterfeit" Makita Li-Ion Batteries

CAUTION: Makita Corporation notifies tool users of the disadvantages and risks of using non-genuine "Counterfeit" Makita Li-Ion batteries.

Using non-genuine "Counterfeit" Makita batteries will result in:

- Voiding the Makita Warranty for the Makita tool and the charger
- Voiding your country's standards approval of the tool

When using non-genuine "Counterfeit" Makita Li-Ion batteries, there is also a risk of:

- The battery explosion that may result in personal injury and/or property damage
- Possible fire damage to the tool, the battery and/or the charger
- Unknown tool performance

Makita bears no liability for accidents, personal injury or property damage (or damage to batteries, tools or chargers) that occurs as a result of the use of non-genuine "counterfeit" batteries.

Makita only approves the use of genuine parts and accessories with Makita tools. Makita does not approve the use of non-genuine or "counterfeit" batteries which are marketed and sold by third parties for use in Makita Li-Ion cordless tools.

Be sure to use genuine Makita Li-Ion batteries only

Non-Genuine Makita Li-Ion Battery From National Institute of Technology and Evaluation (NITE)



CORDLESS ADVANTAGE

Tanpa Kord 充电式优势



Easy to Use

Mudah digunakan 方便使用

Start-up

Dihidupkan 启动

Engine tools

Alat kuasa enjin 引擎工具



Engine tools need time and tips to start-up
Alat kuasa enjin memerlukan masa untuk dihidupkan
引擎工具需要时间和技巧来启动

Cordless tools

Alat kuasa tanpa kord 充电式工具



Cordless tools start just after inserting battery and switching on
Alat kuasa tanpa kord mudah dihidupkan dengan pemasangan bateri sahaja
安装电池后并开启充电式工具便可开始工作

Constant speed control

Kelajuan tetap 电子恒速控制

Engine tools

Alat kuasa enjin 引擎工具



Engine tools are hard to keep the constant rotation speed under load

Alat kuasa enjin sukar untuk mengekalkan kelajuan putaran berterusan
引擎工具很难在负载下保持恒定的转速

Cordless tools

Alat kuasa tanpa kord 充电式工具



Cordless tools keep rotation speed under load with "Constant speed control" function

Alat kuasa tanpa kord berfungsi "kawalan kelajuan putaran berterusan"
充电式工具保持旋转"恒定负载下的速度"控制功能

Low noise (Noise level comparison)

Bunyi rendah 低噪声

Engine tools

Alat kuasa enjin 引擎工具



Cordless tools

Alat kuasa tanpa kord 充电式工具



Clean & Easy Maintenance

Bersih dan mudah dijaga 清洁和容易保养



Zero emission

Tanpa pelepasan asap 无排气

Engine tools

Alat kuasa enjin 引擎工具



Cordless tools

Alat kuasa tanpa kord 充电式工具



Cordless tools don't generate any exhaust gas
Alat kuasa tanpa kord tidak mengeluarkan gas ekzos
充电式工具不会产生废气

Cost and time reduction

Kurangkan kos dan masa 减少成本和時間

Engine tools

Alat kuasa enjin 引擎工具



It takes time to prepare mixed fuel for engine
Mengambil masa untuk menyediakan bahan api campuran untuk Enjin
需时为发动机准备混合燃料

Cordless tools

Alat kuasa tanpa kord 充电式工具



Just insert battery and ready to use
Pasangkan bateri dan sedia untuk digunakan
只需安装电池即可使用

Easy maintenance

Penyelenggaraan mudah 易于维护

Engine tools

Alat kuasa enjin 引擎工具

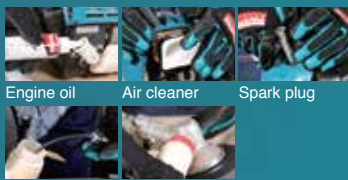

Cordless tools

Alat kuasa tanpa kord 充电式工具



Cordless tools are maintenance - Free unlike engine tools
Alat kuasa tanpa kord bebas dari penyelenggaraan
充电式工具免维护

Long term storage

Penyimpanan jangka panjang 长期存放

Engine tools

Alat kuasa enjin 引擎工具



If you store the tool for a long period, when the fuel remained in the tank It may be a cause of trouble or defect

Alat kuasa enjin mungkin akan rosak sekiranya disimpan lama dengan bahan api dalam tangki
燃油长时间留在油箱可能会造成工具故障

Cordless tools

Alat kuasa tanpa kord 充电式工具



Even if you store the tools for a long period, Just insert battery and ready to use
Walaupun menyimpan dalam jangka masa yang panjang, alat kuasa tanpa kord sedia digunakan dengan pemasangan bateri
充电式工具即使长时间存放, 只需安装电池即可使用



Purpose-built Brushless Motors

Motor tanpa berus 无碳刷马达

Makita-built Brushless Motor eliminates carbon brushes, enabling the motor to run cooler and more efficiently for longer life. The electronically controlled Brushless Motor efficiently uses energy to match torque and RPM to the changing demands of the application

Motor tanpa berus yang dibuat oleh Makita menghapuskan berus karbon, membolehkan motor berjalan lebih sejuk, lebih cekap dan lebih tahan lama. Motor tanpa berus yang dikawal secara elektronik dengan cekap menggunakan tenaga untuk menyesuaikan tork dan RPM kepada perubahan permintaan aplikasi
Makita制造的无碳刷马达消除了碳刷, 使马达更冷却的运作, 更有效, 更长使用寿命。电子控制的无碳刷马达有效地利用能量将扭矩和RPM以配合不断变化的需求



XPT

EXTREME PROTECTION TECHNOLOGY

Teknologi Perlindungan Ekstrim
防尘防水滴技术

Enhanced dust and drip-resistant performance of the tools

Prestasi tahan debu dan tahan titisan air
提高工具的防尘与防水滴性能, 令工具更耐用



Dust-resistant

Tahan debu 防尘



Drip-resistant

Tahan titisan air 防水滴

The pictures do not mean to ensure the products are perfectly durable against dust and water, though they are designed to prevent dust and water ingress.
Walaupun XPT direka untuk tahan titisan air dan tahan debu, ia tidak menjamin berlakunya kerosakan alat kuasa yang disebabkan oleh air atau debu
注意: 照片为示意图。
XPT设计虽然可以抑制水或粉尘所带来的影响, 但不能保证因为水或粉尘所导致的故障发生。XPT设计概念主要是在恶劣环境之下也可正常工作。

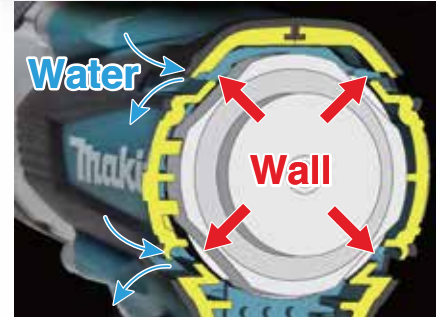

Because the walls are installed inside the vents, water and dust cannot enter easily.
Terdapat komponen elektronik yang dilipisi untuk menyekat kemasukan titisan debu dan air.
有包覆电子零件阻隔粉尘、水滴入侵。

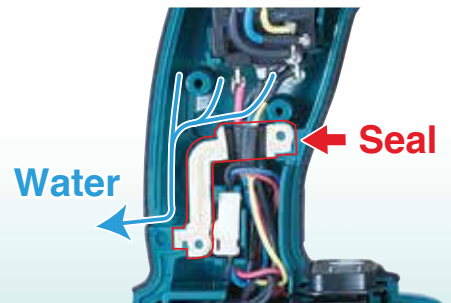

Moreover, even if water enters, it is discharged outside.
Sekiranya air masuk, ia dibuang ke luar.
若有水入侵时, 也被排出外部。

AWS

Auto - start Wireless System

Sistem permulaan wayarles automatik
无线自动启动系统

Connects to Compatible Vacuum Cleaners with Bluetooth

Sambungan tanpa wayar dengan pembersih vakum yang serasi dengan Bluetooth 通过蓝牙连接到兼容的吸尘器



WUT01 wireless unit

Enables wireless connection of Makita AWS™ capable tools with AWS™ Vacuum Cleaners

Untuk sambungan tanpa wayar alat kuasa AWS™ Makita dengan pembersih vakum AWS™
Makita AWS™ 工具与AWS™ 吸尘器无线连接



Part No. 199393-1

WUT02 wireless unit adapter

Enables wireless connection of Makita AWS™ capable tools with most AC vacuum cleaner with auto start/ stop functions

Sambungan tanpa wayar alat kuasa AWS™ Makita dengan pembersih vakum AC yang berfungsi permulaan/ berhenti automatik
无线连接具有Makita AWS™ 功能的电动工具与具有自动启动/停止功能的AC吸尘器



Part No. 199809-6

AVT

ANTI VIBRATION TECHNOLOGY

Teknologi Anti Getaran
防振技术



- Vibration absorbing housing
- Active dynamic vibration absorber
- Damper spring

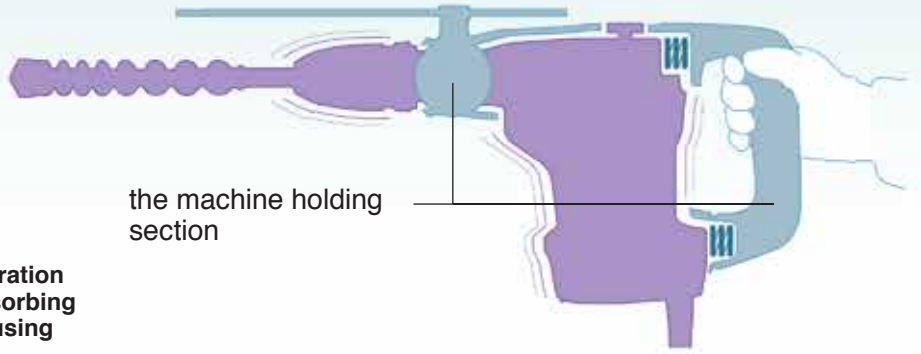

the machine holding section

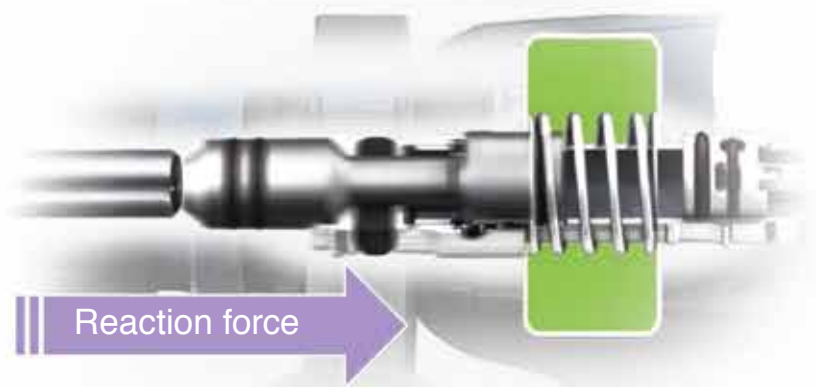
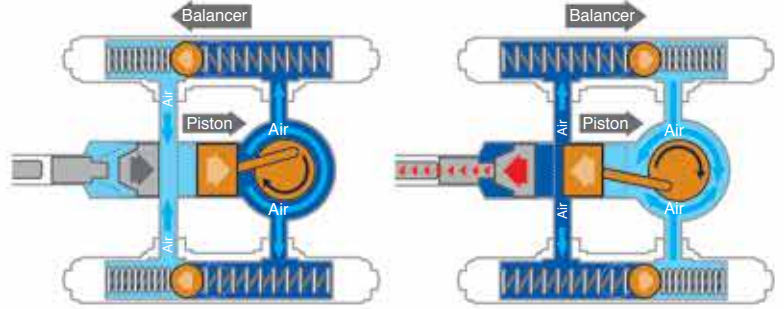

SOFT NO LOAD

Getaran rendah tanpa beban
无负载时低振动

During no-load



Suppression of motor speed

Penindasan kelajuan motor 电机转速的抑制

- reduces vibration of tool body when idling, accordingly decreases the amount of vibration to operator's hands during a day's operation
mengurangkan getaran badan alat ketika melahu, dengan itu mengurangkan jumlah getaran ke tangan pengendali semasa operasi sehari 减少空转时工具主体的振动, 从而减少一天操作中操作者手部的振动量
- minimizes deflection of bit tip from aiming point when starting chipping
meminimumkan pesongan bit tip dari titik sasaran apabila memulakan kerepotan 开始切屑时, 将刀尖从瞄准点的偏移减至最小

During no-load

Under load

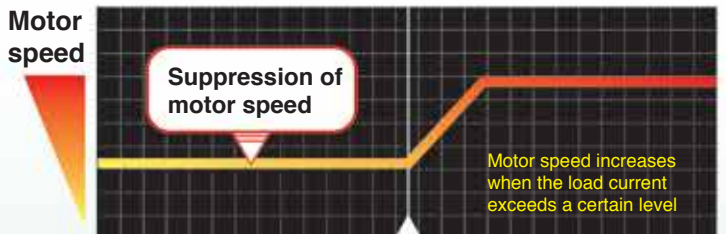

when starting chipping

Equipped with automatic speed control

Dilengkapi dengan kawalan laju automatik 设置自动速度控制功能

ADT
Automatic Torque Drive Technology
Teknologi Torq Automatik
自动扭力驱动科技

Automatically changes the cutting speed according to load conditions for an optimum operation
Fungsi pertukaran kelajuan automatik 自动变速功能

- On light duty: high-speed rotation mode
- On heavy duty: high torque mode
- Pada tugas ringan: mod putaran berkelajuan tinggi
- Pada tugas berat: mod torq tinggi
- 轻载: 高速旋转模式
- 重载: 高扭矩模式

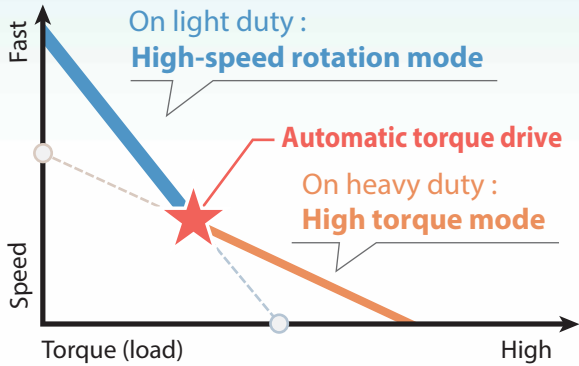

Smart function to minimize the danger of kick-back

Fungsi pintar untuk mengurangkan risiko kick-back 智慧型功能可减少反冲之危

AFT
Active Feedback Sensing Technology
Teknologi Sensor Maklum Balas Automatik
自动回馈感应科技

Shuts down the tool to protect the user, if the rotation speed suddenly slows down

Jika kelajuan putaran tiba-tiba dikurangkan, alat akan dimatikan secara automatik untuk melindungi pengguna

若旋转速度突然降低, 工具将自动关闭以保护使用者

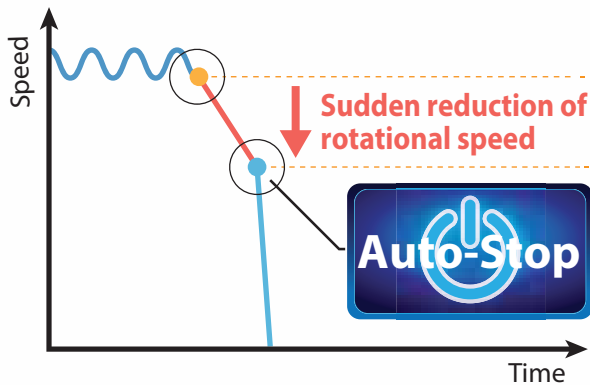

Electric Brake System
Sistem Brek Elektrik 电子自动刹车系统

Electric brake

Brek elektrik 电子自动刹车

Electric brake is activated after the tool is switched off

Brek elektrik diaktifkan selepas alat dimatikan
电子自动刹车在工具关闭后被启动

Large switch lever

Tuas suis yang besar 大开关杆

with lock-off function (without lock-on function)

Lock-off function prevents the switch lever from being accidentally pulled dengan fungsi mengunci
menghalang tuas suis daripada ditarik secara tidak sengaja
锁定功能可防止开关杆被意外拉动

Anti-restart function

Fungsi anti-restart 防止意外重启功能

The motor does not start up if battery is inserted when the switch slid to "on".

Selepas memuatkan bateri, motor tidak bermula jika suis ditetapkan ke kedudukan "ON"
装入电池后, 若开关关于「开启」位置时, 马达不会启动

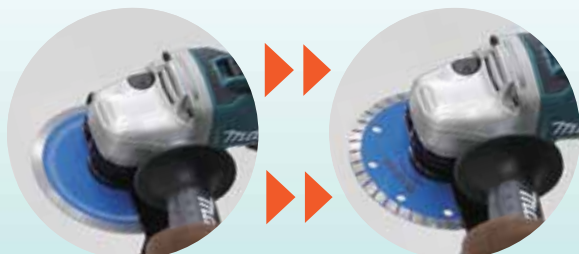

Electric brake is activated after the tool is switched off
Brek elektrik diaktifkan selepas alat dimatikan
电子自动刹车在工具关闭后被启动





TO SUPPRESS VIBRATION TO OPERATOR

Menahan Getaran 在操作时能抑止震动

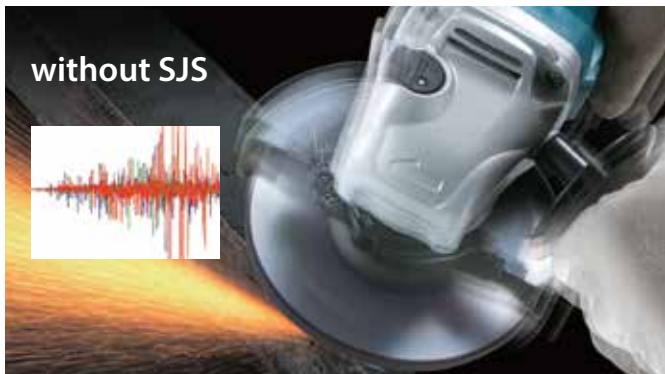

Structure of Super Joint System II

Struktur SJS generasi kedua 第二代 SJS 的结构

Leaf spring absorbs vibration and relieves shock during operation.

Leaf spring menyerap getaran dan mengurangkan kesan hentaman semasa operasi 在运行过程中，弹簧片吸收振动并减轻冲击



Absorption mechanism of vibration

Mekanisme penyerapan getaran 振动的吸收机能

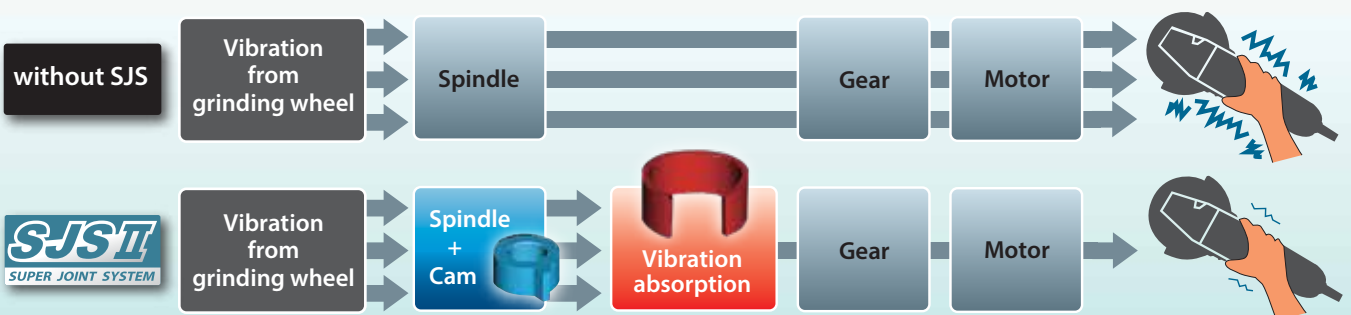

Automatic Self-cleaning Filtration System achieved by two filter units

Sistem Penapis Penyucian Automatik 自动清洗过滤系统

Constantly high suction power throughout operation because dust is removed from Prefilters every 10 seconds during operation

Kuasa penyedut yang berterusan sepanjang operasi kerana habuk dikeluarkan dari penapis setiap 10 saat semasa operasi

在整个运行过程中吸力保持在较高的水平，因为在运行过程中，每10秒就会从过滤器中除去灰尘



Automatic self-cleaning filter (VC1310L, VC2510L, VC3210L)

Sistem Penapis Penyucian Automatik 自动清洗过滤系统

obtained by Triple filter structure composed of: Powder filter + Damper + Prefilter

Kuasa penyedutan yang berterusan sepanjang operasi kerana habuk dikeluarkan dari Prefilters setiap 10 saat semasa operasi

由三重过滤器结构得到：粉末过滤器+阻尼器+预过滤器



When the power is switched on, Prefilter collapses into itself to compress Damper, and fits closely over Damper and Powder filter.

Apabila kuasa dihidupkan, Prefilter runtuh ke dalamnya untuk memampatkan Damper, dan sesuai dengan penapis Damper dan Serbuk.
当接通电源时，Prefilter会自行折叠以压缩阻尼器，并紧密贴合阻尼器和粉末过滤器。

When the power is switched off, Damper expands back to its original size and shakes off dust from Prefilter automatically with its expanding power.

Apabila kuasa dimatikan, Damper mengembang kembali ke saiz asalnya dan menggelakkan habuk dari Prefilter secara automatik dengan kuasa yang berkembang.
当电源关闭时，阻尼器膨胀回到其原始尺寸，并通过扩展的功率自动将Prefilter的灰尘抖落。



DEEP CUTTING

Pemotongan dalam 深层切割

DXT

Deep and Exact Cutting Technology

Teknologi Pemotongan Ketepatan Dalam
深层精准切割技术

3-Stage reduction gear unit and Movable rear blade guard provide larger capacities of cutting Crown molding and Baseboard (Skirt board)

Peranti gear pengurangan tiga peringkat dan tutup belakang bilah gergaji boleh alih untuk pemotongan mudah diagonal garisan siling dan garis sudut (panel dinding) 三级减速齿轮装置及活动的后锯片护罩, 方便斜切天花板线和墙角线(护壁板)

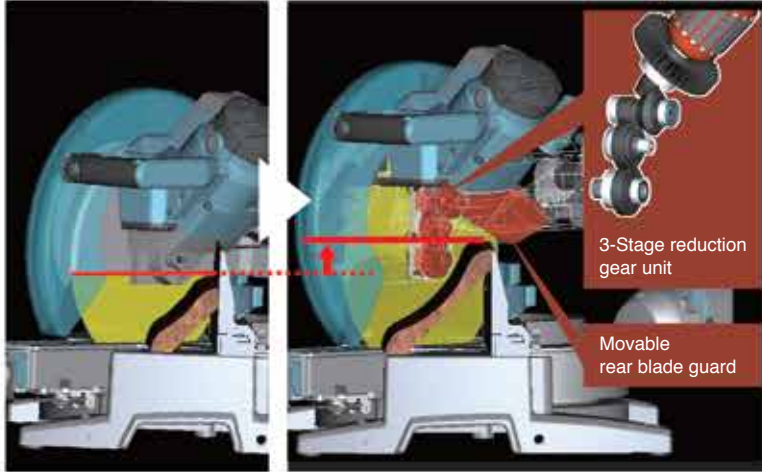

Capable of diagonal cutting up to **203mm (8")** crown molding

Capable of vertical cutting up to **165mm (6-1/2")** baseboard (skirt board)

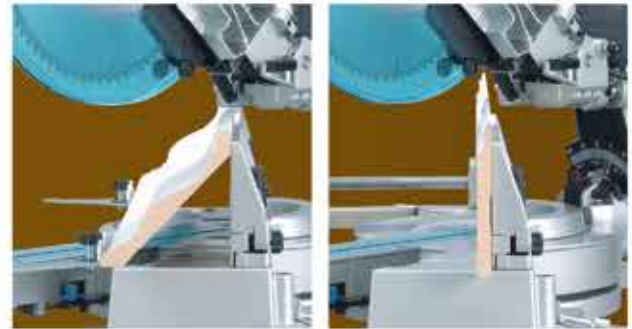

EXACT CUTTING

Pemotongan ketepatan 精准切割

Double sliding mechanism

Teknologi pemotongan ketepatan dalam 双重滑动结构

Makita advantages obtained by using 4 short steel poles instead of 2 long poles are;

- Vibration-free, precise and exact cutting
- Compact tool design for jobsite portability

Gantikan 4 paip keluli panjang dengan 4 paip keluli pendek, supaya produk Makita mempunyai kelebihan berikut

- Bebas getaran, pemotongan tepat
- Reka bentuk alat padat untuk kemudahan medan

以4支短钢管取代2支长钢管, 令牧田产品有以下优势之处

- 无振动, 精确切割
- 紧凑的工具设计可实现现场便携性

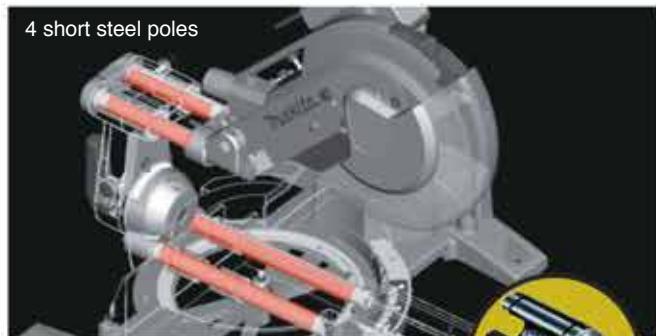

4 short steel poles

6 linear ball bearings are used to support the 4 poles for smooth and precise sliding cut.

Double sliding guide fence

Teknologi pemotongan ketepatan dalam 双重滑动引导栅

The upper and the lower sections slide independently for added convenience; each upper fence slides outwards for bevel cut, and each lower fence slide inwards to securely hold small workpiece for precise and exact cutting

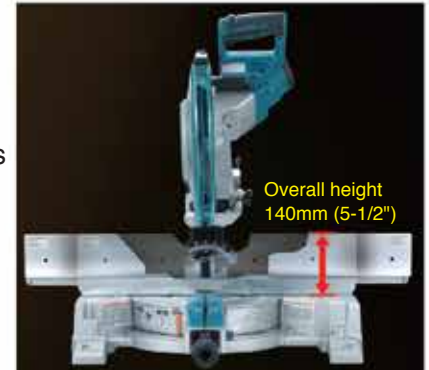

Overall height 140mm (5-1/2")

Bahagian atas dan bawah meluncur secara berasingan untuk kemudahan tambahan, grid panduan atas boleh meluncur ke luar pada sudut serong untuk dipotong, dan grid panduan bawah dapat meluncur ke dalam untuk memegang bahan-bahan kecil untuk memotong tepat

上下部分独立滑动以增加便利; 上部引导栅能向外滑动斜角切割, 而下部引导栅能向内滑动以牢牢地固定小材料, 以进行精确的切割

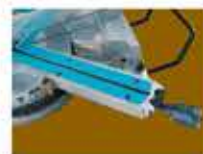

Quick and accurate miter angle lock

Kunci sudut miter yang cepat dan tepat
快速准确的斜接角度锁定

- Miter angle can be locked/unlocked simply by turning the knob 90 degrees.
- With positive stops at 0, 15, 22.5, 31.6, 45 degrees



LS003G 40V max

LS004G 40V max

LS002G 40V max

DLS211

DLS111

DLS600 18V LITHIUM ION

LS1019L

LS1219L

MAKPAC POWER SOURCE KIT

Set Bateri MAKPAC | MAKPAC锂电池套装

XGT 40Vmax
18V LITHIUM-ION







- 1 Makpac Connector Box Type 1 (821549-5)
Kotak Sambungan Makpac 工具连接箱
- 1x Adapter ADP10 (191C11-5)
Penyesuai 适配器
- 1x Fast Charger DC40RA (191E08-6)
Pengecas Pantas 快速充电器
- 2x 2.5Ah Battery BL4025 (191B36-3)
1x 6.0Ah Battery BL1860B (197422-4)
Bateri 锂电池

BASIC
40Vmax 2.5Ah + 18V 6.0Ah

PSKG1
(191T63-8)

XGT 40Vmax
18V LITHIUM-ION





- 1 Makpac Connector Box Type 1 (821549-5)
Kotak Sambungan Makpac 工具连接箱
- 1x Fast Charger DC40RA (191E08-6)
Pengecas Pantas 快速充电器
- 2x 2.5Ah Battery BL4025 (191B36-3)
Bateri 锂电池

POWER
40Vmax 2.5Ah

MKP1G001
(191J86-6)

XGT 40Vmax
18V LITHIUM-ION



- 1x Fast Charger DC40RA (191E08-6)
Pengecas Pantas 快速充电器
- 1x 4.0Ah Battery BL4040 (191B26-6)
Bateri 锂电池

BASIC
40Vmax 4.0Ah

PSKG0
(191J70-1)

XGT 40Vmax
18V LITHIUM-ION





- 1 Makpac Connector Box Type 1 (821549-5)
Kotak Sambungan Makpac 工具连接箱
- 1x Fast Charger DC40RA (191E08-6)
Pengecas Pantas 快速充电器
- 2x 4.0Ah Battery BL4040 (191B26-6)
Bateri 锂电池

POWER
40Vmax 4.0Ah

MKP1G002
(191K02-4)

XGT 40Vmax
18V LITHIUM-ION





- 1 Makpac Connector Box Type 3 (821551-8)
Kotak Sambungan Makpac 工具连接箱
- 1x Two Port Multi Fast Charger DC40RB (191N14-5)
Pengecas Pantas Dua Port 两端快速充电器
- 2x 5.0Ah Battery BL4050F (191L47-8)
Bateri 锂电池

ADVANCED
40Vmax 5.0Ah

PSKG3
(191U20-2)

XGT 40Vmax
18V LITHIUM-ION





- 1 Makpac Connector Box Type 3 (821551-8)
Kotak Sambungan Makpac 工具连接箱
- 1x Two Port Multi Fast Charger DC40RB (191N14-5)
Pengecas Pantas Dua Port 两端快速充电器
- 4x 5.0Ah Battery BL4050F (191L47-8)
Bateri 锂电池

ULTIMATE
40Vmax 5.0Ah

PSKG3
(191U48-0)

18V LITHIUM-ION
18V Lithium-ion | 18V锂离子





- 1 Makpac Connector Box Type 1 (821549-5)
Kotak Sambungan Makpac 工具连接箱
- 1x Rapid Charger DC18RC (195586-8)
Pengecas Pantas 快速充电器
- 1x 3.0Ah Battery BL1830B (197599-5)
Bateri 锂电池

BASIC
18V 3.0Ah

MKP1RF181
(197973-7)

18V LITHIUM-ION
18V Lithium-ion | 18V锂离子





- 1 Makpac Connector Box Type 1 (821549-5)
Kotak Sambungan Makpac 工具连接箱
- 1x Rapid Charger DC18RC (195586-8)
Pengecas Pantas 快速充电器
- 2x 3.0Ah Battery BL1830B (197599-5)
Bateri 锂电池

POWER
18V 3.0Ah

MKP1RF182
(197974-5)

18V LITHIUM-ION
18V Lithium-ion | 18V锂离子





- 1 Makpac Connector Box Type 1 (821549-5)
Kotak Sambungan Makpac 工具连接箱
- 1x Rapid Charger DC18RC (195586-8)
Pengecas Pantas 快速充电器
- 2x 4.0Ah Battery BL1840B (197265-4)
Bateri 锂电池

POWER
18V 4.0Ah

MKP1RM182
(191L71-1)

18V LITHIUM-ION
18V Lithium-ion | 18V锂离子





- 1 Makpac Connector Box Type 1 (821549-5)
Kotak Sambungan Makpac 工具连接箱
- 1x Rapid Charger DC18RC (195586-8)
Pengecas Pantas 快速充电器
- 1x 5.0Ah Battery BL1850B (197282-4)
Bateri 锂电池

BASIC
18V 5.0Ah

MKP1RT181
(197801-6)

18V LITHIUM-ION
18V Lithium-ion | 18V锂离子





- 1 Makpac Connector Box Type 1 (821549-5)
Kotak Sambungan Makpac 工具连接箱
- 1x Rapid Charger DC18RC (195586-8)
Pengecas Pantas 快速充电器
- 2x 5.0Ah Battery BL1850B (197282-4)
Bateri 锂电池

POWER
18V 5.0Ah

MKP1RT182
(197803-2)

18V LITHIUM-ION
18V Lithium-ion | 18V锂离子





- 1 Makpac Connector Box Type 3 (821551-8)
Kotak Sambungan Makpac 工具连接箱
- 1x Two Port Multi Rapid Charger DC18RD (196934-4)
Pengecas Pantas Dua Port 两端快速充电器
- 2x 5.0Ah Battery BL1850B (197282-4)
Bateri 锂电池

ADVANCED
18V 5.0Ah

MKP3PT182
(198182-1)

18V LITHIUM-ION
18V Lithium-ion | 18V锂离子





- 1 Makpac Connector Box Type 3 (821551-8)
Kotak Sambungan Makpac 工具连接箱
- 1x Two Port Multi Rapid Charger DC18RD (196934-4)
Pengecas Pantas Dua Port 两端快速充电器
- 4x 5.0Ah Battery BL1850B (197282-4)
Bateri 锂电池

ULTIMATE
18V 5.0Ah

MKP3PT184
(197627-6)

18V LITHIUM-ION
18V Lithium-ion | 18V锂离子





- 1 Makpac Connector Box Type 1 (821549-5)
Kotak Sambungan Makpac 工具连接箱
- 1x Rapid Charger DC18RC (195586-8)
Pengecas Pantas 快速充电器
- 2x 6.0Ah Battery BL1860B (197422-4)
Bateri 锂电池

ADVANCED
18V 6.0Ah

MKP1RG182
(198119-8)

18V LITHIUM-ION
18V Lithium-ion | 18V锂离子





- 1 Makpac Connector Box Type 3 (821551-8)
Kotak Sambungan Makpac 工具连接箱
- 1x Two Port Multi Rapid Charger DC18RD (196934-4)
Pengecas Pantas Dua Port 两端快速充电器
- 4x 6.0Ah Battery BL1860B (197422-4)
Bateri 锂电池

ULTIMATE
18V 6.0Ah

MKP3PG184
(198095-6)

12Vmax LITHIUM-ION
12V Lithium-ion | 12V锂离子





- 1 Makpac Connector Box Type 1 (821549-5)
Kotak Sambungan Makpac 工具连接箱
- 1x Speed Charger DC10SB (197346-4)
Pengecas Pantas 快速充电器
- 2x 1.5Ah Battery BL1016 (197393-5)
Bateri 锂电池

BASIC
12Vmax 1.5Ah

MKP1SY122
(197654-3)

12Vmax LITHIUM-ION
12V Lithium-ion | 12V锂离子





- 1 Makpac Connector Box Type 1 (821549-5)
Kotak Sambungan Makpac 工具连接箱
- 1x Speed Charger DC10SB (197346-4)
Pengecas Pantas 快速充电器
- 2x 2.0Ah Battery BL1021B (197396-9)
Bateri 锂电池

POWER
12Vmax 2.0Ah

MKP1SA122
(197664-0)

12Vmax LITHIUM-ION
12V Lithium-ion | 12V锂离子





- 1 Makpac Connector Box Type 1 (821549-5)
Kotak Sambungan Makpac 工具连接箱
- 1x Speed Charger DC10SB (197346-4)
Pengecas Pantas 快速充电器
- 2x 4.0Ah Battery BL1041B (197406-2)
Bateri 锂电池

ULTIMATE
12Vmax 4.0Ah

MKP1SM122
(197640-4)

Comfortable for Long Hours Operation

Selesa untuk operasi masa panjang 舒适的长时间操作

Portable Power Pack

Bekalan kuasa mudah alih 背式电池扩充座

PDC1200



Capacity Kapasiti 能力	33.5Ah
Energy Capacity Keupayaan Tenaga 能量容量	1,206Wh
Power Supply Cord Kord Bekalan Kuasa 电源线	Battery Side: 1.1 m (3.6 ft) Adapter Side: 0.6 m (2.0 ft)

ENERGY CAPACITY COMPARISON

PDC1200

**1 : 22
Ratio**

18V 3.0Ah Battery

IPX4 Water Resistance

*Equipped with built-in battery cells

Quickly removable harness can be attached/removed from the main unit with a single action

Tali sandang bahu cepai dilepaskan, ia boleh dipasang atau dikeluarkan dari unit utama dengan hanya satu operasi

快速拆卸式背带, 只需一次操作即可将其安装在主机上或从主机上卸下

Cord length 1.1m
Panjang kord 电源线长度

Reflectors keep operator visible from a distance even in the dark
Reflektor meningkatkan keselamatan kerja malam
提高夜间作业安全性的反射材料

Charger DC4001

- Equipped with a fan to cool down the charging circuit board
- Removable AC inlet plug

Pengecap DC4001 dilengkapi dengan kipas untuk menyejukkan papan litar pengecasan dan soket kuasa AC yang boleh ditanggalkan

充电器 DC4001 配备风扇冷却充电电路板, 可拆卸交流电源插座

PDC1200A01 included

- 18Vx2 Adapter (Part No. 191J51-5)
- DC4001 Battery Charger Set (Part No. 191L01-2)
- Harness Assembly (127668-8)

Optional for PDC1200 & PDC01

40Vmax Adapter Set (191N62-4)

*Equipped with built-in battery cells

Portable Power Pack

Bekalan kuasa mudah alih 背式电池扩充座

PDC01



Capacity Kapasiti 能力	18V x2 : 12 Ah (with BL1860B x4) 18V : 24 Ah (with BL1860B x4)
Energy Capacity Keupayaan Tenaga 能量容量	432Wh (BL1860Bx4)
Power Supply Cord Kord Bekalan Kuasa 电源线	1.7 m (5.6 ft)

TWO VARIATIONS

1 PDC01 (191A62-6) included

- 18V Adapter (Part No. 191J50-7)
- 18Vx2 Adapter (Part No. 191J51-5)
- Harness Assembly

*Without Battery

2 PDC01 (191A67-6) included

- 18Vx2 Adapter (Part No. 191J51-5)
- Harness Assembly

*Without Battery

IPX4 Water Resistance

Battery cover Protection from water and dust
Penutup bateri untuk perlindungan daripada air dan habuk
防水防尘电池盖

Comfortable, adjustable backpack harness
Tali sandang bahu yang selesa dan boleh laras
舒适可调节的背带

Lightweight Ringan 轻量

7kg
with 4x BL1850B 5.0Ah Battery

Cord length 1.7m
Panjang kord 电源线长度

Fuel gauge for each battery indicates the battery status by two green lights
Penunjuk tahap bateri menunjukkan status bateri dengan dua lampu hijau
每个电池的电量计, 通过两个绿色指示灯指示电池状态

Main power switch With auto-off function
Suis kuasa utama dengan fungsi auto-off 主电源开关具有自动关机功能

Battery Adapter

BAP182 (197581-4)

Compatible Batteries	18V : 1.5Ah to 6.0Ah
----------------------	----------------------

*Without Charger & Batteries

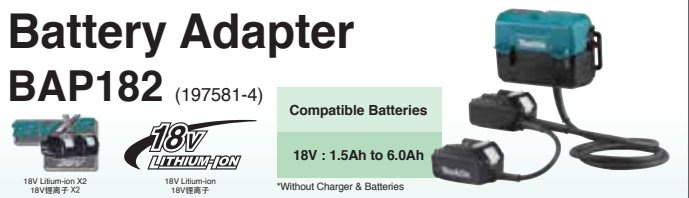

Battery Adapter

BAP18C (191M50-5)

Compatible Batteries	18V : 1.5Ah to 6.0Ah
----------------------	----------------------

*Without Charger & Batteries



Convenience for every OCCASION

Sesuai Untuk Pelbagai Kegunaan/ 适用于任何场合

Heat-resistant Temperature
0 ~ 60°c
Suhu tahan haba 0 ~ 60°c
保冷度 0 ~ 60°c

Maintaining COOL Temperature
Mengekalkan suhu sejuk
冷藏专用

MAKPAC Cool Box

Kotak Sejuk MAKPAC/ 层叠式冷藏箱

20mm thickness formed polystyrene, sealing strips are placed around the mating surface of lid and box

Dibuat dari ketebalan 20mm polistirena dan dipasang dengan jalur pengedap di sekeliling permukaan penutup dan kotak
箱体壁厚为20mm, 盖子和箱子的连接处配备密封条



11L

500mL x 10 | 2L x 2

(Type 3)

Part No. **198254-2**

- **Dimensions**
Dimensi | 体积 (L x W x H)
295 x 395 x 210mm (11-5/8" x 15-1/2" x 8-1/4")
- **Net weight**
Berat bersih | 净重
2.9kg (6.3lbs)



- Both type can be equipped with a shoulder strap
Kedua-dua jenis Makpac boleh dipasang dengan tali pemegang bahu
两种型号皆可配备肩带



MAKPAC BOX

TYPE 1 while stock last
Part No. 821549-5 (1pcs)
Part No. 191K59-5 (6pcs)

TYPE 2 while stock last
Part No. 821550-0 (1pcs)
Part No. 191K60-0 (4pcs)

TYPE 3 while stock last
Part No. 821551-8 (1pcs)
Part No. 191K61-8 (3pcs)

TYPE 4 while stock last
Part No. 821552-6 (1pcs)
Part No. 191K62-6 (2pcs)



18L

500mL x 20 | 2L x 4

(Type 4)

Part No. **198253-4**

- **Dimensions**
Dimensi | 体积 (L x W x H)
295 x 395 x 315mm (11-5/8" x 15-1/2" x 12-3/8")
- **Net weight**
Berat bersih | 净重
3.7kg (8.1lbs)



Part No. **TR0000002**

- Able to stack on MAKPAC trolley for easy loading (option)

Boleh ditambah dan disambung atas troli Makpac untuk memudahkan kerja pengalihan kotak Makpac (pilihan)
Makpac工具箱可以添加并连接到拖运车, 以方便搬运 (选择性)



Come with Shoulder belt
Dilengkapkan dengan tali pemegang bahu | 配备背负肩带

CORDLESS COMBO KIT

CORDLESS COMBO KIT DLX2248PT1

- 1x DVC260Z
**Cordless Backpack
Vacuum Cleaner**
Pembersih Vakum Beg Galas Tanpa Kord
充电式背负吸尘机
- 2x 5.0Ah Battery (BL1850B)
Bateri 5.0Ah (BL1850B)
5.0Ah 电池 (BL1850B)



- 2 1x DCL181F Cordless Cleaner
Pembersih Vakum Tanpa Kord
充电式便携吸尘机
- 1x 5.0Ah Battery (BL1850B)
Bateri 5.0Ah (BL1850B)
5.0Ah 电池 (BL1850B)



- 3 1x Two Port Multi
Rapid Charger (DC18RD)
Pengecas Pantas Dua Port (DC18RD)
两端快速充电器 (DC18RD)



- 4 1x Makita Tool Bag
Beg Alat Makita
Makita 工具袋

CORDLESS COMBO KIT DLX3131TX2

- 1x DHR242 24mm (15/16")
Cordless Combination Hammer
Tukul Kombinasi Tanpa Kord 充电式冲击电钻电锤
- 1x 5.0Ah Battery (BL1850B)
Bateri 5.0Ah (BL1850B) 5.0Ah 电池 (BL1850B)



- 2 1x DGA404 100mm (4")
Cordless Angle Grinder
Pengisar Sudut Tanpa Kord 角向磨光机
- 1x 5.0Ah Battery (BL1850B)
Bateri 5.0Ah (BL1850B) 5.0Ah 电池 (BL1850B)
- 1x Depressed Centre Wheel (A-80852)
Cakera Abrasif 磨片



- 4 1x Two Port Multi
Rapid Charger (DC18RD)
Pengecas Pantas Dua Port (DC18RD)
两端快速充电器 (DC18RD)



- 5 1x Makita Tool Bag (831271-6)
Beg Alat Makita
Makita 工具袋

CORDLESS COMBO KIT DLX2218X

- 1x Rapid Charger (DC18RC)
Pengecas Pantas (DC18RC)
快速充电器 (DC18RC)



- 2 1x DHR165 16mm (5/8")
Cordless Rotary Hammer
Tukul Berputar Tanpa Kord 充电式电锤
- 1x 3.0Ah Battery (BL1830B)
Bateri 3.0Ah (BL1830B) 3.0Ah 电池 (BL1830B)



- 3 1x DTW190 12.7mm (1/2")
Cordless Impact Wrench
Perengkuh Impak Tanpa Kord
充电式冲击套筒扳手
- 1x 3.0Ah Battery (BL1830B)
Bateri 3.0Ah (BL1830B)
3.0Ah 电池 (BL1830B)



- 4 1x Makita Aluminium
Suitcase
Beg Bimbit Aluminium Makita
Makita 铝合金工具箱

CORDLESS COMBO KIT DLX2220

WHILE STOCK LAST
Sementara stok masih ada 售完即止

- 1x Rapid Charger (DC18RC)
Pengecas Pantas (DC18RC)
快速充电器 (DC18RC)



- 2 1x DTD155 Cordless
Impact Driver
Pemutar Skru Impak Tanpa Kord
充电式冲击螺丝起子机
- 1x 3.0Ah Battery (BL1830B)
Bateri 3.0Ah (BL1830B)
3.0Ah 电池 (BL1830B)



- 3 1x DDF483 13mm (1/2")
Cordless Driver Drill
Gerudi Pemutar Skru Tanpa Kord
充电式螺丝起子电钻
- 1x 3.0Ah Battery (BL1830B)
Bateri 3.0Ah (BL1830B)
3.0Ah 电池 (BL1830B)



- 4 1x Makita Tool Bag
Beg Alat Makita
Makita 工具袋

**CORDLESS COMBO KIT
DLX2424JX1**



18V Lithium-Ion | 18V锂离子



Motor tanpa berus 无碳刷马达
EXTREME PROTECTION TECHNOLOGY
Teknologi Perlindungan Ekstrem
防止防水溅技术



1x Rapid Charger (DC18RC)
Pengecas Pantas (DC18RC)
快速充电器 (DC18RC)

2x DMP180
Cordless Inflator
Inflator Tanpa Kord 充电式打气机
1x 5.0Ah Battery (BL1850B)
Bateri 5.0Ah (BL1850B)
5.0Ah 电池 (BL1850B)



3x DTW300
Cordless Impact Wrench
Perengkuh Impak Tanpa Kord 充电式冲击套筒扳手
1x 5.0Ah Battery (BL1850B)
Bateri 5.0Ah (BL1850B) 5.0Ah 电池 (BL1850B)



4x Makpac Connector Box
Kotak Sambungan Makpac 工具连接箱

**CORDLESS COMBO KIT
DLX2417JX1**



18V Lithium-Ion | 18V锂离子



Motor tanpa berus 无碳刷马达
EXTREME PROTECTION TECHNOLOGY
Teknologi Perlindungan Ekstrem
防止防水溅技术



1x Rapid Charger (DC18RC)
Pengecas Pantas (DC18RC)
快速充电器 (DC18RC)

2x DHP484
Cordless Hammer Driver Drill
Tukul Pemutar Skru Bergerudi 冲击螺丝起子电钻
1x 3.0Ah Battery (BL1830B)
Bateri 3.0Ah (BL1830B)
3.0Ah 电池 (BL1830B)



3x DTD156
Cordless Impact Driver
Pemutar Skru Impak 冲击螺丝起子机
1x 3.0Ah Battery (BL1830B)
Bateri 3.0Ah (BL1830B) 3.0Ah 电池 (BL1830B)



4x 1x Double Ended Twist
Torsion Screw Bit
Skrus Kilasan Pintal Dua Mata
双头扭曲扭力螺丝批头
1x (+)(-) Bit
Mata Skru 螺丝批头



5x Makpac Connector Box
Kotak Sambungan Makpac 工具连接箱

**CORDLESS COMBO KIT
DLX2414JX2**



18V Lithium-Ion | 18V锂离子



Motor tanpa berus 无碳刷马达
EXTREME PROTECTION TECHNOLOGY
Teknologi Perlindungan Ekstrem
防止防水溅技术



1x Rapid Charger (DC18RC)
Pengecas Pantas (DC18RC)
快速充电器 (DC18RC)

2x DTD157
Cordless Impact Driver
Pemutar Skru Impak 冲击螺丝起子机
1x 2.0Ah Battery (BL1820B)
Bateri 2.0Ah (BL1820B)
2.0Ah 电池 (BL1820B)



3x DHP487
Cordless Hammer Driver Drill
Tukul Pemutar Skru Bergerudi 冲击螺丝起子电钻
1x 2.0Ah Battery (BL1820B)
Bateri 2.0Ah (BL1820B) 2.0Ah 电池 (BL1820B)



4x 1x Double Ended Twist
Torsion Screw Bit
Skrus Kilasan Pintal Dua Mata
双头扭曲扭力螺丝批头
1x (+)(-) Bit
Mata Skru 螺丝批头



5x Makpac Connector Box
Kotak Sambungan Makpac 工具连接箱

**CORDLESS COMBO KIT
DLX2423JX2**



18V Lithium-Ion | 18V锂离子



Motor tanpa berus 无碳刷马达
EXTREME PROTECTION TECHNOLOGY
Teknologi Perlindungan Ekstrem
防止防水溅技术



1x Rapid Charger (DC18RC)
Pengecas Pantas (DC18RC)
快速充电器 (DC18RC)

2x DTD157
Cordless Impact Driver
Pemutar Skru Impak 冲击螺丝起子机
1x 2.0Ah Battery (BL1820B)
Bateri 2.0Ah (BL1820B)
2.0Ah 电池 (BL1820B)



3x DDF487
Cordless Driver Drill
Gerudi Pemutar Skru 螺丝起子电钻
1x 2.0Ah Battery (BL1820B)
Bateri 2.0Ah (BL1820B) 2.0Ah 电池 (BL1820B)



4x 1x Double Ended Twist
Torsion Screw Bit
Skrus Kilasan Pintal Dua Mata
双头扭曲扭力螺丝批头
1x (+)(-) Bit
Mata Skru 螺丝批头



5x Makpac Connector Box
Kotak Sambungan Makpac 工具连接箱

CORDLESS COMBO KIT DK0090SWX1

1x Standard Charger (DC18SD)
Pengecas Standard (DC18SD)
标准充电器 (DC18SD)



2x 1.5Ah Battery (BL1815N)
Bateri 1.5Ah (BL1815B)
1.5Ah 电池 (BL1815B)

1x DCL180 Cordless Cleaner (White)
Pembersih Vakum Tanpa Kord (Putih)
充电式便携吸尘器 (白)

1x Filter (443060-3)
Penapis 过滤器
1x Pre Filter (451208-3)
Penapis Depan 前置过滤器



1x Flexible Hose (198867-9)
Hos Fleksibel 软管
1x Round Brush (198877-6)
Berus Bulat 圆刷
1x Shelf Brush (198872-6)
Berus Rata 扁毛刷

1x DF001D 3.6V Cordless Screwdriver (Built-in Battery)
Pemutar Skru Tanpa Kord (Bateri terbina dalam)
充电式螺丝起子机 (内置电池)



1x ADP07 Adapter for USB
Pengecas 充电器



1x Makita Tool Bag (831271-6)
Beg Alat Makita
Makita 工具袋

CORDLESS COMBO KIT DK0089WX1

1x Standard Charger (DC10WD)
Pengecas Standard (DC10WD)
标准充电器 (DC10WD)



2x 1.5Ah Battery (BL1016)
Bateri 1.5Ah (BL1016)
1.5Ah 电池 (BL1016)

1x CL107FD Cordless Cleaner (White)
Pembersih Vakum Tanpa Kord (Putih)
充电式便携吸尘器 (白)

5pcs Paper Filter (194596-1)
Penapis Kartas 纸制尘袋



1x Flexible Hose (198867-9)
Hos Fleksibel 软管
1x Round Brush (198877-6)
Berus Bulat 圆刷
1x Shelf Brush (198872-6)
Berus Rata 扁毛刷

1x DF001D 3.6V Cordless Screwdriver (Built-in Battery)
Pemutar Skru Tanpa Kord (Bateri terbina dalam)
充电式螺丝起子机 (内置电池)



1x ADP07 Adapter for USB
Pengecas 充电器



1x Makita Tool Bag (831271-6)
Beg Alat Makita
Makita 工具袋

CORDLESS COMBO KIT CLX224

1x Standard Charger (DC10WD)
Pengecas Standard (DC10WD)
标准充电器 (DC10WD)



1x TD110D Cordless Impact Driver
Pemutar Skru Impak Tanpa Kord
充电式冲击螺丝起子机
1x 1.5Ah Battery (BL1016)
Bateri 1.5Ah (BL1016)
1.5Ah 电池 (BL1016)



1x DF333D Cordless Driver Drill
Gerudi Pemutar Skru Tanpa Kord
充电式螺丝起子电钻
1x 1.5Ah Battery (BL1016)
Bateri 1.5Ah (BL1016)
1.5Ah 电池 (BL1016)



1x Makita Tool Bag
Beg Alat Makita
Makita 工具袋

CORDLESS COMBO KIT CLX206AX2

1x Standard Charger (DC10WD)
Pengecas Standard (DC10WD)
标准充电器 (DC10WD)



1x TM30D Cordless Multi Tool
Mesin Pemotong Pelbagai Guna Tanpa Kord
充电式多功能切磨机
1x 2.0Ah Battery (BL1021B)
Bateri 2.0Ah (BL1021B)
2.0Ah 电池 (BL1021B)
1x Accessories Set
Set Aksesori 配件套装



1x DF331D Cordless Driver Drill
Gerudi Pemutar Skru Tanpa Kord
充电式螺丝起子电钻
1x 2.0Ah Battery (BL1021B)
Bateri 2.0Ah (BL1021B)
2.0Ah 电池 (BL1021B)
1x Phillips Bit
Mata Skru 螺丝批头



1x Makita Tool Bag (831253-8)
Beg Alat Makita
Makita 工具袋



XGT

40V Li-ion max

XGT X2
80V max



High Power

Kuasa Tinggi 高马力

Durability

Ketahanan 超耐用

Digital Communication

Sistem Pintar 智能系统

Battery

BL4020 (2.0Ah) BL4025 (2.5Ah) BL4040 (4.0Ah) BL4050F (5.0Ah)



Charger

DC40RA DC40RB DC40RC

ADP10 Adapter for LXT Battery





*Compatible batteries

HM002GZ03

Cordless Demolition Hammer

Pemahat Tukul Tanpa Kord
充电式电动槌



*Recommended batteries 4.0Ah, 5.0Ah



- Anti-Vibration Technology (AVT) ensures extra-low vibration performance

Standard Equipment: Bull Point (A-80787), Bit Grease (194683-7), Side Handle, Cloth

• GZ03: Without Charger & Battery



Impact Energy Kekuatan Impak 单次最大冲击力	EPTA-Procedure 05/2009: 20.9J
Impacts Per Minute (IPM) Impak Per Minit 冲击数	950 - 1,900
Shank Diameter Diameter Shank 柄直径	18mm (11/16")
Dimensions (L x W x H) Dimensi 体积	574x146x324mm (22-5/8x5-3/4x12-3/4")
Net Weight Berat Bersih 净重	12.0 - 13.3kg (26.5 - 29.3lbs.)
Work Amount (approx.) Jumlah Kerja 工作量	28.3 kg with BL4040 x2 Concrete Grade 40N/mm ²

HR006GZ 52mm (2-1/16")

Cordless Rotary Hammer

Tukul Putar Tanpa Kord
充电式电钻



*Recommended batteries 4.0Ah, 5.0Ah



- Powerful BL motor delivers 21.4J of impact energy to handle the most demanding applications

Standard Equipment: Side Handle, Side Grip, Depth Gauge, Bit Grease, Cloth

• GZ: Without Charger & Battery



Impact Energy Kekuatan Impak 单次最大冲击力	EPTA-Procedure 05/2009: 21.4J
Capacity Kapasiti 能力	Concrete (TCT Bit): 52mm (2-1/16") Concrete (Core Bit): 160mm (6-5/16")
Impacts Per Minute (IPM) Impak Per Minit 冲击数	1,100 - 2,250
No Load Speed (RPM) Kelajuan Tanpa Beban 回转数	150 - 310
Dimensions (L x W x H) Dimensi 体积	610x140x337mm (24x5-1/2x13-1/4")
Net Weight Berat Bersih 净重	12.9 - 14.3kg (28.4 - 31.5lbs.)

HM001GM202 | HM001GZ

Cordless Demolition Hammer

Pemahat Tukul Tanpa Kord
充电式电动槌



*Recommended batteries 4.0Ah, 5.0Ah



- Anti-Vibration Technology (AVT) ensures extra-low vibration performance

Standard Equipment: Bit Grease (194683-7), Side Grip, Cloth

• GM202: 1x Fast Charger, 2x 4.0Ah Battery
• GZ: Without Charger & Battery



Impact Energy Kekuatan Impak 单次最大冲击力	EPTA-Procedure 05/2009: 9.4J
Impacts Per Minute (IPM) Impak Per Minit 冲击数	0 - 2,650
Shank Diameter Diameter Shank 柄直径	18mm (11/16")
Dimensions (L x W x H) Dimensi 体积	481x113x258mm (19x4-7/16x10-1/8")
Net Weight Berat Bersih 净重	6.3 - 7.1kg (13.9 - 15.7lbs.)
Work Amount (approx.) Jumlah Kerja 工作量	13.6 kg with BL4040 Concrete Grade 40N/mm ²



HR005GM201 | HR005GZ 40mm (1-9/16")

Cordless Rotary Hammer

Tukul Putar Tanpa Kord
充电式电钻



*Recommended batteries 2.0Ah, 2.5Ah, 4.0Ah, 5.0Ah



- Auto-start Wireless System (AWS) connects to compatible vacuum cleaners with Bluetooth

Standard Equipment: Side Handle, Side Grip, Depth Gauge, Bit Grease, Cloth

• GM201: 1x Fast Charger, 2x 4.0Ah Battery
• GZ: Without Charger & Battery



Impact Energy Kekuatan Impak 单次最大冲击力	EPTA-Procedure 05/2009: 8J
Capacity Kapasiti 能力	Concrete (w/ TCT Bit): 40mm (1-9/16")
Impacts Per Minute (IPM) Impak Per Minit 冲击数	1,450 - 2,900
No Load Speed (RPM) Kelajuan Tanpa Beban 回转数	250 - 500
Dimensions (L x W x H) Dimensi 体积	484x117x285mm (19x4-5/8x11-1/4")
Net Weight Berat Bersih 净重	7.5 - 8.0kg (16.5 - 17.6lbs.)
Work Amount (approx.) Jumlah Kerja 工作量	16 holes with BL4040 Concrete Grade 40N/mm ² ø20mm x 140mm depth

HR001GM201 28mm (1-1/8")

Cordless Combination Hammer

Tukul Kombinasi Tanpa Kord
充电式冲击钻锤



*Recommended batteries 2.0Ah, 2.5Ah, 4.0Ah



- Auto-start Wireless System (AWS) connects to vacuum cleaner with Bluetooth



ACCESSORIES (Optional)

DX12 Dust Extraction System Part No. 191E52-3

Standard Equipment: Side Grip, Depth Gauge, Cloth, Grease Vessel (194683-7)

• GM201: 1x Fast Charger, 2x 4.0Ah Battery, 1x Makpac Connector Box



Impact Energy Kekuatan Impak 单次最大冲击力	EPTA-Procedure 05/2009: 2.8J
Capacity Kapasiti 能力	Our experimental conditions: 3.2J Concrete: 28mm(1-1/8") Steel: 13mm(1/2") Wood: 32mm(1-1/4") Core Bit: 54mm(2-1/8") Diamond Core Bit (Dry Type): 65mm (2-9/16")
Impact Per Minute (IPM) Impak Per Minit 冲击数	0 - 5,000
No Load Speed (RPM) Kelajuan Tanpa Beban 回转数	0 - 980
Dimensions (L x W x H) Dimensi 体积	358x102x232mm (14-1/8"x4"x9-1/8")
Net Weight Berat Bersih 净重	3.9 - 4.6kg (8.6 - 10.1lbs.)
Work Amount (approx.) Jumlah Kerja 工作量	138 holes with BL4040 Concrete Grade 40N/mm ² ø10.5mm x 60mm depth

* All list price shown are for reference only (exclude SST).

* Semua harga yang ditunjukkan adalah untuk rujukan sahaja (tidak termasuk SST). 所有显示的建议零售价仅供参考 (不包括SST)。

Cordless
Target: Noisefree

LED Flashlight
Lampu Saha LED
LED照灯

Vacuum Cleaner
Pembersih Vakum
吸尘器

Drilling / Fastening
Gantut / Pasang
钻孔 / 紧固

Impact Drilling / Demolition
Gantut / Pemusnah
冲击钻孔 / 拆除施工

Cutting
Memotong
切割

Grinding / Sanding
Pergasi / Pasah
打磨 / 砂磨

Saving
Gigit
咬切

Planing / Routing
Pergasi / Tanggah
刨平 / 压线

Others
Lain-lain
其他

Outdoor Power Equipment
Alatan Kerja Luar
户外动力工具





*Compatible batteries

HR002GM201 28mm (1-1/8")

Cordless Combination Hammer

Tukul Kombinasi Tanpa Kord
充电式冲击钻锤



*Recommended batteries
2.0Ah, 2.5Ah, 4.0Ah

- Quick change chuck for SDS-plus can be easily exchanged for Quick change drill chuck



Standard Equipment: Side Grip, Depth Gauge, Cloth, Grease Vessel (194683-7), Drill Chuck (199139-5)

- GM201: 1x Fast Charger, 2x 4.0Ah Battery, 1x Makpac Connector Box



Impact Energy Kekuatan Impak 单次最大冲击力	EPTA-Procedure 05/2009: 2.9J
Capacity Kapasiti 能力	Concrete: 28mm(1-1/8") Steel: 13mm(1/2") Wood: 32mm(1-1/4") Core Bit: 54mm(2-1/8") Diamond Core Bit (Dry Type): 65mm (2-9/16")
Impact Per Minute (IPM) Impak Per Minit 冲击数	0 - 5,000
No Load Speed (RPM) Kelajuan Tanpa Beban 回转速	0 - 980
Dimensions (L x W x H) Dimensi 体积	389x102x232mm (15-1/4"x4"x9-1/8")
Net Weight Berat Bersih 净重	4.1 - 4.6kg (9.0 - 10.1lbs.)
Work Amount (approx.) Jumlah Kerja 工作量	138 holes with BL4040 Concrete Grade 40N/mm ² ø10.5mm x 60mm depth

HR003GM201 HR003GZ 28mm (1-1/8")

Cordless Combination Hammer

Tukul Kombinasi Tanpa Kord
充电式冲击钻锤



*Recommended batteries
2.0Ah, 2.5Ah, 4.0Ah

- 3-mode operation for "Rotation Only", "Hammering with Rotation" or "Hammering Only"

ACCESSORIES (Optional)

DX12 Dust Extraction System Part No. 191E52-3



Standard Equipment: Side Grip, Depth Gauge

- GM201: 1x Fast Charger, 2x 4.0Ah Battery
- GZ: Without Charger, Battery & Carrying Case



Impact Energy Kekuatan Impak 单次最大冲击力	EPTA-Procedure 05/2009: 2.8J
Capacity Kapasiti 能力	Our experimental conditions: 3.2J Concrete: 28mm(1-1/8") Steel: 13mm(1/2") Wood: 32mm(1-1/4") Core Bit: 54mm(2-1/8") Diamond Core Bit (Dry Type): 65mm (2-9/16")
Impact Per Minute (IPM) Impak Per Minit 冲击数	0 - 5,000
No Load Speed (RPM) Kelajuan Tanpa Beban 回转速	0 - 980
Dimensions (L x W x H) Dimensi 体积	358x121x232mm (14-1/8"x4-3/4"x9-1/8")
Net Weight Berat Bersih 净重	3.9 - 4.6kg (8.6 - 10.1lbs.)
Work Amount (approx.) Jumlah Kerja 工作量	138 holes with BL4040 Concrete Grade 40N/mm ² ø10.5mm x 60mm depth

HR007GM201 HR007GZ 28mm (1-1/8")

Cordless Combination Hammer

Tukul Kombinasi Tanpa Kord
充电式冲击电钻电锤



*Recommended batteries
2.0Ah, 2.5Ah, 4.0Ah

- 3-mode operation; "rotation only", "hammering with rotation" and "hammering only"



ACCESSORIES (Optional)

DX15 Dust Extraction System Part No. 191X39-9

Standard Equipment: Side Grip, Depth Gauge, Cloth, Grease vessel, Air Duct Cap

- GM201: 1x Fast Charger, 2x 4.0Ah Battery
- GZ: Without Charger, Battery & Carrying Case



Impact Energy Kekuatan Impak 单次最大冲击力	EPTA-Procedure 05/2009: 3.0J
Capacity Kapasiti 能力	Masonry: 28mm (1-1/8") Steel: 13mm (1/2") Wood: 32mm (1-1/4") Core Bit: 54mm (2-1/8") Diamond Core Bit: 65mm (2-9/16")
Impacts Per Minute (IPM) Impak Per Minit 冲击数	0 - 5,000
No Load Speed (RPM) Kelajuan Tanpa Beban 回转速	0 - 980
Dimensions (L x W x H) Dimensi 体积	458x101x234mm (18x4x9-1/4")
Net Weight Berat Bersih 净重	3.8 - 4.8kg (8.4 - 10.6lbs.)
Work Amount (approx.) Jumlah Kerja 工作量	118 holes with BL4040 Concrete Grade 40N/mm ² ø10.5mm x 60mm depth

DF001GD201 DF001GZ 13mm (1/2")

Cordless Driver Drill

Gerudi Pemutar Skru Tanpa Kord
充电式螺丝起子电钻



*Recommended batteries 2.0Ah, 2.5Ah, 4.0Ah, 5.0Ah

- Excellent performance in continuous heavy duty applications



DF001G

Models and specs may vary by country.

Standard Equipment: Side Grip, Belt Clip, (+)(-) Bit, Bit Holder

- GD201: 1x Fast Charger, 2x 2.5Ah Battery, 1x Makpac Connector Box
- GZ: Without Charger, Battery & Carrying Case



Capacity Kapasiti 能力	Steel: 20mm (13/16") Wood (Auger-Bit): 50mm (2") Wood (Self-Feed Bit): 76mm (3") Wood (Hole Saw): 152mm (6") Siding Board: 220mm (8-5/8") 1.5 - 13mm (1/16" - 1/2")
Chuck Capacity Kapasiti Chuck 夹头能力	
No Load Speed (RPM) Kelajuan Tanpa Beban 回转速	High: 0 - 2,600 Low: 0 - 650
Max Fastening Torque Tenaga Pemutaran Pengancing Maksimum 最大紧固扭力	Hard: 140N-m (1,240in.lbs.) Soft: 68N-m (600 in.lbs.)
Max Lock Torque Pemutaran Tenaga Maksimum 最大锁紧扭力	125N-m (1,100in.lbs.)
Dimensions (L x W x H) Dimensi 体积	181x86x275mm (7-1/8"x3-3/8"x10-7/8")
Net Weight Berat Bersih 净重	2.7 - 3.0kg (5.9 - 6.6lbs.)
Work Amount (approx.) Jumlah Kerja 工作量	480 holes with BL4025 Drilled 38mm SPF with 7/8" Auger Bit (High Speed)

DF002GD201 DF002GA201 DF002GZ 13mm (1/2")

Cordless Driver Drill

Gerudi Pemutar Skru Tanpa Kord
充电式螺丝起子电钻



*Recommended batteries 2.0Ah, 2.5Ah, 4.0Ah

- BL motor is electronically controlled to optimize battery energy use for longer run time per charge



Standard Equipment: (+)(-) Bit, Belt Clip

- GD201: 1x Fast Charger, 2x 2.5Ah Battery, 1x Makpac Connector Box
- GA201: 1x Standard Charger, 2x 2.0Ah Battery, 1x Makpac Connector Box
- GZ: Without Charger, Battery & Carrying Case



Capacity Kapasiti 能力	Steel: 13mm (1/2") Wood (Auger Bit): 38mm (1-1/2") Wood (Hole Saw): 51mm (2")
Chuck Capacity Kapasiti Chuck 夹头能力	1.5 - 13mm (1/16" - 1/2")
No Load Speed (RPM) Kelajuan Tanpa Beban 回转速	High: 0 - 2,200 Low: 0 - 600
Max Fastening Torque Tenaga Pemutaran Pengancing Maksimum 最大紧固扭力	Hard: 64N-m (570in.lbs.) Soft: 30N-m (270in.lbs.)
Max Lock Torque Pemutaran Tenaga Maksimum 最大锁紧扭力	65N-m (580in.lbs.)
Clutch Torque Setting Tetapan Pemutaran 扭转设置	1.0 - 5.0N-m (9 - 44in.lbs.)
Dimensions (L x W x H) Dimensi 体积	164x86x272mm (6-1/2"x3-3/8"x10-3/4")
Net Weight Berat Bersih 净重	1.9 - 2.5kg (4.2 - 5.5lbs.)
Work Amount (approx.) Jumlah Kerja 工作量	990 holes with BL4025 30mm thick melapi with ø15mm Auger Bit (High Speed)

* All list price shown are for reference only (exclude SST).

* Semua harga yang ditunjukkan adalah untuk rujukan sahaja (tidak termasuk SST). 所有显示的建议零售价仅供参考 (不包括SST)。

Cordless
Tanpa Kord 无绳式

LED Flashlight
Lampu Suluh LED
LED 照明灯

Vacuum Cleaner
Penyedut Vakuum
吸尘器

Drilling / Fastening
Draut / Pengikat
钻孔 / 紧固

Impact Drilling / Demolition
Draut / Penyahak
冲击钻孔 / 拆除施工

Cutting
Pemotong
切割

Grinding / Sanding
Pengisar / Pasir
打磨 / 砂磨

Sawing
Gergaji
电锯

Planing / Routing
Pengisar / Tangkai
刨削 / 雕刻

Others
Lain-lain
其他

Outdoor Power Equipment
Alatan Kerja Luar
园机-户外





*Compatible batteries

HP001GD201 | HP001GZ 13mm (1/2")

Cordless Hammer Driver Drill

Tukul Pemutar Skru Bergerudi Tanpa Kord
充电式冲击螺丝起子电钻

- Excellent performance in continuous heavy duty applications



*Recommended batteries 2.0Ah, 2.5Ah, 4.0Ah, 5.0Ah



HP001G



VIDEO CLIP
Models and specs may vary by country

Standard Equipment: Depth Gauge, Side Grip, Belt Clip, (+)(-) Bit, Bit Holder

- GD201: 1x Fast Charger, 2x 2.5Ah Battery, 1x Makpac Connector Box
- GZ: Without Charger, Battery & Carrying Case



Capacity Kapasiti 能力	Steel: 20mm (13/16") Wood (Auger-Bit): 50mm (2") Wood (Self-Feed Bit): 76mm (3") Wood (Hole Saw): 152mm (6") Sliding Board: 220mm (8-5/8") Masonry: 20mm (13/16")
Chuck Capacity Kapasiti Chuck 夹头能力	1.5 - 13mm (1/16" - 1/2")
Impacts Per Minute (IPM) Impak Per Minit 冲击数	High: 0 - 39,000 Low: 0 - 9,750
No Load Speed (RPM) Kelajuan Tanpa Beban 回转数	High: 0 - 2,600 Low: 0 - 650
Max Fastening Torque Tenaga Pemutaran Pengancing Maksimum 最大紧固扭力	Hard: 140N-m (1,240in.lbs.) Soft: 68N-m (600 in.lbs.)
Max Lock Torque Pemutaran Tenaga Maksimum 最大锁紧扭力	125N-m (1,100in.lbs.)
Dimensions (L x W x H) Dimensi 体积	182x86x275mm (7-1/8"x3-3/8"x10-7/8")
Net Weight Berat Bersih 净重	2.7 - 3.0kg (6.0 - 6.6lbs.)
Work Amount (approx.) Jumlah Kerja 工作量	480 holes with BL4025 Drilled 38mm SPF with 7/8" Auger Bit (High Speed)

HP002GD201 | HP002GA201 | HP002GZ 13mm (1/2")

Cordless Hammer Driver Drill

Tukul Pemutar Skru Bergerudi Tanpa Kord
充电式冲击螺丝起子电钻

- Variable 2-speed (0-600 & 0-2,200 RPM) for a wide range of drilling, fastening and hammer drilling applications



*Recommended batteries 2.0Ah, 2.5Ah, 4.0Ah, 5.0Ah



Standard Equipment: (+)(-) Bit, Belt Clip

- GD201: 1x Fast Charger, 2x 2.5Ah Battery, 1x Makpac Connector Box
- GA201: 1x Standard Charger, 2x 2.0Ah Battery, 1x Makpac Connector Box
- GZ: Without Charger, Battery & Carrying Case



Capacity Kapasiti 能力	Steel: 13mm (1/2") Wood (Auger Bit): 38mm (1-1/2") Wood (Hole Saw): 51mm (2") Masonry: 13mm (1/2")
Chuck Capacity Kapasiti Chuck 夹头能力	1.5 - 13mm (1/16" - 1/2")
Impacts Per Minute (IPM) Impak Per Minit 冲击数	High: 0 - 33,000 Low: 0 - 9,000
No Load Speed (RPM) Kelajuan Tanpa Beban 回转数	High: 0 - 2,200 Low: 0 - 600
Max Fastening Torque Tenaga Pemutaran Pengancing Maksimum 最大紧固扭力	Hard: 64N-m (570in.lbs.) Soft: 30N-m (270in.lbs.)
Max Lock Torque Pemutaran Tenaga Maksimum 最大锁紧扭力	65N-m (580in.lbs.)
Clutch Torque Setting Tetapan Pemutaran 扭转设置	1.0 - 5.0N-m (9 - 44in.lbs.)
Dimensions (L x W x H) Dimensi 体积	174x86x272mm (6-7/8"x3-3/8"x10-3/4")
Net Weight Berat Bersih 净重	2.0 - 2.6kg (4.4 - 5.7lbs.)
Work Amount (approx.) Jumlah Kerja 工作量	990 holes with BL4025 30mm thick melapi with ø15mm Auger Bit (High Speed)

DA001G Cordless Angle Drill

Net Weight

5.9kg

with BL4040 4.0Ah Battery

Work Amount

with BL4040

four layers of SPF2x10 plate, ø7/8" Auger bit, high speed mode

100 pcs

(approx.)

Front handle

Keyed Drill Chuck
Capacity of drill chuck:
2-13mm (1/16" - 1/2")

Key holder

Mechanical 2-speed

- 1 Low speed (0- 400 min⁻¹)
- 2 High speed (0- 1,500 min⁻¹)

Twin LED job light with preglow and afterglow functions

DA001GZ 13mm (1/2")

Cordless Angle Drill
Gerudi Sudut Tanpa Kord
充电式角向电钻

- Powerful drilling even large diameter holes



*Recommended batteries 2.5Ah, 4.0Ah, 5.0Ah



Standard Equipment: Chuck Key, Chuck Key Holder, Handle Set (191R81-4), Hex Wrench, Hook

- GZ: Without Charger & Battery



Capacity Kapasiti 能力	Steel: 13mm (1/2") Wood (Self-Feed Bit) Hi: 65mm (2-9/16") Wood (Self-Feed Bit) Lo: 118mm (4-5/8") Wood (Hole Saw) Hi: 105mm (4-1/8") Wood (Hole Saw) Lo: 159mm (6-1/4") Wood (Auger-Bit): 50mm (2")
Chuck Capacity Kapasiti Chuck 夹头能力	2 - 13mm (1/16 - 1/2")
No Load Speed (RPM) Kelajuan Tanpa Beban 回转数	High: 0 - 1,500 Low: 0 - 400
Max Fastening Torque Tenaga Pemutaran Pengancing Maksimum 最大紧固扭力	High: 55N-m (487in.lbs.) Low: 136N-m (1,210in.lbs.)
Dimensions (L x W x H) Dimensi 体积	539x128x199mm (21-1/4x5x7-7/8")
Net Weight Berat Bersih 净重	5.3 - 6.2kg (11.7 - 13.7lbs.)

* All list price shown are for reference only (exclude SST).

* Semua harga yang ditunjukkan adalah untuk rujukan sahaja (tidak termasuk SST). 所有显示的建议零售价仅供参考 (不包括SST)。

Cordless
Target: 4000 Series

LED Flashlight
Lampu Suluh LED
LED LIGHT

Vacuum Cleaner
Pembersih Vakuum
吸尘器

Drilling / Fastening
Gerudi / Pengang
钻孔 / 紧固

Impact Drilling / Demolition
Gerudi / Pemusnah
冲击钻孔 / 拆毁施工

Cutting
Pemotong
切割

Grinding / Sanding
Pengkilan / Pencil
研磨 / 砂磨

Sawing
Gergaji
锯切

Planing / Routing
Pengaliran / Tanggung
刨削 / 压边

Others
Lain-lain
其他

Outdoor Power Equipment
Alatan Kuat Luar
户外动力工具





*Compatible batteries

TD001GD201 | TD001GZ

Cordless Impact Driver
Pemutar Skru Impak Tanpa Kord
充电式冲击螺丝起子机



*Recommended batteries 2.0Ah, 2.5Ah, 4.0Ah

- 4-speed power selection plus 6 Assist modes (2 T-modes, 1 Wood mode, 3 Bolt modes)



Standard Equipment: Belt Clip

- GD201: 1x Fast Charger, 2x 2.5Ah Battery, 1x Makpac Connector Box
- GZ: Without Charger, Battery & Carrying Case



Capacity Kapasiti 能力	Machine Screw: M4 - M8 (5/32" - 5/16") Standard Bolt: M5 - M16 (3/16" - 5/8") High Strength Bolt: M5 - M14 (3/16" - 9/16") Coarse thread (in length): 22 - 125 mm (7/8" - 4-7/8") 6.35 mm (1/4")
Hex Shank Batang Heksagon 六角柄	
No Load Speed (RPM) Kelajuan Tanpa Beban 回转数	Max / Hard / Med / Soft / Wood / Bolt (1) / Bolt (2) / Bolt (3) / T (1) / T (2) mode: 0 - 3,700 / 3,200 / 2,100 / 1,100 / 1,800 / 2,500 / 3,700 / 2,400 / 3,700
Impacts Per Minute (IPM) Impak Per Minit 冲击数	Max / Hard / Med / Soft / Wood / Bolt (1) / Bolt (2) / Bolt (3) / T (1) / T (2) mode: 0 - 4,400 / 3,600 / 2,600 / 1,100 / 4,400 / N/A / 4,400 / 4,400 / N/A / 2,600
Max Fastening Torque Tenaga Pemutaran Pengancing Maksimum 最大紧固扭力	220N-m (1,950in.lbs.)
Fastening Torque Tenaga Pemutaran Pengancing 扭力	Hard: 170N-m(1,510in.lbs.) Med: 50N-m(440in.lbs.) Soft: 20N-m (180in.lbs.)
Dimensions (L x W x H) Dimensi 体积	120x86x245mm (4-3/4"x3-3/8"x9-5/8")
Net Weight Berat Bersih 净重	1.7 - 2.0kg (3.7 - 4.4lbs.)
Work Amount (approx.) Jumlah Kerja 工作量	800 pcs with BL4025 Coarse thread screws 65mm

TW001GM201 | TW001GZ 19mm (3/4")

Cordless Impact Wrench
Perengkuh Impak Tanpa Kord
充电式冲击套筒扳手



*Recommended batteries 2.0Ah, 2.5Ah, 4.0Ah

- Higher torque but compact overall length for easy handling and control



Standard Equipment: Belt Clip

- GM201: 1x Fast Charger, 2x 4.0Ah Battery
- GZ: Without Charger, Battery & Carrying Case



Fastening Capacities Kapasiti Pengancing 紧固能力	Standard Bolt: M12 - M36 (1/2" - 1-7/16") High Strength Bolt: M10 - M27 (3/8" - 1-1/16") 19mm (3/4"), C-ring
Square Drive Batang Segi Empat 四方头	
No Load Speed (RPM) Kelajuan Tanpa Beban 回转数	Max: 0 - 1,800 Hard: 1,400 Mid: 1,150 Soft: 950
Impacts Per Minute (IPM) Impak Per Minit 冲击数	Max: 0 - 2,500 Hard: 2,400 Mid: 2,200 Soft: 1,900
Max Fastening Torque Tenaga Pemutaran Pengancing Maksimum 最大紧固扭力	1,800N-m (1,330ft.lbs.)
Nut-Busting Torque Tork Pembongkaran Maksimum 最大拆卸扭力	2,050N-m (1,510ft.lbs.)
Dimensions (L x W x H) Dimensi 体积	217x94x297mm (8-1/2"x3-11/16"x11-3/4")
Net Weight Berat Bersih 净重	3.9 - 4.2kg (8.6 - 9.3lbs.)
Work Amount (approx.) Jumlah Kerja 工作量	870pcs with BL4040 x2 Tightening of M24 bolts

TW007GM204 | TW007GD202 | TW007GZ02 12.7mm (1/2")

Cordless Impact Wrench
Perengkuh Impak Tanpa Kord
充电式冲击套筒扳手



*Recommended batteries 2.0Ah, 2.5Ah, 4.0Ah

- 3 modes of reaction time for automatic stop available both in forward and reverse rotation modes

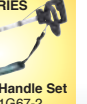
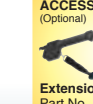

Standard Equipment: Belt Clip, Ring Set with Shoulder Belt

- GM204: 1x Fast Charger, 2x 4.0Ah Battery, 1x Makpac Connector Box
- GD202: 1x Fast Charger, 2x 2.5Ah Battery, 1x Makpac Connector Box
- GZ02: Without Charger & Battery



Fastening Capacities Keupayaan Pengancing 紧固能力	Standard Bolt: M10 - M24 (3/8 - 1") High Strength Bolt (Grade 10.9): M10 - M16 (3/8 - 5/8") High Strength Bolt (Grade F10T): M12, M16 (7/16, 5/8") 12.7mm (1/2")
Square Drive Skru Persegi 方形螺柱	
No Load Speed (RPM) Kelajuan Tanpa Beban 回转数	Max: 0 - 2,300 Hard: 0 - 1,900 Mid: 0 - 1,200 Soft: 0 - 600
Impacts Per Minute (IPM) Impak Per Minit 冲击数	Max: 0 - 2,900 Hard: 0 - 2,700 Mid: 0 - 1,900 Soft: 0 - 1,200
Max Fastening Torque Tenaga Pemutaran Pengancing Maksimum 最大紧固扭力	760N-m (560ft.lbs.)
Nut-Busting Torque Tork Pembongkaran Maksimum 最大拆卸扭力	1,100N-m (810ft.lbs.)
Dimensions (L x W x H) Dimensi 体积	170x86x285mm (6-11/16x3-3/8x11-1/4")
Net Weight Berat Bersih 净重	2.7 - 3.3kg (6.0 - 7.3lbs.)
Work Amount (approx.) Jumlah Kerja 工作量	460pcs with BL4040 x2 Tightening of M16 bolts

TW008GZ 12.7mm (1/2")

Cordless Impact Wrench
Perengkuh Impak Tanpa Kord
充电式冲击套筒扳手



*Recommended batteries 2.0Ah, 2.5Ah, 4.0Ah

- 3 modes of reaction time for automatic stop available both in forward and reverse rotation modes



Standard Equipment: Belt Clip

- GZ: Without Charger & Battery



Fastening Capacities Keupayaan Pengancing 紧固能力	Standard Bolt: M10 - M24 (3/8 - 1") High Strength Bolt (Grade 10.9): M10 - M16 (3/8 - 5/8") High Strength Bolt (Grade F10T): M12, M16 (7/16, 5/8") 12.7mm (1/2")
Square Drive Skru Persegi 方形螺柱	
No Load Speed (RPM) Kelajuan Tanpa Beban 回转数	Max: 0 - 2,300 Hard: 0 - 1,900 Mid: 0 - 1,200 Soft: 0 - 600
Impacts Per Minute (IPM) Impak Per Minit 冲击数	Max: 0 - 2,900 Hard: 0 - 2,700 Mid: 0 - 1,900 Soft: 0 - 1,200
Max Fastening Torque Tenaga Pemutaran Pengancing Maksimum 最大紧固扭力	760N-m (560ft.lbs.)
Nut-Busting Torque Tork Pembongkaran Maksimum 最大拆卸扭力	1,100N-m (810ft.lbs.)
Dimensions (L x W x H) Dimensi 体积	170x86x285mm (6-11/16x3-3/8x11-1/4")
Net Weight Berat Bersih 净重	2.7 - 3.3kg (6.0 - 7.3lbs.)

TW005GD201 | TW005GZ 12.7mm (1/2")

Cordless Impact Wrench
Perengkuh Impak Tanpa Kord
充电式冲击套筒扳手



*Recommended batteries 2.0Ah, 2.5Ah, 4.0Ah

- 3 modes of reaction time for automatic stop available both in forward and reverse rotation modes



Standard Equipment: Belt Clip, Tool Hanger Set (191K57-9)

- GD201: 1x Fast Charger, 2x 2.5Ah Battery, 1x Makpac Connector Box
- GZ: Without Charger, Battery & Carrying Case



Fastening Capacities Keupayaan Pengancing 紧固能力	Standard Bolt: M10 - M20 (3/8 - 3/4") High Strength Bolt: M10 - M16 (3/8 - 5/8") 12.7mm (1/2"), Pin detent
Square Drive Skru Persegi 方形螺柱	
No Load Speed (RPM) Kelajuan Tanpa Beban 回转数	Max: 0 - 3,200 Hard: 2,600 Medium: 1,800 Soft: 1,000
Impacts Per Minute (IPM) Impak Per Minit 冲击数	Max: 0 - 4,000 Hard: 3,400 Medium: 2,600 Soft: 1,800
Max Fastening Torque Tenaga Pemutaran Pengancing Maksimum 最大紧固扭力	350N-m (260ft.lbs.)
Nut-Busting Torque Tork Pembongkaran Maksimum 最大拆卸扭力	630N-m (465ft.lbs.)
Dimensions (L x W x H) Dimensi 体积	144x86x248mm (5-5/8x3-3/8x9-3/4")
Net Weight Berat Bersih 净重	1.9 - 2.2kg (4.2 - 4.9lbs.)
Work Amount (approx.) Jumlah Kerja 工作量	560pcs with BL4025 x2 Tightening of M16 bolts

* All list price shown are for reference only (exclude SST).

* Semua harga yang ditunjukkan adalah untuk rujukan sahaja (tidak termasuk SST). 所有显示的建议零售价仅供参考 (不包括SST)。

Cordless
Tanpa Kord 充电式
LED Flashlight
Lampu Suluh LED
LED 照明灯

Vacuum Cleaner
Pembersih Vakuum
吸尘器

Drilling / Fastening
Draut / Pengangat
钻孔 / 紧固

Impact Drilling / Demolition
Draut / Penanggal
起土钻孔 / 拆墙加工

Cutting
Pemotong
切割

Grinding / Sanding
Pengisar / Pencil
磨削 / 打磨

Sawing
Gergaji
电锯

Planing / Routing
Pengisar / Tangkapan
刨削 / 磨削

Others
Lain-lain
其他

Outdoor Power Equipment
Alatan Kerja Luar
园具-户外





*Compatible batteries

Cordless Angle Grinder

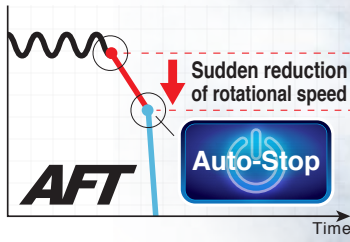

Shuts down the tool to protect the user, if the rotation speed suddenly slows down



AFT

Delivers same power as 1,000W corded grinders

Model No. / 型号			No Load Speed (rpm) / Kelajuan Tanpa Beban / 回转数	Switch / Suis / 开关	BL MOTOR	XPT	AFT	BRAKE	AWS	Anti-restart function / Fungsi restart semula / 防重启功能	XLOCK
100mm	125mm	150mm									
GA003G	GA005G	GA035G	8,500	Slide	•	•	•	•	•	•	
GA011G	GA013G	GA036G	8,500	Paddle	•	•	•	•	•	•	
GA021G	GA023G	-	3,000 - 8,500	Slide	•	•	•	•	•	•	
GA027G	GA029G	-	3,000 - 8,500	Paddle	•	•	•	•	•	•	
GA042G	GA044G	-	3,000 - 8,500	Paddle	•	•	•	•	•	•	•

GA003GM201 | GA003GD201 | GA003GZ 100mm (4")

Cordless Angle Grinder
Pengisar Sudut Tanpa Kord
充电式角向磨光机

Top Slide Switch
Suis Gelangsar Atas 顶部滑动开关
Convenient for left & right handed
Mudah diguna dengan tangan kiri atau kanan 方便左右手

*Recommended batteries 2.5Ah, 4.0Ah, 5.0Ah

- Excellent in continuous heavy-duty work

Standard Equipment: Grinding Wheel (A-80852), Wheel Cover, Side Grip, Lock Nut Wrench

- GM201: 1x Fast Charger, 2x 4.0Ah Battery
- GD201: 1x Fast Charger, 2x 2.5Ah Battery
- GZ: Without Charger, Battery & Carrying Case

Icons: XGT, BL MOTOR, XPT, AFT, BRAKE

Wheel Diameter Diameter Roda 轮片直径	100mm (4")
Hole Diameter Diameter Lubang 孔直径	16mm (5/8")
Max Wheel Thickness Ketebalan Roda Maksimum 最大轮片厚度	6.4mm (1/4")
No Load Speed (RPM) Kelajuan Tanpa Beban 回转数	8,500
Dimensions (L x W x H) Dimensi 体积	398x117x150mm (15-5/8"x4-5/8"x5-7/8")
Net Weight Berat Bersih 净重	2.8 - 3.3kg (6.2 - 7.3lbs.)

GA011GM201 | GA011GD201 | GA011GZ 100mm (4")

Cordless Angle Grinder
Pengisar Sudut Tanpa Kord
充电式角向磨光机

Paddle Switch
Suis Pemicu 扳机开关

*Recommended batteries 2.5Ah, 4.0Ah, 5.0Ah

- Genuine solution for high demand industrial applications

Standard Equipment: Grinding Wheel (A-80852), Wheel Cover, Side Grip, Lock Nut Wrench

- GM201: 1x Fast Charger, 2x 4.0Ah Battery
- GD201: 1x Fast Charger, 2x 2.5Ah Battery
- GZ: Without Charger, Battery & Carrying Case

Icons: XGT, BL MOTOR, XPT, AFT, BRAKE

Wheel Diameter Diameter Roda 轮片直径	100mm (4")
Hole Diameter Diameter Lubang 孔直径	16mm (5/8")
Max Wheel Thickness Ketebalan Roda Maksimum 最大轮片厚度	6.4mm (1/4")
No Load Speed (RPM) Kelajuan Tanpa Beban 回转数	8,500
Dimensions (L x W x H) Dimensi 体积	398x117x150mm (15-5/8"x4-5/8"x5-7/8")
Net Weight Berat Bersih 净重	2.8 - 3.4kg (6.2 - 7.5lbs.)

GA021GM201 | GA021GD201 | GA021GZ 100mm (4")

Cordless Angle Grinder
Pengisar Sudut Tanpa Kord
充电式角向磨光机

Top Slide Switch
Suis Gelangsar Atas 顶部滑动开关
Convenient for left & right handed
Mudah diguna dengan tangan kiri atau kanan 方便左右手

*Recommended batteries 2.5Ah, 4.0Ah, 5.0Ah

- Auto-start Wireless System (AWS) connects to compatible vacuum cleaners with Bluetooth

Standard Equipment: Grinding Wheel (A-80852), Wheel Cover, Side Grip, Lock Nut Wrench

- GM201: 1x Fast Charger, 2x 4.0Ah Battery
- GD201: 1x Fast Charger, 2x 2.5Ah Battery
- GZ: Without Charger, Battery & Carrying Case

Icons: XGT, BL MOTOR, XPT, AFT, AWS, BRAKE

Wheel Diameter Diameter Roda 轮片直径	100mm (4")
Hole Diameter Diameter Lubang 孔直径	16mm (5/8")
Max Wheel Thickness Ketebalan Roda Maksimum 最大轮片厚度	6.4mm (1/4")
No Load Speed (RPM) Kelajuan Tanpa Beban 回转数	3,000 - 8,500
Dimensions (L x W x H) Dimensi 体积	413x117x150mm (16-1/4"x4-5/8"x5-7/8")
Net Weight Berat Bersih 净重	2.8 - 3.4kg (6.2 - 7.5lbs.)

* All list price shown are for reference only (exclude SST).

* Semua harga yang ditunjukkan adalah untuk rujukan sahaja (tidak termasuk SST). 所有显示的建议零售价仅供参考 (不包括SST)。

Cordless
Target: 无绳工具

LED Flashlight
Lampu Suhu LED
LED手电筒

Vacuum Cleaner
Pembersih Vakuum
吸尘器

Drilling / Fastening
Ganda / Pengikat
钻孔 / 紧固

Impact Drilling / Demolition
Ganda / Pengikat
冲击钻孔 / 拆除

Cutting
Pemotong
切割

Grinding / Sanding
Pengisar / Habis
研磨 / 打磨

Sanding
Ganda
打磨

Planing / Routing
Pengisar / Tangan
刨平 / 雕刻

Others
Lain-lain
其他

Outdoor Power Equipment
Alatan Kuat Luar
户外动力

Thakita
TENT



*Compatible batteries

GA027GM201 | GA027GD201 | GA027GZ 100mm (4")

Cordless Angle Grinder
Pengisar Sudut Tanpa Kord
充电式角向磨光机

Paddle Switch
Suis Pemacu 扳机开关

*Recommended batteries
2.5Ah, 4.0Ah, 5.0Ah



- Auto-start Wireless System (AWS) connects to compatible vacuum cleaners with Bluetooth

Standard Equipment: Grinding Wheel (A-80852), Wheel Cover, Side Grip, Lock Nut Wrench

- GM201: 1x Fast Charger, 2x 4.0Ah Battery
- GD201: 1x Fast Charger, 2x 2.5Ah Battery
- GZ: Without Charger, Battery & Carrying Case



Wheel Diameter Diameter Roda 轮片直径	100mm (4")
Hole Diameter Diameter Lubang 孔直径	16mm (5/8")
Max Wheel Thickness Ketebalan Roda Maksimum 最大轮片厚度	6.4mm (1/4")
No Load Speed (RPM) Kelajuan Tanpa Beban 回转数	3,000 - 8,500
Dimensions (L x W x H) Dimensi 体积	413x117x150mm (16-1/4"x4-5/8"x5-7/8")
Net Weight Berat Bersih 淨重	2.9 - 3.4kg (6.4 - 7.5lbs.)

GA042GM201 | GA042GD201 | GA042GZ 100mm (4")

Cordless Angle Grinder
Pengisar Sudut Tanpa Kord
充电式角向磨光机

Paddle Switch
Suis Pemacu 扳机开关

*Recommended batteries
2.5Ah, 4.0Ah, 5.0Ah



- Excellent in continuous heavy-duty work
- X-LOCK for toolless accessory changes

Standard Equipment: Depressed Center Wheel, Cutting Wheel Cover Attachment, Toolless Wheel Cover, Side Grip

- GM201: 1x Fast Charger, 2x 4.0Ah Battery
- GD201: 1x Fast Charger, 2x 2.5Ah Battery, 1x Makpac Connector Box
- GZ: Without Charger, Battery & Carrying Case



Wheel Diameter Diameter Roda Pengisar 砂轮片直径	100mm (4")
Hole Diameter Diameter Lubang 孔直径	22.23mm (7/8")
Max Wheel Thickness Ketebalan Roda Maksimum 最大轮片厚度	6mm (1/4")
No Load Speed (RPM) Kelajuan Tanpa Beban 回转数	3,000 - 8,500
Dimensions (L x W x H) Dimensi 体积	433x117x162mm (17x4-5/8x6-3/8")
Net Weight Berat Bersih 淨重	3.0 - 5.4kg (6.6 - 11.9lbs.)

GA005GM201 | GA005GD201 | GA005GZ 125mm (5")

Cordless Angle Grinder
Pengisar Sudut Tanpa Kord
充电式角向磨光机

Top Slide Switch
Suis Gelasar Atas 顶部滑动开关
Convenient for left & right handed
Mudah diguna dengan tangan kiri atau kanan 方便左右手

*Recommended batteries
2.5Ah, 4.0Ah, 5.0Ah



- Genuine solution for high demand industrial applications

Standard Equipment: Grinding Wheel (A-80656), Wheel Cover, Side Grip, Lock Nut Wrench

- GM201: 1x Fast Charger, 2x 4.0Ah Battery
- GD201: 1x Fast Charger, 2x 2.5Ah Battery
- GZ: Without Charger, Battery & Carrying Case



Wheel Diameter Diameter Roda 轮片直径	125mm (5")
Hole Diameter Diameter Lubang 孔直径	22.23mm (7/8")
Max Wheel Thickness Ketebalan Roda Maksimum 最大轮片厚度	7.2mm (9/32")
No Load Speed (RPM) Kelajuan Tanpa Beban 回转数	8,500
Dimensions (L x W x H) Dimensi 体积	398x140x156mm (15-5/8"x5-1/2"x6-1/8")
Net Weight Berat Bersih 淨重	2.9 - 3.6kg (6.4 - 7.9lbs.)

GA013GM201 | GA013GD201 | GA013GZ 125mm (5")

Cordless Angle Grinder
Pengisar Sudut Tanpa Kord
充电式角向磨光机

Paddle Switch
Suis Pemacu 扳机开关

*Recommended batteries
2.5Ah, 4.0Ah, 5.0Ah



- BL motor to run cooler and more efficiently for longer life

Standard Equipment: Grinding Wheel (A-80656), Wheel Cover, Side Grip, Lock Nut Wrench

- GM201: 1x Fast Charger, 2x 4.0Ah Battery
- GD201: 1x Fast Charger, 2x 2.5Ah Battery
- GZ: Without Charger, Battery & Carrying Case



Wheel Diameter Diameter Roda 轮片直径	125mm (5")
Hole Diameter Diameter Lubang 孔直径	22.23mm (7/8")
Max Wheel Thickness Ketebalan Roda Maksimum 最大轮片厚度	7.2mm (9/32")
No Load Speed (RPM) Kelajuan Tanpa Beban 回转数	8,500
Dimensions (L x W x H) Dimensi 体积	398x140x156mm (15-5/8"x5-1/2"x6-1/8")
Net Weight Berat Bersih 淨重	3.0 - 3.6kg (6.6 - 7.9lbs.)



GA023GM201 | GA023GD201 | GA023GZ 125mm (5")

Cordless Angle Grinder
Pengisar Sudut Tanpa Kord
充电式角向磨光机

Top Slide Switch
Suis Gelasar Atas 顶部滑动开关
Convenient for left & right handed
Mudah diguna dengan tangan kiri atau kanan 方便左右手

*Recommended batteries
2.5Ah, 4.0Ah, 5.0Ah



- Auto-start Wireless System (AWS) connects to compatible vacuum cleaners with Bluetooth

Standard Equipment: Grinding Wheel (A-80656), Wheel Cover, Side Grip, Lock Nut Wrench

- GM201: 1x Fast Charger, 2x 4.0Ah Battery, 1x Makpac Connector Box
- GD201: 1x Fast Charger, 2x 2.5Ah Battery, 1x Makpac Connector Box
- GZ: Without Charger, Battery & Carrying Case



Wheel Diameter Diameter Roda 轮片直径	125mm (5")
Hole Diameter Diameter Lubang 孔直径	22.23mm (7/8")
Max Wheel Thickness Ketebalan Roda Maksimum 最大轮片厚度	7.2mm (9/32")
No Load Speed (RPM) Kelajuan Tanpa Beban 回转数	3,000 - 8,500
Dimensions (L x W x H) Dimensi 体积	413x140x156mm (16-1/4"x5-1/2"x6-1/8")
Net Weight Berat Bersih 淨重	3.0 - 4.4kg (6.6 - 9.7lbs.)

* All list price shown are for reference only (exclude SST).

* Semua harga yang ditunjukkan adalah untuk rujukan sahaja (tidak termasuk SST). 所有显示的建议零售价仅供参考 (不包括SST)。

Cordless
Tanpa Kord 无绳式

LED Flashlight
Lampu Suluh LED
LED 照明灯

Vacuum Cleaner
Pembersih Vakuum
吸尘器

Drilling / Fastening
Mamali / Pasang
钻孔 / 紧固

Impact Drilling / Demolition
Garuhi / Persekit
冲击钻孔 / 拆除加工

Cutting
Pemotong
切割

Grinding / Sanding
Pengisar / Pasir
磨削 / 打磨

Sawing
Gergaji
电锯

Planing / Routing
Pengamir / Tampat
刨削 / 雕刻

Others
Lain-lain
其他

Outdoor Power Equipment
Alatan Kuasa Luar
园具-户外

Makita
MAKITA

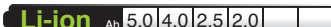

*Compatible batteries

GA029GM201 | GA029GD201 | GA029GZ 125mm (5")

Cordless Angle Grinder
Pengisar Sudut Tanpa Kord
充电式角向磨光机



Paddle Switch
Suis Pemicu 扳机开关

*Recommended batteries
2.5Ah, 4.0Ah, 5.0Ah



- Auto-start Wireless System (AWS) connects to compatible vacuum cleaners with Bluetooth

Standard Equipment: Grinding Wheel (A-80656), Wheel Cover, Side Grip, Lock Nut Wrench

- GM201: 1x Fast Charger, 2x 4.0Ah Battery
- GD201: 1x Fast Charger, 2x 2.5Ah Battery
- GZ: Without Charger, Battery & Carrying Case



Wheel Diameter Diameter Roda 轮片直径	125mm (5")
Hole Diameter Diameter Lubang 孔直径	22.23mm (7/8")
Max Wheel Thickness Ketebalan Roda Maksimum 最大轮片厚度	7.2mm (9/32")
No Load Speed (RPM) Kelajuan Tanpa Beban 回转数	3,000 - 8,500
Dimensions (L x W x H) Dimensi 体积	413x140x156mm (16-1/4"x5-1/2"x6-1/8")
Net Weight Berat Bersih 净重	3.0 - 4.5kg (6.6 - 9.9lbs.)

GA044GM201 | GA044GD201 | GA044GZ 125mm (5")

Cordless Angle Grinder
Pengisar Sudut Tanpa Kord
充电式角向磨光机



Paddle Switch
Suis Pemicu 扳机开关

*Recommended batteries
2.5Ah, 4.0Ah, 5.0Ah



- Genuine solution for high demand industrial applications
- X-LOCK for toolless accessory changes

Standard Equipment: Depressed Center Wheel, Cutting Wheel Cover Attachment, Toolless Wheel Cover, Side Grip

- GM201: 1x Fast Charger, 2x 4.0Ah Battery
- GD201: 1x Fast Charger, 2x 2.5Ah Battery, 1x Makpac Connector Box
- GZ: Without Charger, Battery & Carrying Case



Wheel Diameter Diameter Roda Pengisar 砂轮片直径	125mm (5")
Hole Diameter Diameter Lubang 孔直径	22.23mm (7/8")
Max Wheel Thickness Ketebalan Roda Maksimum 最大轮片厚度	6mm (1/4")
No Load Speed (RPM) Kelajuan Tanpa Beban 回转数	3,000 - 8,500
Dimensions (L x W x H) Dimensi 体积	433x140x163mm (17x5-1/2x6-3/8")
Net Weight Berat Bersih 净重	3.0 - 5.4kg (6.6 - 11.9lbs.)

GA035GZ 150mm (6")

Cordless Angle Grinder
Pengisar Sudut Tanpa Kord
充电式角向磨光机



Top Slide Switch
Suis Gelas Atas 顶部滑动开关

Convenient for left & right handed
Mudah diguna dengan tangan kiri atau kanan 方便左右手

*Recommended batteries
2.5Ah, 4.0Ah, 5.0Ah



- Improved heat dissipation capacity of the controller allows for continuous heavy-duty applications

Standard Equipment: Grinding Wheel (A-80846), Toolless Wheel Cover, Side Grip, Lock Nut Wrench

- GZ: Without Charger & Battery



Wheel Diameter Diameter Roda Pengisar 砂轮片直径	150mm (6")
Hole Diameter Diameter Lubang 孔直径	22.23mm (7/8")
Max Wheel Thickness Ketebalan Roda Maksimum 最大轮片厚度	6.4mm (1/4")
No Load Speed (RPM) Kelajuan Tanpa Beban 回转数	8,500
Dimensions (L x W x H) Dimensi 体积	398x171x156mm (15-5/8x6-3/4x6-1/8")
Net Weight Berat Bersih 净重	3.0-4.0kg (6.6-8.8lbs.)



GA036GZ 150mm (6")

Cordless Angle Grinder
Pengisar Sudut Tanpa Kord
充电式角向磨光机



Paddle Switch
Suis Pemicu 扳机开关

*Recommended batteries
2.5Ah, 4.0Ah, 5.0Ah



- Improved heat dissipation capacity of the controller allows for continuous heavy-duty applications

Standard Equipment: Grinding Wheel (A-80846), Toolless Wheel Cover, Side Grip, Lock Nut Wrench

- GZ: Without Charger & Battery



Wheel Diameter Diameter Roda Pengisar 砂轮片直径	150mm (6")
Hole Diameter Diameter Lubang 孔直径	22.23mm (7/8")
Max Wheel Thickness Ketebalan Roda Maksimum 最大轮片厚度	6.4mm (1/4")
No Load Speed (RPM) Kelajuan Tanpa Beban 回转数	8,500
Dimensions (L x W x H) Dimensi 体积	398x171x156mm (15-5/8x6-3/4x6-1/8")
Net Weight Berat Bersih 净重	3.0-4.0kg (6.6-8.8lbs.)



GA037GT201 | GA037GM201 | GA037GZ 180mm (7")

Cordless Angle Grinder
Pengisar Sudut Tanpa Kord
充电式角向磨光机



Paddle Switch
Suis Pemicu 扳机开关

*Recommended batteries 5.0Ah



- Auto-start Wireless System (AWS) Connects to Compatible Vacuum Cleaners with Bluetooth

Standard Equipment: Toolless Wheel Cover, Side Grip, Lock Nut Wrench

- GT201: 1x Fast Charger, 2x 5.0Ah Battery
- GM201: 1x Fast Charger, 2x 4.0Ah Battery
- GZ: Without Charger & Battery



Wheel Diameter Diameter Roda Pengisar 砂轮片直径	180mm (7")
Hole Diameter Diameter Lubang 孔直径	22.23mm (7/8")
Max Wheel Thickness Ketebalan Roda Maksimum 最大轮片厚度	7.2mm (1/4")
No Load Speed (RPM) Kelajuan Tanpa Beban 回转数	7,800
Dimensions (L x W x H) Dimensi 体积	499x200x180mm (19-5/8x7-7/8x7-1/8")
Net Weight Berat Bersih 净重	4.4 - 5.2kg (9.7 - 11.0lbs.)
Work Amount (approx.) Jumlah Kerja 工作量	8.0 m with BL4050F Concrete cutting 30mm depth with Diamond Wheel

* All list price shown are for reference only (exclude SST).

* Semua harga yang ditunjukkan adalah untuk rujukan sahaja (tidak termasuk SST). 所有显示的建议零售价仅供参考 (不包括SST)。

Cordless
Tanpa Kord 充电式

LED Flashlight
Lampu Suhu LED
LED照明灯

Vacuum Cleaner
Pembersih Vakuum
吸尘器

Drilling / Fastening
Ganda / Pasang
钻孔 / 紧固

Impact Drilling / Demolition
Ganda / Hancurkan
冲击钻孔 / 拆除施工

Cutting
Pemotong
切割

Grinding / Sanding
Pengisar / Pasir
研磨 / 砂磨

Sawing
Gergaji
锯切

Planing / Routing
Pengaliran / Tangan
刨削 / 压花

Others
Lain-lain
其他

Outdoor Power Equipment
Alatan Kuasa Luar
园机 / 户外

Thakita
Power Tools



*Compatible batteries

GA038GT201 | GA038GM201 | GA038GZ 230mm (9")

Cordless Angle Grinder
Pengisar Sudut Tanpa Kord
充电式角向磨光机



Paddle Switch
Suis Pemacu 扳机开关

*Recommended batteries 5.0Ah



- Auto-start Wireless System (AWS) Connects to Compatible Vacuum Cleaners with Bluetooth

Standard Equipment: Toolless Wheel Cover, Side Grip, Lock Nut Wrench

- GT201: 1x Fast Charger, 2x 5.0Ah Battery
- GM201: 1x Fast Charger, 2x 4.0Ah Battery
- GZ: Without Charger & Battery



Wheel Diameter Diameter Roda Pengisar 砂轮片直径	230mm (9")
Hole Diameter Diameter Lubang 孔直径	22.23mm (7/8")
Max Wheel Thickness Ketebalan Roda Maksimum 最大砂轮片厚度	6.5mm (1/4")
No Load Speed (RPM) Kelajuan Tanpa Beban 回转数	6,600
Dimensions (L x W x H) Dimensi 体积	509x250x164mm (20x9-7/8x6-1/2")
Net Weight Berat Bersih 净重	4.6 - 7.4kg (10.1 - 16.3lbs.)
Work Amount (approx.) Jumlah Kerja 工作量	5.0 m with BL4050F Concrete cutting 30mm depth with Diamond Wheel

PV001G Cordless Polisher



3-Position loop handle



Easy-to-grip head shape

enables user to easily press the pad to the car body in applications such as scratch removal with polishing compound

Variable speed control by dial
Max rotation speed can be selected to suit application



with indication of max rotation speed



PV001GM101 | PV001GZ

Cordless Polisher
Penggilap Tanpa Kord
充电式打蜡机



*Recommended batteries 2.5Ah, 4.0Ah, 5.0Ah



- Designed mainly for polishing applications in car painting business

Standard Equipment: Loop Handle (413F67-9), Side Handle (158237-4), Hex Wrench, Wool Pad 180 (192629-7), Sleeve 18 (262542-4), Backing Pad (743053-3), Dust Cover

- GM101: 1x Fast Charger, 1x 4.0Ah Battery, 1x Tool Bag
- GZ: Without Charger & Battery



Brush Pad Capacity Kapasiti Pad 刷垫能力	180mm (7")
Pad Diameter Diameter Pad 垫片直径	165mm (6-1/2")
Spindle Thread Size Saiz Spinde 主轴尺寸	M14
No Load Speed (RPM) Kelajuan Tanpa Beban 回转数	By Trigger: 0 - 2,200 By Dial: 600 - 2,200
Dimensions (L x W x H) Dimensi 体积	516x196x195mm (20-1/4x7-3/4x7-5/8")
Net Weight Berat Bersih 净重	3.0 - 4.4kg (6.6 - 9.7lbs.)
Continuous Usage Time (approx.) Masa Penggunaan Berterusan 连续使用时间	42 min with BL4025 with load of 3.5 - 4.0kg, at 600 min ⁻¹

SP001GZ02 165mm (6-1/2")

Cordless Plunge Cut Saw
Gergaji Piring Tanpa Kord
充电式圆锯



*Recommended batteries 2.5Ah, 4.0Ah, 5.0Ah



- High power for fast cutting and ripping
- Optional guide rail is attachable without adapter for increased maneuverability

Standard Equipment: TCT Saw Blade (B-57364), Hex Wrench

- GZ02: With 1x Makpac Connector Box, Without Charger & Battery



Blade Diameter Diameter Bilah 锯片直径	165mm (6-1/2")
Hole Diameter Diameter Lubang 孔直径	20mm (13/16")
Bevel Capacity Kapasiti Bevel 斜角容量	-1 - 48°
Max Cutting Capacity Kapasiti Pemotongan Maksimum 最大切割能力	0°: 56mm (2-3/16") 45°: 40mm (1-9/16") 48°: 38mm (1-1/2") 2,500 - 4,900
No Load Speed (RPM) Kelajuan Tanpa Beban 回转数	2,500 - 4,900
Dimensions (L x W x H) Dimensi 体积	347x221x271mm (13-5/8x8-3/4x10-5/8")
Net Weight Berat Bersih 净重	4.4 - 5.0kg (9.7 - 11.0lbs.)
Work Amount (approx.) Jumlah Kerja 工作量	150 cuts Kitchen board (Laminate wood) thickness 40mm x width 600mm 0° cutting

* All list price shown are for reference only (exclude SST).

* Semua harga yang ditunjukkan adalah untuk rujukan sahaja (tidak termasuk SST). 所有显示的建议零售价仅供参考 (不包括SST)。

Cordless Target Kord 无绳式
LED Flashlight Lampu Suluh LED LED 照明灯
Vacuum Cleaner Pemilauhi VAKUUM 吸尘器
Drilling / Fastening Druai / Pengikat 钻式 / 紧固
Impact Drilling / Demolition Druai / Perseki 钻式 / 拆毁加工
Cutting Pemotong 切割
Grinding / Sanding Pengisar / Pasir 磨削 / 研磨
Sawing Gergaji 锯切
Planing / Routing Pengisar / Tampat 刨削 / 雕刻
Others Lain-lain 其他
Outdoor Power Equipment Alatan Kerja Luar 园具-户外





*Compatible batteries

LS003GZ 305mm (12")

Cordless Slide Compound Miter Saw

Gergaji Kompaun Miter Tanpa Kord
充电式斜断锯



*Recommended batteries 4.0Ah, 5.0Ah



- Auto-start Wireless System (AWS) connects to compatible vacuum cleaners with Bluetooth

Standard Equipment: TCT Saw Blade (B-67452), Dust Bag, Triangular Rule, Vertical Vise, Hex Wrench

• GZ: Without Charger & Battery



Blade Diameter Diameter Bilah 锯片直径	305mm (12")
Hole Diameter Diameter Lubang 孔直径	25.4mm (1")
Angle Sudut 角度	Miter: 60°L / 60°R Bevel: 48°L / 48°R
Max Cutting Capacity Kapastiti Pemotongan Maksimum 最大切割能力	0° Miter: 107x363mm (4-1/4x14-1/4") 45° Miter, L/R: 107x255mm (4-1/4x10") 3,600
No Load Speed (RPM) Kelajuan Tanpa Beban 回转数	
Dimensions (L x W x H) Dimensi 体积	898x690x725mm (35-1/4x27-1/4x28-1/2")
Net Weight Berat Bersih 净重	30.5 - 31.1kg (67.2 - 68.6lbs.)
Work Amount (approx.) Jumlah Kerja 工作量	70 cuts with BL4040 Melapi thickness 90mm x width 300mm at 90° side cutting

LS004GZ 260mm (10-1/4")

Cordless Slide Compound Miter Saw

Gergaji Kompaun Miter Tanpa Kord
充电式斜断锯



*Recommended batteries 4.0Ah, 5.0Ah



- Auto-start Wireless System (AWS) connects to compatible vacuum cleaners with Bluetooth

Standard Equipment: TCT Saw Blade, Dust Bag, Triangular Rule, Vertical Vise, Hex Wrench

• GZ: Without Charger & Battery



Blade Diameter Diameter Bilah 锯片直径	260mm (10-1/4")
Hole Diameter Diameter Lubang 孔直径	25.4mm (1")
Angle Sudut 角度	Miter: 60°L / 60°R Bevel: 48°L / 48°R
Max Cutting Capacity Kapastiti Pemotongan Maksimum 最大切割能力	0° Miter: 91x279mm (3-5/8x11") 45° Miter, L/R: 91x197mm (3-5/8x7-3/4") 3,600
No Load Speed (RPM) Kelajuan Tanpa Beban 回转数	
Dimensions (L x W x H) Dimensi 体积	805x644x660mm (31-1/4x25-3/8x26")
Net Weight Berat Bersih 净重	26.6 - 27.2kg (58.6 - 60.0lbs.)
Work Amount (approx.) Jumlah Kerja 工作量	110 cuts with BL4040 Melapi thickness 90mm x width 300mm at 90° side cutting

LS002GZ 216mm (8-1/2")

Cordless Slide Compound Miter Saw

Gergaji Kompaun Miter Tanpa Kord
充电式斜断锯



*Recommended batteries 2.5Ah, 4.0Ah, 5.0Ah



- Auto-start Wireless System (AWS) connects to compatible vacuum cleaners with Bluetooth

Standard Equipment: Efficut TCT Saw Blade (E-07010), Dust Bag, Triangular Rule, Vertical Vise, Hex Wrench

• GZ: Without Charger & Battery



Blade Diameter Diameter Bilah 锯片直径	216mm (8-1/2")
Hole Diameter Diameter Lubang 孔直径	25.4mm (1")
Angle Sudut 角度	Miter: 60°L / 60°R Bevel: 48°L / 48°R
Max Cutting Capacity Kapastiti Pemotongan Maksimum 最大切割能力	(Bevel 45°L / Miter 45°LR) 50x220mm (2x8-5/8") (Bevel 45°L / Miter 0°) 50x312mm (2x12-1/4") (Bevel 45°R / Miter 45°LR) 30x220mm (1-3/16x8-5/8") (Bevel 45°R / Miter 0°) 30x312mm (1-3/16x12-1/4") (Bevel 0° / Miter 45°LR) 70x220mm (2-3/4x8-5/8") (Bevel 0° / Miter 0°) 70x312mm (2-3/4x12-1/4") 4,800
No Load Speed (RPM) Kelajuan Tanpa Beban 回转数	
Dimensions (L x W x H) Dimensi 体积	702x551x557mm (27-5/8x21-3/4x22")
Net Weight Berat Bersih 净重	16.4 - 17.0kg (36.2 - 37.6lbs.)
Work Amount (approx.) Jumlah Kerja 工作量	170 cuts with BL4040 Melapi thickness 60mm x width 250mm at 90° side cutting

HS011GT201 | **HS011GZ** 260mm (10-1/4") / 270mm (10-5/8")

Cordless Circular Saw

Gergaji Piring Tanpa Kord
充电式圆锯



*Recommended batteries 5.0Ah



- Large size BL motor delivers high power similar or superior to corded models

Standard Equipment: TCT Saw Blade (E-07733), Sub Base, Hex Wrench

- GT201: 1x Fast Charger, 2x 5.0Ah Battery
- GZ: Without Charger & Battery



Blade Diameter Diameter Bilah 锯片直径	260 - 270mm (10-1/4 - 10-5/8")
Max Cutting Capacity Kapastiti Pemotongan Maksimum 最大切割能力	0°: 97 - 101mm (3-13/16 - 4") 45°: 68 - 71mm (2-11/16 - 2-13/16") 60°: 48 - 51mm (1-7/8 - 2")
No Load Speed (RPM) Kelajuan Tanpa Beban 回转数	3,500
Dimensions (L x W x H) Dimensi 体积	453x196x336mm (17-7/8x7-3/4x13-1/4")
Net Weight Berat Bersih 净重	5.5 - 6.7kg (12.1 - 14.8lbs.)
Work Amount (approx.) Jumlah Kerja 工作量	40 cuts with BL4050F Sawing with EFFICUT blade 0° cut Melapi Wood (thickness 90mm, width 1,000mm)

HS009GT201 | **HS009GZ** 235mm (9-1/4")

Cordless Circular Saw

Gergaji Piring Tanpa Kord
充电式圆锯



*Recommended batteries 5.0Ah



- Lightweight & High Power
- Directly compatible with guide rail

Standard Equipment: TCT Saw Blade (E-01959), Sub Base, Hex Wrench

- GT201: 1x Fast Charger, 2x 5.0Ah Battery
- GZ: Without Charger & Battery



Blade Diameter Diameter Bilah 锯片直径	235mm (9-1/4")
Max Cutting Capacity Kapastiti Pemotongan Maksimum 最大切割能力	0°: 85mm (3-3/8") 45°: 61mm (2-3/8") 60°: 44mm (1-3/4")
No Load Speed (RPM) Kelajuan Tanpa Beban 回转数	4,000
Dimensions (L x W x H) Dimensi 体积	413x196x316mm (16-1/4x7-3/4x12-1/2")
Net Weight Berat Bersih 净重	5.1 - 5.7kg (11.2 - 12.6lbs.)
Work Amount (approx.) Jumlah Kerja 工作量	120 pcs with BL4050F Sawing with EFFICUT blade 0° cut Oak Wood (thickness 80mm, width 300mm)

* All list price shown are for reference only (exclude SST).

* Semua harga yang ditunjukkan adalah untuk rujukan sahaja (tidak termasuk SST). 所有显示的建议零售价仅供参考 (不包括SST)。

Cordless Targeted Jobs

LED Flashlight Lampu Saha LED LED 手电筒

Vacuum Cleaner Pembersih Vakuum 吸尘器

Drilling / Fastening Gergaji / Pasak Drill / Pasak 钻孔 / 紧固

Impact Drilling / Demolition Gergaji / Pasak Gergaji / Pasak 冲击钻孔 / 拆除

Cutting Pemotongan 切割

Grinding / Sanding Pengkilan / Pasak 研磨 / 砂磨

Sawing Gergaji 锯切

Planing / Routing Pengkilan / Pasak 刨削 / 雕刻

Others Lain-lain 其他

Outdoor Power Equipment Alatan Kerja Luar 户外动力设备

Thakita



*Compatible batteries

HS004GM201 | HS004GZ 190 / 185mm (7-1/2" / 7-1/4")

Cordless Circular Saw
Gergaji Piring Tanpa Kord
充电式圆锯



*Recommended batteries 4.0Ah, 5.0Ah



- Lightweight & High Power

Standard Equipment: TCT Saw Blade (B-62022), Dust Nozzle, Hex Wrench, Guide Rule

- GM201: 1x Fast Charger, 2x 4.0Ah Battery
- GZ: Without Charger, Battery & Carrying Case



Blade Diameter Diameter Bilah 锯片直径	190mm (7-1/2") 185mm (7-1/4")
Max Cutting Capacity Kapasiti Pemotongan Maksimum 最大切割能力	90°: 62.5 / 60 mm (2-7/16" / 2-3/8") 45°: 44.5 / 43 mm (1-3/4" / 1-11/16") 48°: 42 / 41 mm (1-5/8" / 1-5/8")
No Load Speed (RPM) Kelajuan Tanpa Beban 回转速	6,000
Dimensions (L x W x H) Dimensi 体积	322x210x290mm (12-5/8"x8-1/4"x11-3/8")
Net Weight Berat Bersih 淨重	4.4 - 4.7kg (9.7 - 10.4lbs.)
Work Amount (approx.) Jumlah Kerja 工作量	145pcs Melapi thickness: 60mm, width: 300mm 31pcs SPF 2 x 10 with BL4040

JR002G

Cordless Recipro Saw

Work Amount
with BL4025
Carbon Steel Pipe (25A)

55 cuts
(approx.)

Variable speed control by dial enables user to adjust the max cutting strokes to match the materials of workpiece.



Tool-less shoe adjustment



Anti-drop mechanism for Shoe

- minimizes drop of shoe when adjusting the position of Shoe.
- Shoe can be removed simply by operating a lever and a button.

Orbital mechanism
For high speed wood cutting



Orbital cutting action



For fast cutting in wood and autoclaved lightweight concrete

Straight line cutting action



For cutting iron pipes, cast iron pipes, aluminum, stainless steel and plastics

JR002GM201 | JR002GZ

Cordless Recipro Saw
Gergaji Resipro Tanpa Kord
充电式往复锯



*Recommended batteries 2.0Ah, 2.5Ah, 4.0Ah, 5.0Ah



- High power delivered by the BL motor designed to best suit XGT battery

Standard Equipment: Recipro Saw Blades 3pcs (B-05153 Wood) (B-05044 Wood with nail) (B-05038 Metal)

- GM201: 1x Fast Charger, 2x 4.0Ah Battery
- GZ: Without Charger, Battery & Carrying Case



Length of Stroke Panjang Strok 冲程长度	32mm (1-1/4")
Strokes Per Minute (SPM) Kelajuan Strok 冲程速度	0 - 3,000
Capacity Kapasiti 能力	Wood: 255mm (10") Pipe: 130mm (5-1/8")
Dimensions (L x W x H) Dimensi 体积	451x97x256mm (17-3/4x3-13/16x10-1/8")
Net Weight Berat Bersih 淨重	4.6 - 5.8kg (10.1 - 12.8lbs.)
Work Amount (approx.) Jumlah Kerja 工作量	55 cuts with BL4025 Carbon steel pipe (25A)

JR001GM201 | JR001GZ

Cordless Recipro Saw
Gergaji Resipro Tanpa Kord
充电式往复锯



*Recommended batteries 2.0Ah, 2.5Ah, 4.0Ah



- Compact & High Power

Standard Equipment: Recipro Saw Blades 3pcs (B-05153 Wood) (B-05044 Wood with nail) (B-05038 Metal)

- GM201: 1x Fast Charger, 2x 4.0Ah Battery
- GZ: Without Charger, Battery & Carrying Case



Length of Stroke Panjang Strok 冲程长度	32mm (1-1/4")
Strokes Per Minute (SPM) Kelajuan Strok 冲程速度	High: 0 - 3,000 Low: 0 - 2,300
Capacity Kapasiti 能力	Pipe: 130mm (5-1/8") Wood: 255mm (10")
Dimensions (L x W x H) Dimensi 体积	457x88x233mm (18"x3-1/2"x9-1/8")
Net Weight Berat Bersih 淨重	4.2 - 4.5kg (9.3 - 9.9lbs.)
Work Amount (approx.) Jumlah Kerja 工作量	155cuts with BL4040 SPF 2 x 10



* All list price shown are for reference only (exclude SST).

* Semua harga yang ditunjukkan adalah untuk rujukan sahaja (tidak termasuk SST). 所有显示的建议零售价仅供参考 (不包括SST)。

Cordless Target Kord 无绳
LED Flashlight Lampu Suluh LED LED 照明灯
Vacuum Cleaner Pembersih Vakuum 吸尘器
Drilling / Fastening Dremel / Pengikat 钻 / 紧固
Impact Drilling / Demolition Dremel / Pemukul 冲击钻 / 拆除加工
Cutting Pemotong 切割
Grinding / Sanding Pengisar / Poles 打磨 / 抛光
Sawing Gergaji 电锯
Planing / Routing Pengisar / Tampam 刨 / 铣
Others Lain-lain 其他
Outdoor Power Equipment Alatan Kerja Luar 户外户外





*Compatible batteries

PB002GM201 | PB002GZ

Cordless Portable Band Saw
Gergaji Pita Tanpa Kord
充电式带锯机



*Recommended batteries 2.0Ah, 2.5Ah, 4.0Ah



• Designed mainly for cutting 4" to 4-1/2" steel pipes efficiently

Standard Equipment: Band Saw Blade, Hex Wrench

- GM201: 1x Fast Charger, 2x 4.0Ah Battery
- GZ: Without Charger, Battery & Carrying Case



*Not applicable for Z model



Capacity Kapasiti 能力	Round: 127mm (5") Square: 127 x 127mm (5 x 5")
Blade Speed Kelajuan Bilah 刀片速度	0 - 3.2m/min (0 - 630ft/min)
Blade Size Saiz Bilah 锯片尺寸	Length: 1,140mm (45") Width: 13mm (1/2") Thickness: 0.5mm (0.02")
Dimensions (L x W x H) Dimensi 体积	510x218x314mm (20x8-5/8x12-3/8")
Net Weight Berat Bersih 净重	6.6 - 7.8kg (14.6 - 17.2lbs.)
Work Amount Jumlah Kerja 工作量	31 pcs with BL4040 Cutting (4" carbon steel pipe 100A) (6.0mm Thickness)

CS002G Cordless Metal Cutter



Max Cutting Capacity

67mm



Work Amount

with BL4050F
Saw Blade - Cut 2-1/2" equal angle steel bars (t=6.0mm)

210 pcs
(approx.)

Improvement in ease to attach / detach Dust box



using a mechanism which allows for attaching/detaching simply by one-hand operation of a plastic lever



for fast blade changes



for fast saw dust disposal

CS002GZ 185mm (7-1/4")

Cordless Metal Cutter
Pemotong Logam Tanpa Kord
充电式金属切割机



*Recommended batteries 2.5Ah, 4.0Ah, 5.0Ah



• Designed mainly for single-pass cutting of 65mm metal studs, 2-1/2" equal angle steel bars and lip channel steel bars

Standard Equipment: TCT Saw Blade (E-12918), Hex Wrench, Safety Goggles, Guide Rule

- GZ: Without Charger & Battery



Wheel Diameter Diameter Bilah 锯片直径	185mm (7-1/4")
Hole Diameter Diameter Lubang 孔直径	20mm (13/16")
Max Cutting Capacity Kapasiti Pemotongan Maksimum 最大切割能力	0": 67mm (2-5/8")
No Load Speed (RPM) Kelajuan Tanpa Beban 回转速	3,500
Dimensions (L x W x H) Dimensi 体积	350x232x270mm (13-3/4x9-1/8x10-5/8")
Net Weight Berat Bersih 净重	4.2 - 5.4kg (9.3 - 11.9lbs.)
Work Amount Jumlah Kerja 工作量	210 pcs with BL4050F Saw Blade - Cut 2-1/2" equal angle steel bars (t=6.0mm)

* All list price shown are for reference only (exclude SST).

* Semua harga yang ditunjukkan adalah untuk rujukan sahaja (tidak termasuk SST). 所有显示的建议零售价仅供参考 (不包括SST)。

Cordless
Tanpa Kord / Tanpa Kabel

LED Flashlight
Lampu Sulu LED
LED 闪光灯

Vacuum Cleaner
Pembersih Vakuum
吸尘器

Drilling / Fastening
Gergaji / Pengikat
钻孔 / 紧固

Impact Drilling / Demolition
Gergaji / Pemusnah
冲击钻孔 / 拆除施工

Cutting
Pemotong
切割

Grinding / Sanding
Pengkilan / Pemoles
打磨 / 砂磨

Sawing
Gergaji
锯切

Planing / Routing
Pengkilan / Tanganan
刨削 / 造型

Others
Lain-lain
其他

Outdoor Power Equipment
Alatan Kuat Luar
户外动力设备





CE001G Cordless Power Cutter

Work Amount

with BL4050F x2

Concrete Cutting
50mm depth x 300mm wide
with Diamond Wheel

18cuts
(approx.)



Max Cutting
Capacity

127mm

Low vibration

Front handle | Rear handle

2.0 | 1.2
m/s

[Concrete cutting]

Equipped with
anti-vibration housing

with built-in spring to absorb the
vibration from cutting to integrated
front and rear handles

Anti-vibration spring



Anti-vibration housing

Drive unit



LED job light

- can be turned on/off with a button conveniently located on the rear handle.
- automatically shuts off when the switch trigger is not pulled for 60 seconds.



WG | IPX4
WET GUARD

High water-resistance allows to
operate the machine even if it is
wet with water

XPT Enhanced Dust
and Drip-proof
Performance ensure reliable
operation even under bad weather

CE001GZ01 80Vmax

Cordless Power Cutter
Mesin Pemotong Tanpa Kord
充电式切磨机



*Recommended batteries 5.0Ah



- WetGuard/ IPX4-compatible; High water-resistance allows to operate the machine even if it is wet with water

Standard Equipment:
Diamond Wheel (E-12996),
Wrench, Coupling Sleeve, Ring

• GZ01: Without Charger & Battery



VIDEO CLIP
Models and specs
may vary by country



Wheel Diameter Diameter Bilah 锯片直径	355mm (14")
Wheel Hole Diameter Diameter Lubang 孔直径	25.4mm (1")
Max Wheel Thickness Ketebalan Roda Maksimum 最大轮片厚度	5.0mm (3/16")
Min Wheel Thickness Ketebalan Roda Minimum 最小轮片厚度	2.0mm (5/64")
Max Cutting Capacity Kapasiti Pemotongan Maksimum 最大切割能力	127mm (5")
No Load Speed (RPM) Kelajuan Tanpa Beban 回转速	5,300
Dimensions (L x W x H) Dimensi 体积	786x272x433mm (31x10-3/4x17")
Net Weight Berat Bersih 净重	12.3 - 14.1kg (27.1 - 31.1lbs.)
Work Amount (approx.) Jumlah Kerja 工作量	18 cuts with BL4050F x2 Concrete Cutting 50mm depth x 300mm wide with Diamond Wheel

RT001GM212 | RT001GZ23 | RT001GZ24 6.35mm (1/4"), 9.53mm (3/8")

Cordless Trimmer
Mesin Perapi Tanpa Kord
充电式修边机



*Recommended batteries 2.0Ah, 2.5Ah, 4.0Ah



- Compatible with the bases used for DRT50
- Soft brake prevents work materials damaged

Standard Equipment: Collet Cone 1/4" (763637-1) 3/8" (763619-3),
Trimmer Base Assembly, Straight Guide, Templet Guide, Wrench, Dust Nozzle

- GM212 : 1x Fast Charger, 2x 4.0Ah Battery, 1x Makpac Connector Box
- GZ23 : Without Charger, Battery & Carrying Case
- GZ24 : Plunge Base Assembly (195563-0), Tilt Base Assembly (198987-9),
Trimmer Guide, Guide Rail Adapter Set,
Without Charger, Battery & Carrying Case



Max Output Keluaran Maksima 最大输出	1,160W
Collet Size Kapasiti Collet 夹头直径	6.35mm (1/4"), 9.53mm (3/8") Optional: 6mm (1/4"), 8mm (3/8")
No Load Speed (RPM) Kelajuan Tanpa Beban 回转速	10,000 - 31,000
Plunge Capacity Kapasiti Plunge 能力	Trimmer Base: 0 - 40mm (0 - 1-9/16") Plunge Base: 0 - 35mm (0 - 1-3/8")
Dimensions (L x W x H) Dimensi 体积	126x90x245mm (5x3-1/2x9-5/8")
Net Weight Berat Bersih 净重	2.2 - 2.5kg (4.9 - 5.5lbs.)
Work Amount (approx.) Jumlah Kerja 工作量	170 m with BL4040 Cut 1m Long Groove in Melapi 6mm Depth with o6mm Straight Bit

* All list price shown are for reference only (exclude SST).

* Semua harga yang ditunjukkan adalah untuk rujukan sahaja (tidak termasuk SST). 所有显示的建议零售价仅供参考 (不包括SST)。

Cordless
Tanpa Kord 充电式

LED Flashlight
Lampu Suluh LED
LED 闪光灯

Vacuum Cleaner
Pembersih Vakuum
吸尘器

Drilling / Fastening
Drobul / Pengikat
钻孔 / 紧固

Impact Drilling / Demolition
Drobul / Penembak
冲击钻孔 / 拆除加工

Cutting
Pemotong
切割

Grinding / Sanding
Pengisar / Pasir
打磨 / 砂磨

Sawing
Gergaji
电锯

Planing / Routing
Pengisar / Tampat
刨平 / 刨花

Others
Lain-lain
其他

Outdoor Power Equipment
Alatan Kerja Luar
园林-户外





KP001G Cordless Planer



Work Amount with BL4040

67mm wide x 1,000mm long (Douglas fir) (depth 2.0mm)

95m
(approx.)

AWS Auto-start Wireless System Bluetooth

Wireless unit is compatible with all supported tools Part No. 199393-1

Optional Accessories

Knob with click stops provides precise planing depth setting by rubberized adjustment knob with click stops and easy-to-read scale

Front base with 3 chamfering grooves

- Easy chamfering by aligning the groove with the edge of workpiece.
- 3 different grooves are provided.

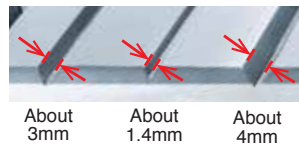

Foot on base plate

protects workpiece and blade from scratches and damages even if the machine is put on workpiece before drum comes to a complete halt



Max. Planing Depth: Up to 4mm (1/8")

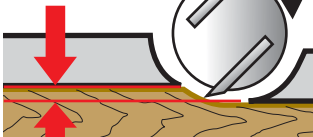

Shiplapping cuts: Up to 25mm (1")



KP001GM201 KP001GZ 82mm (3-1/4")

Cordless Planer
Pengetam Tanpa Kord
充电式电刨



*Recommended batteries 2.0Ah, 2.5Ah, 4.0Ah



- Smooth planing similar or better than corded models in the same class for both rough planing and thin planing

Standard Equipment: Planer Blade, Blade Gauge, Guide Rule, Depth Guide, Socket Wrench, Sharpening Holder

- GM201: 1x Fast Charger, 2x 4.0Ah Battery
- GZ: Without Charger, Battery & Carrying Case



Planing Width Lebar Pelan 刨削宽度	82mm (3-1/4")
Planing Depth Kedalaman Pelan 刨削深度	4mm (5/32")
No Load Speed (RPM) Kelajuan Tanpa Beban 回转数	15,000
Dimensions (L x W x H) Dimensi 体积	385x156x166mm (15-1/8x6-1/8x6-1/2")
Net Weight Berat Bersih 净重	3.7 - 4.9kg (8.2 - 10.8lbs.)
Work Amount (approx.) Jumlah Kerja 工作量	95 m with BL4040 67mm wide x 1,000mm long (Douglas fir) (depth 2.0mm)

FN001GD101 FN001GZ

Cordless Brad Nailer
Mesin Pemaku Tanpa Kord
充电式打钉机



*Recommended batteries 2.0Ah, 2.5Ah



- High power to drive brad nails up to 40mm; 35mm into hard materials such as red oak

Standard Equipment: Safety Goggles, Nose Adapter, Hex Wrench, Belt Clip

- GD101: 1x Fast Charger, 1x 2.5Ah Battery
- GZ: Without Charger, Battery & Carrying Case



Capacity Kapasiti 能力	Length: 15 - 40mm (5/8" - 1-5/8") Gauge: 18Ga
Magazine Capacity Bilangan Staples 装订个数	100
Dimensions (L x W x H) Dimensi 体积	265x86x243mm (10-3/8x3-3/8x9-9/16")
Net Weight Berat Bersih 净重	2.6 - 3.2kg (5.7 - 7.1lbs.)
Work Amount (approx.) Jumlah Kerja 工作量	5000pcs with BL4025 Nail: Length 15-40mm, Gauge 18Ga

Accessories (optional)			
Description	Size	Pcs/ Box	Part No.
Brad Nail 15mm (5/8")	F15	5,000	B-04307
Brad Nail 20mm (3/4")	F20	5,000	B-04313
Brad Nail 25mm (1")	F25	5,000	B-04329
Brad Nail 30mm (1-3/16")	F30	5,000	B-04335
Brad Nail 35mm (1-3/8")	F35	5,000	B-04357

PT001GD101 PT001GZ

Cordless Pin Nailer
Mesin Pemaku Tanpa Kord
充电式打钉机



*Recommended batteries 2.0Ah, 2.5Ah



- Low reaction force mechanism enables easier long pin nailing and high-quality finish

Standard Equipment: Nose Adapter, Safety Goggles (195246-2), Belt Clip, Hex Wrench

- GD101: 1x Fast Charger, 1x 2.5Ah Battery
- GZ: Without Charger, Battery & Carrying Case



Capacity Kapasiti 能力	Length: 15, 18, 25, 30, 35 mm (5/8, 11/16, 1, 1-3/16, 1-3/8") Dia.: 0.6 mm (1/32") Gauge: 23 Ga
Magazine Capacity Bilangan Staples 装订个数	120
Dimensions (L x W x H) Dimensi 体积	265x86x226mm (10-3/8x3-3/8x8-7/8")
Net Weight Berat Bersih 净重	2.4 - 3.0kg (5.3 - 6.6lbs.)
Work Amount (approx.) Jumlah Kerja 工作量	6000 pcs with BL4025

Accessories (optional)			
Description	Size	Pcs/ Box	Part No.
Pin Nail 18mm (11/16")	P18	10,000	F-31825
Pin Nail 25mm (1")	P25	10,000	F-31838
Pin Nail 30mm (1-3/16")	P30	10,000	F-31841
Pin Nail 35mm (1-3/8")	P35	10,000	F-31854

* All list price shown are for reference only (exclude SST).

* Semua harga yang ditunjukkan adalah untuk rujukan sahaja (tidak termasuk SST). 所有显示的建议零售价仅供参考 (不包括SST)。

Cordless Targeted Jobs

LED Flashlight Lampu Saku LED LED 手电筒

Vacuum Cleaner Penembuh Vakuum 吸尘器

Drilling / Fastening Gergaji / Pengikat 电钻 / 紧固件

Impact Drilling / Demolition Gergaji / Penembuh 电钻 / 拆毁工具

Cutting Pemotong 切割机

Grinding / Sanding Pengkilan / Poles 打磨 / 砂磨

Sawing Gergaji 锯切

Planing / Routing Pengkilan / Tangkapan 刨削 / 封边

Others Lain-lain 其他

Outdoor Power Equipment Alatan Kuasa Luar 户外动力工具



*Compatible batteries

AS001G Cordless Dust Blower

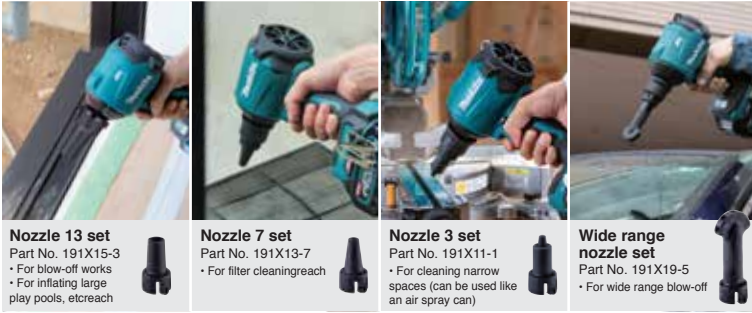

Nozzle 13 set
Part No. 191X15-3
• For blow-off works
• For inflating large play pools, etc/reach

Nozzle 7 set
Part No. 191X13-7
• For filter cleaning/reach

Nozzle 3 set
Part No. 191X11-1
• For cleaning narrow spaces (can be used like an air spray can)

Wide range nozzle set
Part No. 191X19-5
• For wide range blow-off



Easy nozzle replacement without tool

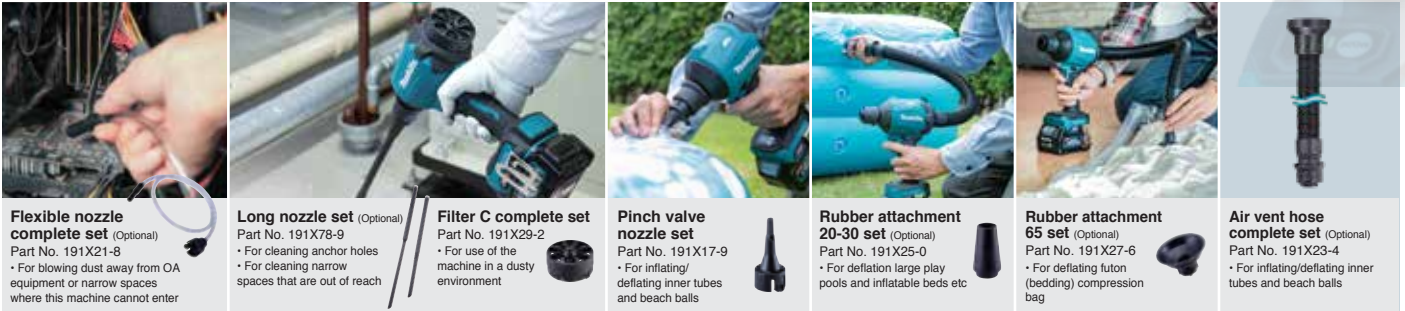

Flexible nozzle complete set (Optional)
Part No. 191X21-8
• For blowing dust away from OA equipment or narrow spaces where this machine cannot enter

Long nozzle set (Optional)
Part No. 191X78-9
• For cleaning anchor holes
• For cleaning narrow spaces that are out of reach

Filter C complete set
Part No. 191X29-2
• For use of the machine in a dusty environment

Pinch valve nozzle set
Part No. 191X17-9
• For inflating/deflating inner tubes and beach balls

Rubber attachment 20-30 set (Optional)
Part No. 191X25-0
• For deflation large play pools and inflatable beds etc

Rubber attachment 65 set (Optional)
Part No. 191X27-6
• For deflating futon (bedding) compression bag

Air vent hose complete set (Optional)
Part No. 191X23-4
• For inflating/deflating inner tubes and beach balls

AS001GA105 | AS001GZ03

Cordless Dust Blower
Mesin Penghembus Habuk Tanpa Kord
充电式除尘器



*Recommended batteries 2.0Ah, 2.5Ah, 4.0Ah

• 4 stage air volume; selectable according to your application

Standard Equipment: Nozzle 3, Nozzle 7, Nozzle 13, Pinch Valve Nozzle, Wide Range Nozzle, Filter C

• GA105 : 1x Standard Charger, 1x 2.0Ah Battery, Accessory Bag, Makita Tool Bag (831253-8)
• GZ03 : Without Charger & Battery



*Not applicable for Z model



Max Blowing Force Kekuatan Tiupan Maksimum 最大吹力	Mode: 4: 2.8N 3: 2.3N 2: 1.7N 1: 1.1N
Max Air Volume Isipadu Angin Maksimum 最大风量	Mode: 4: 1.1m³/min 3: 1.0m³/min 2: 0.8m³/min 1: 0.6m³/min
Max Sealed Suction Sedutan Terkedap 最大密封吸力	10.3kPa
Dimensions (L x W x H) Dimensi 体积	180x94x248mm (7-1/8x3-11/16x9-3/4")
Net Weight Berat Bersih 净重	1.5 - 2.3kg (3.3 - 5.1 lbs.)
Continuous Usage Time (approx.) Masa Penggunaan Berterusan 连续使用时间	Mode: 4: 13 min 3: 17 min 2: 25 min 1: 50 min with BL4025

MP001G Cordless Inflator



	MP001G	Light Truck	Car	Tractor	Bicycle	Road Bike	Ball	Beach ball / Swim ring
Valve Shape								
Adapter			American		British	French	For Balls	For Swim rings/Beach balls
Objects Conditions	Size: 205/70R16 0→600kPa High speed mode	Size: 215/60R16 0→250kPa High speed mode	Size: 7-14 0→180kPa High speed mode	Size: 26 inch 0→300kPa Low speed mode	Size: 700x23C 0→700kPa High speed mode	Size: 700x23C 0→90kPa Ball mode	Size: 30cm High speed mode	
Work Speed (approx)	8 min 25 sec	2 min 45 sec	1 min 40 sec	9 sec	17 sec	39 sec	22 sec	
Work Amount Battery BL4040	4 times	19 times	32 times	780 times	125 times	310 times	140 times	

MP001GZ

Cordless Inflator
Inflator Tanpa Kord
充电式打气机



*Recommended batteries 2.0Ah, 2.5Ah, 4.0Ah, 5.0Ah

• Ideal for inflating tires of cars and bicycles, sport balls, and more

Standard Equipment: British Adapter, French Adapter, Ball Adapter, Swim Ring Adapter

• GZ: Without Charger & Battery



Max Air Pressure Udara Tekanan Maksimum 最大气压	1,110kPa (161 PSI) [11.1 bar]
Air Discharge Amount Pelepasan Udara 空气排放量	200kPa: 24L/min 700kPa: 12L/min
Hose Length Panjang Hos 软管长度	65cm (25-1/2")
Dimensions (L x W x H) Dimensi 体积	320x108x231mm (12-5/8x4-1/4x9-1/8")
Net Weight Berat Bersih 净重	2.9 - 3.5kg (6.4 - 7.7lbs.)

* All list price shown are for reference only (exclude SST).

* Semua harga yang ditunjukkan adalah untuk rujukan sahaja (tidak termasuk SST). 所有显示的建议零售价仅供参考 (不包括SST)。

Cordless Target Model 充电式
LED Flashlight Lampu Sulu LED LED 充电式
Vacuum Cleaner Pembersih Vakuum 吸尘器
Drilling / Fastening Dremel / Pengikat 电钻 / 螺絲
Impact Drilling / Demolition Gergaji / Pemusnah 电钻 / 螺絲
Cutting Pemotong 切割机
Grinding / Sanding Pengisar / Poles 磨床 / 砂纸
Sawing Gergaji 电锯
Planing / Routing Pengisar / Tangkapan 刨床 / 磨床
Others Lain-lain 其他
Outdoor Power Equipment Alatan Kerja Luar 户外动力设备





*Compatible batteries

UR012GZ02 80Vmax

Cordless Grass Trimmer
Pemotong Rumput Tanpa Kord
充电式割草机



*Recommended batteries 5.0Ah

- Applicable to heavy-duty operation due to high output power similar to 40mL class engine grass trimmers

Standard Equipment: Safety Goggles, Metal Blade, Nylon Cutting Head, Plastic Blade, Accessory Bag, Hex Wrench, Box Wrench, Shoulder Belt

• GZ02: Without Charger & Battery



Max Output Keluaran Maksima 最大输出	2,000W
Cutting Width Lebar Keratan 切割宽度	Metal Blade: 305mm (12") Chisel Blade: 225mm (8-7/8") Shredder Blade: 270mm (10-5/8") TCT Saw Blade: 255mm (10") Nylon Cutting Head: 480mm (18-7/8") Plastic Blade: 305mm (12")
No Load Speed (RPM) Kelajuan Tanpa Beban 回转速	Metal Blade / Plastic Blade (305mm): High: 0 - 6,800 Mid: 0 - 5,000 Low: 0 - 3,500 Nylon Cutting Head: High: 0 - 5,000 Mid: 0 - 4,200 Low: 0 - 3,500 M10 x 1.25LH
Spindle Size Saiz Spinde 主轴尺寸	M10 x 1.25LH
Dimensions (L x W x H) Dimensi 体积	1,790x680x590mm (70-1/2x26-3/4x23-1/4")
Net Weight Berat Bersih 净重	8.0 - 9.3kg (17.6 - 20.5lbs.)
Continuous Usage Time (approx.) Masa Penggunaan Berterusan 连续使用时间	Low: 126 min Med: 84 min High: 56 min with BL4050F x2 (Metal Blade)

UR007GM101 | UR007GZ01

Cordless Grass Trimmer
Pemotong Rumput Tanpa Kord
充电式割草机



*Recommended batteries 2.5Ah, 4.0Ah, 5.0Ah

- Wet Guard/ IPX4-compatible; High water-resistance allows to operate the machine even if it is wet with water

Standard Equipment: Safety Goggles, Metal Blade, Nylon Cutting Head, Plastic Blade, Accessory Bag, Hex Wrench, Box Wrench, Shoulder Belt

• GM101: 1x Fast Charger, 1x 4.0Ah Battery
• GZ01: Without Charger & Battery

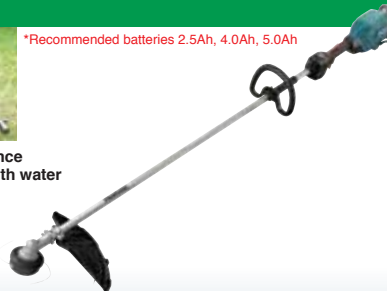

Max Output Keluaran Maksima 最大输出	1,000W
Cutting Width Lebar Keratan 切割宽度	Metal Blade: 255mm (10") Nylon Cutting Head: 430mm (17") Plastic Blade: 305mm (12")
No Load Speed (RPM) Kelajuan Tanpa Beban 回转速	Metal Blade / Plastic Blade (305mm): High: 0 - 7,000 Mid: 0 - 5,500 Low: 0 - 4,600 Nylon Cutting Head / Plastic Blade (255mm): High: 0 - 5,500 Mid: 0 - 5,000 Low: 0 - 4,600 M10 x 1.25LH
Spindle Size Saiz Spinde 主轴尺寸	M10 x 1.25LH
Dimensions (L x W x H) Dimensi 体积	1,815x396x266mm (71-1/2x15-5/8x10-1/2")
Net Weight Berat Bersih 净重	5.3 - 5.9kg (11.7 - 13.0lbs.)
Continuous Usage Time (approx.) Masa Penggunaan Berterusan 连续使用时间	Low: 32 min Med: 20 min High: 16 min with BL4050F (2 tooth Metal Blade)

UR008GM101 | UR008GZ01

Cordless Grass Trimmer
Pemotong Rumput Tanpa Kord
充电式割草机

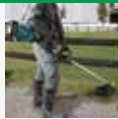

*Recommended batteries 2.5Ah, 4.0Ah, 5.0Ah

- Wet Guard/ IPX4-compatible; High water-resistance allows to operate the machine even if it is wet with water

Standard Equipment: Safety Goggles, Nylon Cutting Head, Accessory Bag, Hex Wrench

• GM101: 1x Fast Charger, 1x 4.0Ah Battery
• GZ01: Without Charger & Battery

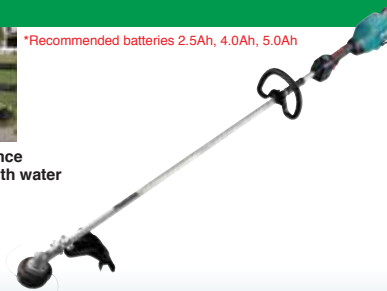

Max Output Keluaran Maksima 最大输出	1,000W
Cutting Width Lebar Keratan 切割宽度	Nylon Cutting Head: 430mm (17") Plastic Blade: 305mm (12")
No Load Speed (RPM) Kelajuan Tanpa Beban 回转速	Nylon Cutting Head: High: 0 - 5,000 Mid: 0 - 4,600 Low: 0 - 4,000 Plastic Blade (305mm): High: 0 - 6,000 Mid: 0 - 4,600 Low: 0 - 4,000 M10 x 1.25LH
Spindle Size Saiz Spinde 主轴尺寸	M10 x 1.25LH
Dimensions (L x W x H) Dimensi 体积	1,803x224x300mm (71x8-7/8x11-3/4")
Net Weight Berat Bersih 净重	5.0 - 5.7kg (11.0 - 12.6lbs.)
Continuous Usage Time (approx.) Masa Penggunaan Berterusan 连续使用时间	Low: 31 min Med: 19 min High: 13 min with BL4050F (Plastic Blade 305mm 12")

UR003GZ

Cordless Grass Trimmer
Pemotong Rumput Tanpa Kord
充电式割草机



*Recommended batteries 2.5Ah, 4.0Ah, 5.0Ah

- WetGuard; Excellent water-resistant performance

Standard Equipment: Safety Goggle, Blade Cover, Nylon Cutting Head (198892-0), Accessory Bag, Hex Wrench, Shoulder Belt

• GZ: Without Charger & Battery



Max Output Keluaran Maksima 最大输出	550W
Cutting Width Lebar Keratan 切割宽度	Metal Blade: 230mm (9") TCT Saw Blade: 255mm (10") Nylon Cutting Head: 350mm (13-3/4") Plastic Blade: 255mm (10")
No Load Speed (RPM) Kelajuan Tanpa Beban 回转速	High: 0 - 6,500 Mid: 5,300 Low: 3,500
Spindle Size Saiz Spinde 主轴尺寸	M10 x 1.25LH
Net Weight Berat Bersih 净重	3.9 - 4.5kg (8.6 - 9.8lbs.)
Work Amount (approx.) Jumlah Kerja 工作量	290m ² of area with BL4050F
Continuous Usage Time (approx.) Masa Penggunaan Berterusan 连续使用时间	Low: 92 min Med: 53 min High: 31 min with BL4050F (Nylon Cutting Head)

UC004GM101 | UC004GZ 350mm (14")

Cordless Chain Saw
Gergaji Rantai Tanpa Kord
充电式链锯



*Recommended batteries 2.5Ah, 4.0Ah

- High operability similar to engine chain saw

Standard Equipment: Saw Chain, Guide Bar, Guide Bar Cover, Oil supply, Round File, Box Wrench, Safety Goggles (195246-2)

• GM101: 1x Fast Charger, 1x 4.0Ah Battery
• GZ: Without Charger & Battery



Guide Bar Length Panjang Bar Panduan 导板长度	350mm (14")
Chain Pitch Kerapatan Rantai 链条齿距	3/8"
Chain Gauge Ketebalan Rantai 链条厚度	1.1mm (0.043")
Chain Speed Kelajuan Rantai 链条速度	0 - 24.8m/s (0 - 1,490m/min) (0 - 4,880FPM)
Oil Tank Capacity Tangki Minyak Pelincir 链油箱	200mL
Dimensions (L x W x H) Dimensi 体积	266x194x227mm (10-1/2x7-5/8x8-15/16")
Net Weight Berat Bersih 净重	3.8 - 4.7kg (8.4 - 10.4lbs.)
Work Amount (approx.) Jumlah Kerja 工作量	160 cuts with BL4040 & 90PX chain Cutting 100 x 100mm Cedar square timber

Cordless
Target Area 30x30cm

LED Flashlight
Lampu Suhu LED
LED 照明灯

Vacuum Cleaner
Pembersih Vakuum
吸尘器

Drilling / Fastening
Gergaji / Pengikat
钻孔 / 紧固

Impact Drilling / Demolition
Gergaji / Pemukul
冲击钻孔 / 拆除

Cutting
Pemotong
切割

Grinding / Sanding
Pengkilan / Poles
研磨 / 打磨

Sawing
Gergaji
锯切

Planing / Routing
Pengkilan / Tumpang
刨削 / 压板

Others
Lain-lain
其他

Outdoor Power Equipment
Alatan Kuasa Luar
园具 / 户外

Makita
— 1935 —



*Compatible batteries

UC016G Cordless Chain Saw

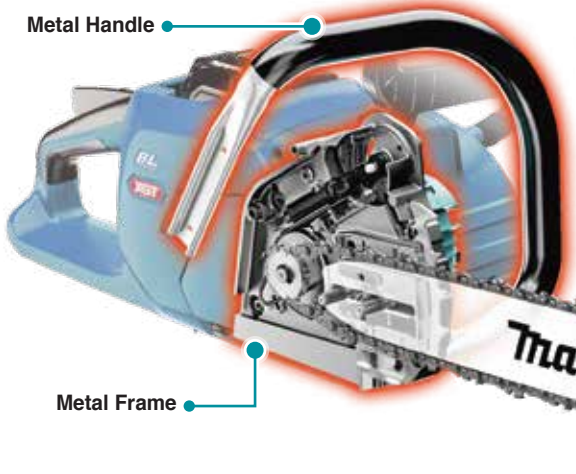

Work Amount
with BL4050F

ø300mm Cedar log
with 80TXL saw chain

35 cuts
(approx.)



Cordless
Target Model 40V Max

LED Flashlight
Lampu Suling LED
LED照灯

Vacuum Cleaner
Penyedot Vakuum
吸尘器

Drilling / Fastening
Dremel / Pengikat
钻 / 紧固

Impact Drilling / Demolition
Gardu / Perusak
钻工钻 / 拆墙加工

Cutting
Pemotong
切割

Grinding / Sanding
Pengam / Pasir
打磨 / 砂磨

Sawing
Gergaji
锯切

Planing / Routing
Pengam / Rintang
刨 / 雕刻

Others
Lain-lain
其他

Outdoor Power Equipment
Alat-alat Kerja Luar
园林-户外

Makita
1915



Slim body

Excellent tool balance



Metal spike bar



Metal chain catcher



Large oil tank cap
allows for easy chain oil filling



Variable speed trigger
switch



Tool-less chain adjustment
Easier saw chain tightening
Higher tightening torque



Main power switch
allows for easy chain oil filling

UC016GT101 | UC016GZ 400mm (16")

Cordless Chain Saw
Gergaji Rantai Tanpa Kord
充电式链锯



*Recommended batteries 5.0Ah

• Excellent cutting performance equivalent to 42cc class engine chain saws

Standard Equipment:
Saw Chain, Guide Bar, Guide Bar Cover, Wrench, Chain Oil, Round File, Safety Goggles (195246-2)

• GT101: 1x Fast Charger, 1x 5.0Ah Battery
• GZ: Without Charger & Battery



Max Output Keluaran Maksima 最大输出	1,600W
Guide Bar Length Panjang Bar Panduan 导板长度	400mm (16")
Chain Pitch Kerapatan Rantai 链条齿距	3/8"
Chain Gauge Ketebalan Rantai 链条厚度	1.1mm (0.043")
Chain Speed Kelajuan Rantai 链条速度	0 - 25.5m/s (0 - 1,530m/min) (0 - 5,020FPM)
Oil Tank Capacity Tangki Minyak Pelincir 链油箱	260mL
Dimensions (L x W x H) Dimensi 体积	445x234x275mm (17-1/2x9-1/4x10-7/8")
Net Weight Berat Bersih 净重	6.2 - 7.5kg (13.7 - 16.5lbs.)
Work Amount (approx.) Jumlah Kerja 工作量	35 cuts with BL4050F ø300mm Cedar log with 80TXL saw chain

UA004GM102 | UA004GZ01

Cordless Telescopic Pole Saw
Gergaji Rantai Teleskopik
Tanpa Kord
充电式无刷伸缩式高枝链锯



*Recommended batteries 4.0Ah, 5.0Ah

• High power BL motor delivers the same or higher operation efficiency than 35 mL class engine models

Standard Equipment:
Saw Chain, Guide Bar, Guide Bar Case, Wrench, Hex Wrench, Band Assembly, Round File & File Guide Set, Safety Goggles (195246-2), Chain Oil

• GM102: 1x Fast Charger, 1x 4.0Ah Battery
• GZ01: Without Charger & Battery

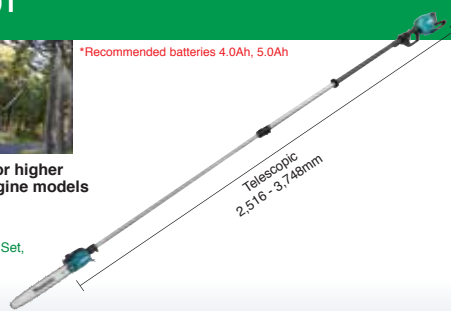

Max Output Keluaran Maksima 最大输出	1,500W
Guide Bar Length Panjang Bar Panduan 导板长度	300mm (12")
Saw Chain Rantai 链条	Gauge: 1.1 - 1.3mm (0.043 - 0.050") Pitch: 3/8"
Chain Speed Kelajuan Rantai 链条速度	0 - 20m/s (0 - 1,200m/min) (3,940FPM)
Oil Tank Capacity Tangki Minyak Pelincir 链油箱	160mL
Dimensions (L x W x H) Dimensi 体积	2,516-3,748x156x187mm (99-147-1/2x6-1/8x7-3/8")
Net Weight Berat Bersih 净重	7.8 - 9.1kg (17.2 - 20.1lbs.)
Work Amount (approx.) Jumlah Kerja 工作量	153 cuts with BL4040 100 x 100mm Cedar square timber

* All list price shown are for reference only (exclude SST).

* Semua harga yang ditunjukkan adalah untuk rujukan sahaja (tidak termasuk SST). 所有显示的建议零售价仅供参考 (不包括SST)。

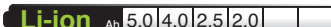

*Compatible batteries

UA003GM102 | UA003GZ01

Cordless Pole Saw

Gergaji Rantai Teleskopik
Tanpa Kord
充电式无刷高枝链锯

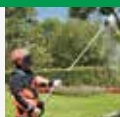

*Recommended batteries 4.0Ah, 5.0Ah

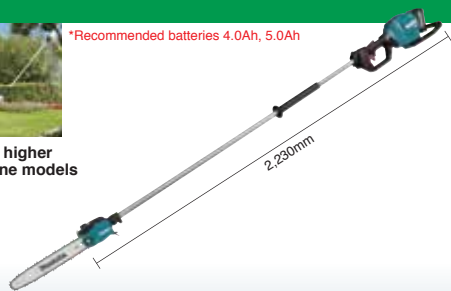

• High power BL motor delivers the same or higher operation efficiency than 35 mL class engine models

Standard Equipment:

Saw Chain, Guide Bar, Guide Bar Case, Wrench, Band Assembly, Round File & File Guide Set, Safety Goggles (195246-2), Chain Oil

• GM102: 1x Fast Charger, 1x 4.0Ah Battery
• GZ01: Without Charger & Battery



Max Output Keluaran Maksima 最大输出	1,500W
Guide Bar Length Panjang Bar Panduan 导板长度	300mm (12")
Saw Chain Rantai 链条	Gauge: 1.1 - 1.3mm (0.043 - 0.050") Pitch: 3/8"
Chain Speed Kelajuan Rantai 链条速度	0 - 20m/s (0 - 1,200m/min) (3,940FPM)
Oil Tank Capacity Tangki Minyak Pelincir 链油箱	160mL
Dimensions (L x W x H) Dimensi 体积	2,230x156x187mm (88x6-1/8x7-3/8")
Net Weight Berat Bersih 淨重	6.1 - 7.4kg (13.4 - 16.3lbs.)
Work Amount (approx.) Jumlah Kerja 工作量	153 cuts with BL4040 100 x 100mm Cedar square timber

**UX01G
Cordless Multi Function
Power Head**

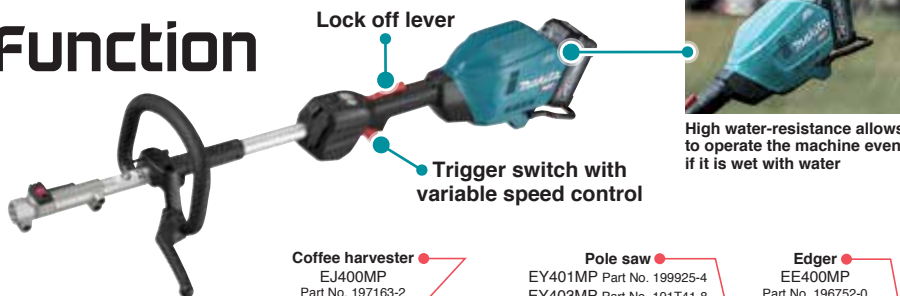

High water-resistance allows to operate the machine even if it is wet with water

<p>Brushcutter *EM400MP Part No. 195657-1 *EM403MP Part No. 198760-7 *UX01G / DUX60 only</p> <p>Grass Trimmer EM408MP Part No. 191N34-9 EM409MP Part No. 191N46-2</p> <p>Rotary scissors EM407MP Part No.191M57-1</p>	<p>Power brush BR400MP Part No. 199323-2</p> <p>Power sweep SW400MP Part No. 199344-4</p> <p>Ground trimmer EN420MP (Angle adjustable) Part No. 198061-3</p> <p>Pole hedge trimmer EN401MP (Angle adjustable) Part No. 196341-1</p>	<p>Coffee harvester EJ400MP Part No. 197163-2</p> <p>Hedge trimmer EN410MP (Straight) Part No. 197742-6</p> <p>Shaft extension attachment LE400MP Part No. 191E23-0 Length: 1,080mm (42-1/2") for Pole saw, Pole hedge trimmer and Coffee harvester</p>	<p>Pole saw EY401MP Part No. 199925-4 EY403MP Part No. 191T41-8</p> <p>Cultivator KR400MP Part No. 195716-1 KR401MP Part No. 199185-8</p>	<p>Edger EE400MP Part No. 196752-0</p>
--	---	--	---	---



UX01GZ

**Cordless Multi Function
Power Head**

Powerhead Pelbagai Fungsi
Tanpa Kord
充电式多功能动力机



*Recommended batteries 2.5Ah, 4.0Ah, 5.0Ah



Standard Equipment: Shoulder Harness, Hex Wrench, Safety Goggles (195246-2), Accessory Bag

• GZ: Without Charger & Battery



Max Output Keluaran Maksima 最大输出	1,000W
No Load Speed (RPM) Kelajuan Tanpa Beban 回转数	High: 0 - 9,700 Med: 0 - 8,200 Low: 0 - 5,700
Dimensions (L x W x H) Dimensi 体积	1,001x320x209mm (39-1/2x12-5/8x8-1/4")
Net Weight Berat Bersih 淨重	4.2 - 4.8kg (9.3 - 10.6lbs.)



VIDEO CLIP
Models and specs may vary by country

* All list price shown are for reference only (exclude SST).

* Semua harga yang ditunjukkan adalah untuk rujukan sahaja (tidak termasuk SST). 所有显示的建议零售价仅供参考 (不包括SST)。

Cordless
Targeted Jobs

LED Flashlight
Lampu Suli LED
LED 闪光灯

Vacuum Cleaner
Pembersih Vakuum
吸尘器

Drilling / Fastening
Gergaji / Pasak
电钻 / 螺絲

Impact Drilling / Demolition
Gergaji / Pasak
电钻 / 螺絲

Cutting
Pemotong
切割机

Grinding / Sanding
Pergasi / Pasak
砂光机 / 螺絲

Sawing
Gergaji
电锯

Planing / Routing
Pergasi / Pasak
砂光机 / 螺絲

Others
Lain-lain
其他

Outdoor Power Equipment
Alatan Kuat Luar
户外动力工具





*Compatible batteries

DG001GZ05

Cordless Earth Auger
Mesin Gerudi Tanah Tanpa Kord
充电式弯角度地钻头



*Recommended batteries 2.5Ah, 4.0Ah, 5.0Ah

- High power similar to AC tool



Standard Equipment:
Chuck Key S-13 (763251-3), Chuck Key Holder,
Handle Set (191P11-3), Hex Wrench,
Adapter A (327684-2), Adapter D (327687-6)

- GZ05: Without Charger & Battery



Capacity Kapasiti 能力	Sandy Soil: 200mm Clay Soil: 150mm
Chuck Capacity Kapasiti Chuck 夹头能力	2 - 13mm (1/16 - 1/2")
No Load Speed (RPM) Kelajuan Tanpa Beban 回转数	High: 0 - 1,500 Low: 0 - 400
Max Fastening Torque Pemutaran Tenaga Maksimum 最大扭矩	High: 55N-m (487in.lbs.) Low: 136N-m (1,210in.lbs.)
Dimensions (L x W x H) Dimensi 体积	836x605x199mm (33x23-3/4x7-7/8")
Net Weight Berat Bersih 淨重	7.2 - 8.1kg (15.9 - 17.9lbs.)
Work Amount (approx.) Jumlah Kerja 工作量	100 holes with BL4040 ø150mm, 600mm depth (Low Speed)

UH006GM201 | UH006GZ 600mm (23-5/8")

Cordless Hedge Trimmer
Pemangkas Tanaman Pagar
Tanpa Kord
充电式篱笆树剪



*Recommended batteries 2.0Ah, 2.5Ah, 4.0Ah

- Reliable cutting performance like engine/AC hedge trimmers
- Suitable for rough cutting

Standard Equipment:
Blade Cover, Safety Goggles (195246-2)

- GM201: 1x Fast Charger, 2x 4.0Ah Battery
- GZ: Without Charger & Battery



Blade Length Panjang Bilah 刀片长度	600mm (23-5/8")
Strokes Per Minute (SPM) Kelajuan Strok 冲程速度	High: 4,000 Mid: 3,000 Low: 2,000
Tooth Spacing Selang Gigi 牙齿间隔	38mm (1-1/2")
Max Cutting Capacity Kapasiti Pemotongan Maksimum 最大切割能力	25.0mm (1")
Dimensions (L x W x H) Dimensi 体积	1,123x223x191mm (44-1/2x8-3/4x7-1/2")
Net Weight Berat Bersih 淨重	4.4 - 5.0kg (9.7 - 11.0lbs.)
Continuous Usage Time (approx.) Masa Penggunaan Berterusan 连续使用时间	Low: 195 min Med: 110 min High: 65 min with BL4040

UH004GM201 | UH004GZ 600mm (23-5/8")

Cordless Hedge Trimmer
Pemangkas Tanaman Pagar
Tanpa Kord
充电式篱笆树剪



*Recommended batteries 2.0Ah, 2.5Ah, 4.0Ah

- Ideal for smoothly and efficiently trimming twigs, thin branches or dense hedges
- Suitable for trimming

Standard Equipment:
Blade Cover, Safety Goggles (195246-2)

- GM201: 1x Fast Charger, 2x 4.0Ah Battery
- GZ: Without Charger & Battery



Blade Length Panjang Bilah 刀片长度	600mm (23-5/8")
Strokes Per Minute (SPM) Kelajuan Strok 冲程速度	High: 5,000 Mid: 3,600 Low: 2,000
Tooth Spacing Selang Gigi 牙齿间隔	35mm (1-3/8")
Max Cutting Capacity Kapasiti Pemotongan Maksimum 最大切割能力	23.5mm (15/16")
Dimensions (L x W x H) Dimensi 体积	1,120x223x191mm (44x8-3/4x7-1/2")
Net Weight Berat Bersih 淨重	4.3 - 4.9kg (9.5 - 10.8lbs.)
Continuous Usage Time (approx.) Masa Penggunaan Berterusan 连续使用时间	Low: 370 min Med: 160 min High: 85 min with BL4040

UH014GM101 | UH014GZ 750mm (29-1/2")

Cordless Hedge Trimmer
Pemangkas Tanaman Pagar
Tanpa Kord
充电式篱笆树剪



*Recommended batteries 2.0Ah, 2.5Ah, 4.0Ah

- Increased cutting speed and torque for smooth and efficient cutting similar to those of engine hedge trimmers

Standard Equipment: Blade Cover, Chip Receiver

- GM101: 1x Fast Charger, 1x 4.0Ah Battery
- GZ: Without Charger & Battery



Blade Length Panjang Bilah 刀片长度	750mm (29-1/2")
Strokes Per Minute (SPM) Kelajuan Strok 冲程速度	High: 5,000 Mid: 3,600 Low: 2,000
Tooth Spacing Selang Gigi 牙齿间隔	35mm (1-3/8")
Max Cutting Capacity Kapasiti Pemotongan Maksimum 最大切割能力	18mm (11/16")
Dimensions (L x W x H) Dimensi 体积	1,225x270x135mm (48-1/4x10-5/8x5-5/16")
Net Weight Berat Bersih 淨重	4.0 - 4.7kg (8.8 - 10.4lbs.)
Continuous Usage Time (approx.) Masa Penggunaan Berterusan 连续使用时间	Low: 390 min Med: 160 min High: 85 min with BL4040

UB001GM101 | UB001GZ

Cordless Blower
Mesin Penghembus Angin
Tanpa Kord
充电式吹风机



*Recommended batteries 4.0Ah, 5.0Ah

- Compact and lightweight for single handed operation

Standard Equipment: Shoulder Belt (166094-6),
End Nozzle (191P97-7), Adapter Pipe (191L96-5),
Flat Nozzle (197889-6), Extension nozzle (197888-8)

- GM101: 1x Fast Charger, 1x 4.0Ah Battery
- GZ: Without Charger & Battery









Max Air Volume Isipadu Angin Maksimum 最大风量	Cruise Control Mode: 0 - 13.5 m³/min Boost Mode: 16.0 m³/min
Max Air Velocity Velositi Angin Maksimum 最大风速	Cruise Control Mode: 53 m/s Boost Mode: 64 m/s
Blowing Force Kekuatan Tiupan 强大的吹力	Cruise Control Mode: 0 - 12 N Boost Mode: 17 N
No Load Speed (RPM) Kelajuan Tanpa Beban 回转数	Cruise Control Mode: 0 - 20,000 Boost Mode: 23,000
Dimensions (L x W x H) Dimensi 体积	850 - 950x167x297mm (33-1/2-37-1/2x6-9/16x11-3/4")
Net Weight Berat Bersih 淨重	3.1 - 3.9kg (6.8 - 8.6lbs.)
Continuous Usage Time (approx.) Masa Penggunaan Berterusan 连续使用时间	Boost mode: 6 min with BL4040

* All list price shown are for reference only (exclude SST).

* Semua harga yang ditunjukkan adalah untuk rujukan sahaja (tidak termasuk SST). 所有显示的建议零售价仅供参考 (不包括SST)。

Cordless Target Kord 无绳式
LED Flashlight Lampu Suluh LED LED 手电筒
Vacuum Cleaner Pemilauhi Vakuim 吸尘器
Drilling / Fastening Druai / Pengikat 钻 / 螺絲
Impact Drilling / Demolition Druai / Penumbuh 起工钻 / 拆工
Cutting Pemangkas 切割
Grinding / Sanding Pengisar / Pechin 磨 / 砂
Sawing Gergaji 电锯
Planing / Routing Pengisar / Tangkapan 刨 / 磨
Others Lain-lain 其他
Outdoor Power Equipment Alatan Kord Luar 户外动力工具
Makita

 	Recommended Batteries Chart				⊙ Excellent	○ Good	✗ Not Applicable
	 5.0Ah BL4050F	 4.0Ah BL4040	 2.5Ah BL4025	 2.0Ah BL4020			
Model							
AS001G	○	⊙	⊙	⊙			⊙
CE001G		○			✗		✗
CL001G	○	⊙	⊙	⊙			⊙
CL002G	○	⊙	⊙	⊙			⊙
CS002G	⊙	⊙	⊙	⊙			○
DA001G	⊙	⊙	⊙	⊙			○
DF001G	⊙	⊙	⊙	⊙			⊙
DF002G	○	⊙	⊙	⊙			⊙
DG001G	⊙	⊙	⊙	⊙			○
FN001G	○	○	⊙	⊙			⊙
GA003G	⊙	⊙	⊙	⊙			○
GA005G	⊙	⊙	⊙	⊙			○
GA011G	⊙	⊙	⊙	⊙			○
GA013G	⊙	⊙	⊙	⊙			○
GA021G	⊙	⊙	⊙	⊙			○
GA023G	⊙	⊙	⊙	⊙			○
GA027G	⊙	⊙	⊙	⊙			○
GA029G	⊙	⊙	⊙	⊙			○
GA035G	⊙	⊙	⊙	⊙			○
GA036G	⊙	⊙	⊙	⊙			○
GA037G	⊙	○	○	○			✗
GA038G	⊙	○	○	○			✗
GA042G	⊙	⊙	⊙	⊙			○
GA044G	⊙	⊙	⊙	⊙			○
HM001G	⊙	⊙	⊙	○			○
HM002G	⊙	⊙	⊙	○			○
HP001G	⊙	⊙	⊙	⊙			⊙
HP002G	○	⊙	⊙	⊙			⊙
HR001G	○	⊙	⊙	⊙			⊙
HR002G	○	⊙	⊙	⊙			⊙
HR003G	○	⊙	⊙	⊙			⊙
HR005G	⊙	⊙	○	○			○
HR006G	⊙	⊙	⊙	○			○
HR007G	○	⊙	⊙	⊙			⊙
HS004G	⊙	⊙	○	○			○
HS009G	⊙	○	○	○			○
HS011G	⊙	○	○	○			○
JR001G	○	⊙	⊙	⊙			⊙
JR002G	⊙	⊙	⊙	⊙			⊙
KP001G	○	⊙	⊙	⊙			⊙
LS002G	⊙	⊙	⊙	⊙			○
LS003G	⊙	⊙	○	○			○
LS004G	⊙	⊙	○	○			○
ML001G	⊙	⊙	⊙	⊙			⊙
ML002G	✗	⊙	⊙	⊙			⊙
ML003G	⊙	⊙	⊙	⊙			⊙
ML006G	⊙	⊙	⊙	⊙			⊙
ML007G	⊙	⊙	⊙	⊙			⊙
MP001G	⊙	⊙	⊙	⊙			⊙
PB002G	○	⊙	⊙	⊙			⊙
PT001G	○	○	⊙	⊙			⊙
RT001G	✗	⊙	⊙	⊙			⊙
SP001G	⊙	⊙	⊙	⊙			○
TD001G	○	⊙	⊙	⊙			⊙
TW001G	○	⊙	⊙	⊙			⊙
TW005G	○	⊙	⊙	⊙			⊙
TW007G	○	⊙	⊙	⊙			⊙
TW008G	○	⊙	⊙	⊙			⊙
UA003G	⊙	⊙	○	○			○
UA004G	⊙	⊙	○	○			○
UB001G	⊙	⊙	○	○			○
UC004G	○	⊙	⊙	⊙			○
UC016G	⊙	○	○	✗			✗
UH004G	○	⊙	⊙	⊙			⊙
UH006G	○	⊙	⊙	⊙			⊙
UH014G	○	⊙	⊙	⊙			⊙
UR003G	⊙	⊙	⊙	⊙			○
UR007G	⊙	⊙	⊙	⊙			○
UR008G	⊙	⊙	⊙	⊙			○
UR012G	⊙	○	○	○			○
UX01G	⊙	⊙	⊙	⊙			○
VC001GL	⊙	⊙	○	○			○
VC002GL	⊙	⊙	○	○			○
VC005GL	⊙	⊙	○	○			○

* All list price shown are for reference only (exclude SST).

☐ Suitable for usage

* Semua harga yang ditunjukkan adalah untuk rujukan sahaja (tidak termasuk SST). 所有显示的建议零售价仅供参考 (不包括SST)。

Cordless
Target Tools & Tools

LED Flashlight
Lampu Saku LED
LED手电筒

Vacuum Cleaner
Pembersih Vakuum
吸尘器

Drilling / Fastening
Gergaji / Pengikat
钻孔 / 紧固

Impact Drilling / Demolition
Gergaji / Pemecah
石工钻孔 / 砸墙施工

Cutting
Pemotong
切割机

Grinding / Sanding
Pengkil / Pasir
研磨 / 砂磨

Sawing
Gergaji
锯切

Planing / Routing
Pergeseran / Tergeseran
刨削 / 压削

Others
Lain-lain
其他

Outdoor Power Equipment
Alatan Kuasa Luar
园机/户外

Thakita
— 100% —



Comfortable For Long Hours Operation



ENERGY CAPACITY COMPARISON

PDC1200



1 : 22 Ratio

18V 3.0Ah Battery



Portable Power Pack	Adapter set
<p>PDC1200</p> <p>Equipped with built-in battery cells</p> <p>IPX4 Water Resistance</p> 	<p>PDC1200A01 included</p> <ul style="list-style-type: none"> - 18Vx2 Adapter (191J51-5) - DC4001 Battery Charger Set (191L01-2) - Harness Assembly (127668-8)  <p>Optional 40Vmax Adapter Set (191N62-4)</p>
Capacity Kapasiti 能力	33.5Ah
Energy Capacity Keupayaan Tenaga 能量容量	1,206Wh
Power Supply Cord Kord Bekalan Kuasa 电源线	Battery Side: 1.1m (3.6ft) Adapter Side: 0.6m (2.0ft)

Portable Power Pack	Adapter set
<p>PDC01</p> <p>Powered by up to four 18V LXT batteries</p> <p>IPX4 Water Resistance</p> 	<p>1 PDC01 (191A62-6) included</p> <ul style="list-style-type: none"> - 18V Adapter (191J50-7) - 18Vx2 Adapter (191J51-5) - Harness Assembly  <p>2 PDC01 (191A67-6) included</p> <ul style="list-style-type: none"> - 18Vx2 Adapter (191J51-5) - Harness Assembly  <p>Optional 40Vmax Adapter Set (191N62-4)</p>
Capacity Kapasiti 能力	18V x2 : 12 Ah (with BL1860B x4) 18V : 24 Ah (with BL1860B x4)
Energy Capacity Keupayaan Tenaga 能量容量	432Wh (BL1860Bx4)
Power Supply Cord Kord Bekalan Kuasa 电源线	1.7m (5.6 ft)

UR201CZ

Battery Powered Grass Trimmer
Pemotong Rumput Berkuasa Bateri
充电式割草机



- 1.0kW max output power similar to 30mL class engine grass trimmers

Standard Equipment: Safety Goggles (195246-2), Metal Blade, Nylon Cutting Head, Plastic Blade, Blade Cover (for Metal Blade), Accessory Bag, Hex Wrench, Box Wrench, Band Assembly

• CZ: Without Charger & Battery

BL MOTOR XPT ADT AFT

Max Output Keluaran Maksima 最大输出	1,000W
Cutting Width Lebar Keratan 切割宽度	Metal Blade / Plastic Blade: 255mm (10") Nylon Cutting Head: 430mm (17")
No Load Speed (RPM) Kelajuan Tanpa Beban 回转数	Metal Blade (3 / 2 / 1): 0 - 7,000 / 0 - 5,500 / 0 - 4,600 Nylon Cutting Head (3 / 2 / 1): 0 - 5,500 / 0 - 5,000 / 0 - 4,600 Plastic Blade (305mm) (3 / 2 / 1): 0 - 7,000 / 0 - 5,500 / 0 - 4,600 Plastic Blade (255mm) (3 / 2 / 1): 0 - 5,500 / 0 - 5,000 / 0 - 4,600
Spindle Size Saiz Spindel 主轴尺寸	M10 x 1.25LH
Dimensions (L x W x H) Dimensi 体积	1,795x400x269mm (70-1/2"x15-3/4"x10-5/8")
Net Weight Berat Bersih 净重	4.7kg (10.4lbs.)
Continuous Usage Time (approx.) Masa Penggunaan Berterusan 连续使用时间	Low: 76 min with PDC01 (BL1860B x4) Metal blade with load

LM001CZ

Battery Powered Lawn Mower
Mesin Pemotong Rumput Tanpa Kord
充电式手推割草机



- Long continuous operation

Standard Equipment: Blade, Mulch Plug, Side Discharge Mouth, Box Wrench, Rod

• CZ: Without Charger & Battery

BL MOTOR XPT SOFT NOLOAD

Max Output Keluaran Maksima 最大输出	1,600W
Blade Hole Diameter Diameter lubang bilah 叶片孔直径	10.0mm (3/8")
Cutting Width Lebar Keratan 切割宽度	534mm (21")
Cutting Height Ketinggian Pemotongan 切割高度	20 - 100mm (13/16" - 3-15/16")
Grass box capacity Kapasiti Kotak Rumput 草箱容量	70L
No Load Speed (RPM) Kelajuan Tanpa Beban 回转数	2,300 - 2,800
Dimensions (L x W x H) Dimensi 体积	1,630-1,715x590x990-1,095mm (64"-67-1/2"x23-1/4"x39"-43")
Net Weight Berat Bersih 净重	39.0 - 42.8kg (86.0 - 94.4lbs.)
Continuous Usage Time (approx.) Masa Penggunaan Berterusan 连续使用时间	40 min (self-propelled) 50 min (push-drive) with PDC01 (BL1860B x4), 2-Tooth Blade 120 min (self-propelled) 150 min (push-drive) with PDC1200, 2-Tooth Blade

UB001CZ

Battery Powered Blower
Mesin Penghembus Angin Berkuasa Bateri
充电式吹风机



- In Boost mode, 20N max blowing force is always available

Standard Equipment: Shoulder Belt (191J48-4), End Nozzle (412758-3)

• CZ: Without Charger & Battery

BL MOTOR

Max Air Volume Isipadu Angin Maksimum 最大风量	Boost Mode: 17.6m³/min Cruise Control Mode: 0 - 15.0m³/min
Max Air Velocity Velositi Angin Maksimum 最大风速	Boost Mode: 70m/s Cruise Control Mode: 0 - 60m/s
Avg. Air Velocity Kelajuan Angin Purata 平均风速	Boost Mode: 58m/s Cruise Control Mode: 0 - 50m/s
No Load Speed (RPM) Kelajuan Tanpa Beban 回转数	Boost Mode: 24,000 Cruise Control Mode: 0 - 21,000
Dimensions (L x W x H) Dimensi 体积	960 - 1,060 x 295 x 180mm (37-3/4-41-3/4x11-1/2x7")
Net Weight Berat Bersih 净重	2.6 - 2.9kg (5.7 - 6.5lbs.)
Continuous Usage Time (approx.) Masa Penggunaan Berterusan 连续使用时间	Boost Mode: 17 min Cruise Control Mode: 28 min with PDC01 BL1860B x4 Boost Mode: 60 min Cruise Control Mode: 90 min with PDC1200

* All list price shown are for reference only (exclude SST).

* Semua harga yang ditunjukkan adalah untuk rujukan sahaja (tidak termasuk SST). 所有显示的建议零售价仅供参考 (不包括SST)。

Cordless Target Kord 无绳式
LED Flashlight Lampu Suluh LED LED 照明灯
Vacuum Cleaner Pembersih Vakuum 吸尘器
Drilling / Fastening Dremel / Pengikat 钻 / 紧固
Impact Drilling / Demolition Ganda / Penumbuh 钻 / 拆
Cutting Pemotong 切割
Grinding / Sanding Pengisar / Polish 研磨 / 打磨
Sawing Ganda 锯切
Planing / Routing Pengisar / Tangkai 刨 / 磨
Others Lain-lain 其他
Outdoor Power Equipment Alatan Kuasa Luar 户外动力设备



64Vmax

Li-ion Ah 4.0

LM002J Cordless Lawn Mower

64V Li-ion max



BL6440



Cutting width
534mm

Higher mowing performance



The blade is designed so that it tilts towards the front side of the mower when attached, preventing double-cutting for reduced current consumption



Optimum blade design for less rotational speed reduction of the blade



LM002JM101 530mm (21")

Cordless Lawn Mower
Mesin Pemotong Rumput Tanpa Kord
充电式手推割草机



- High power cordless lawn mower powered by 64Vmax Li-Ion battery

Standard Equipment:
Blade, Mulching Plug, Socket Wrench, Rod

• JM101: 1x Charger, 1x 4.0Ah Battery



Max Output Keluaran Maksima 最大输出	2,300W
Cutting Width Lebar Keratan 切割宽度	534mm (21")
Cutting Height Ketinggian Pemotongan 切割高度	20 - 100mm (13/16 - 3-15/16")
Grass Box Capacity Kapasiti Kotak Rumput 草箱容量	70L
No Load Speed (RPM) Kelajuan Tanpa Beban 回转数	Standard Mode: 2,800 Low Noise Mode: 2,300
Dimensions (L x W x H) Dimensi 体积	1,710-1,800x585x950-1,090mm (67-1/2-71x23x37-1/2-43")
Net Weight Berat Bersih 净重	25.7 - 27.6kg (56.7 - 60.8lbs.)
Continuous Usage Time (approx.) Masa Penggunaan Berterusan 连续使用时间	Moving Area 1,600m ² or 34 min with BL6440

* All list price shown are for reference only (exclude SST).

* Semua harga yang ditunjukkan adalah untuk rujukan sahaja (tidak termasuk SST). 所有显示的建议零售价仅供参考 (不包括SST)。

Cordless
Tanpa Kord / 无线

LED Flashlight
Lampu Suluh LED / LED 闪光灯

Vacuum Cleaner
Pembersih Vakuum / 吸尘器

Drilling / Fastening
Ganda / Pengikat / 钻孔 / 紧固

Impact Drilling / Demolition
Ganda / Pembongkaran / 冲击钻孔 / 拆除

Cutting
Pemotong / 切割

Grinding / Sanding
Pengiraan / Poles / 打磨 / 砂磨

Sawing
Gergaji / 锯切

Planing / Routing
Pengiraan / Tangkapan / 刨平 / 嵌条

Others
Lain-lain / 其他

Outdoor Power Equipment
Alatan Kuasa Luar / 户外动力设备

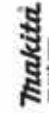



Li-ion Ah 6.0 5.0 4.0 3.0 2.0 1.5

DHR400 Cordless Rotary Hammer

Accessories (Optional)



DHR400ZKN 40mm (1-9/16")

Cordless Rotary Hammer

Tukul Putar Tanpa Kord
充电式电钻



- High power and excellent performance

Standard Equipment: Side Handle, Side Grip, Depth Gauge, Bit Grease (194683-7), Cleaning Cloth

- ZKN: With Carrying Case, Without Charger & Battery

Impact Energy Kekuatan Impak 单次最大冲击力	EPTA-Procedure 05/2009: 8.0J Our experimental conditions: 11.4J
Capacity Kapasiti 能力	Concrete (TCT Bit): 40mm (1-9/16") Concrete (Core Bit): 105mm (4-1/8")
Impacts Per Minute (IPM) Impak Per Minit 冲击数	1,450 - 2,900
No Load Speed (RPM) Kelajuan Tanpa Beban 回转数	250 - 500
Dimensions (L x W x H) Dimensi 体积	473x120x285mm (18-5/8"x4-3/4"x11-1/4")
Net Weight Berat Bersih 净重	7.3 - 8.1kg (16.1 - 17.9lbs.)
Work Amount (approx.) Jumlah Kerja 工作量	25 holes with BL1850B x2 Concrete Grade 40 D18mm x 140mm Depth



DHR282 Cordless Combination Hammer

Accessories (Optional)



DHR282PT2J | DHR282Z 28mm (1-1/8")

Cordless Combination Hammer

Tukul Kombinasi Tanpa Kord
充电式冲击电钻电锤

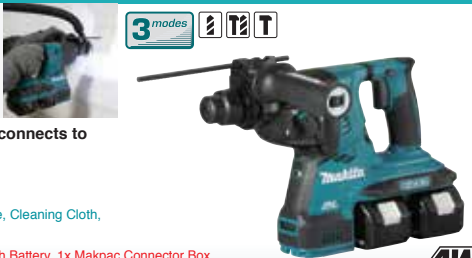

- Auto-start Wireless System (AWS) connects to vacuum cleaner with Bluetooth

Standard Equipment: Side Grip, Depth Gauge, Cleaning Cloth, Bit Grease (194683-7)

- PT2J: 1x Two Port Multi Fast Charger, 2x 5.0Ah Battery, 1x Makpac Connector Box
- Z: Without Charger, Battery & Carrying Case



Impact Energy Kekuatan Impak 单次最大冲击力	EPTA-Procedure 05/2009: 2.8J Our experimental conditions: 3.2J
Capacity Kapasiti 能力	Concrete: 28mm (1-1/8") Steel: 13mm (1/2") Wood: 32mm (1-1/4") Core Bit: 54mm (2-1/8") Diamond Core Bit (Dry Type): 65mm (2-9/16")
Impacts Per Minute (IPM) Impak Per Minit 冲击数	0 - 5,000
No Load Speed (RPM) Kelajuan Tanpa Beban 回转数	0 - 980
Chuck Capacity Kapasiti Chuck 夹头能力	1.5 - 13mm (1/16 - 1/2")
Max Output Keluasan Maksima 最大输出	680W
Dimensions (L x W x H) Dimensi 体积	373x134x232mm (14-3/4"x5-1/4"x9-1/8")
Net Weight Berat Bersih 净重	3.9 - 5.0 kg (8.6 - 11.0 lbs.)
Work Amount (approx.) Jumlah Kerja 工作量	187 holes with BL1850B x2 Concrete Grade 40 D10.5mm x 60mm Depth

DHR280PT2J | DHR280Z 28mm (1-1/8")

Cordless Combination Hammer

Tukul Kombinasi Tanpa Kord
充电式冲击电钻电锤

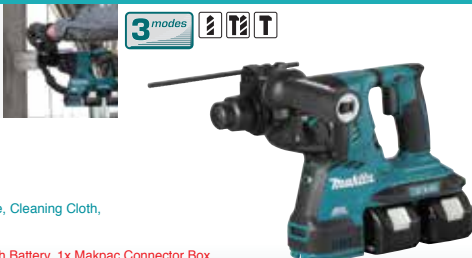

- High Power and Low Vibration

Standard Equipment: Side Grip, Depth Gauge, Cleaning Cloth, Bit Grease (194683-7)

- PT2J: 1x Two Port Multi Fast Charger, 2x 5.0Ah Battery, 1x Makpac Connector Box
- Z: Without Charger, Battery & Carrying Case



Impact Energy Kekuatan Impak 单次最大冲击力	EPTA-Procedure 05/2009: 2.8J Our experimental conditions: 3.2J
Capacity Kapasiti 能力	Concrete: 28mm (1-1/8") Steel: 13mm (1/2") Wood: 32mm (1-1/4") Core Bit: 54mm (2-1/8") Diamond Core Bit (Dry Type): 65mm (2-9/16")
Impacts Per Minute (IPM) Impak Per Minit 冲击数	0 - 5,000
No Load Speed (RPM) Kelajuan Tanpa Beban 回转数	0 - 980
Chuck Capacity Kapasiti Chuck 夹头能力	1.5 - 13mm (1/16 - 1/2")
Max Output Keluasan Maksima 最大输出	680W
Dimensions (L x W x H) Dimensi 体积	373x134x232mm (14-3/4"x5-1/4"x9-1/8")
Net Weight Berat Bersih 净重	3.9 - 4.9 kg (8.6 - 10.8 lbs.)
Work Amount (approx.) Jumlah Kerja 工作量	187 holes with BL1850B x2 Concrete Grade 40 D10.5mm x 60mm Depth

* All list price shown are for reference only (exclude SST).

* Semua harga yang ditunjukkan adalah untuk rujukan sahaja (tidak termasuk SST). 所有显示的建议零售价仅供参考 (不包括SST)。

Cordless Target Model 充电式

LED Flashlight Lampu Suluhi LED LED 照明灯

Vacuum Cleaner Pembersih Vakuum 吸尘器

Drilling / Fastening Gantol / Pengikat 钻式 / 紧固

Impact Drilling / Demolition Gantol / Pemusnah 钻式 / 拆除加工

Cutting Pemotong 切割

Grinding / Sanding Pengisar / Piskin 磨削 / 打磨

Sawing Cergas 切割

Planing / Routing Pengisar / Tangkap 磨削 / 雕刻

Others Lain-lain 其他

Outdoor Power Equipment Alatan Kerja Luar 户外工具

Makita



Li-ion Ah 6.0 5.0 4.0 3.0 2.0 1.5

DHR263PM4 | DHR263Z 26mm (1") 442mm

Cordless Combination Hammer

Tukul Kombinasi Tanpa Kord
充电式冲击钻锤



- 3-Mode operation for Rotation Only, Hammering with Rotation or Hammering Only

Standard Equipment: Side Grip, Depth Gauge, Cleaning Cloth, Bit Grease (194683-7)

- PM4: 1x Two Port Multi Fast Charger, 4x 4.0Ah Battery, 1x Tool Bag
- RF4: 1x Rapid Charger, 4x 3.0Ah Battery, 1x Carrying Case
- Z: Without Charger, Battery & Carrying Case



Impact Energy Kekuatan Impak 单次最大冲击力	EPTA-Procedure 05/2009: 2.5J Our experimental conditions: 3.0J
Capacity Kapasiti 能力	Concrete: 26mm (1") Steel: 13mm (1/2") Wood: 32 mm (1-1/4")
Impacts Per Minute (IPM) Impak Per Minit 冲击数	0 - 5,000
No Load Speed (RPM) Kelajuan Tanpa Beban 回转数	0 - 1,250
Dimensions (L x W x H) Dimensi 体积	350x116x232mm (13-3/4"x4-9/16"x9-1/8")
Net Weight Berat Bersih 净重	4.1 - 5.1kg (9.0 - 11.3lbs)
Work Amount (approx.) Jumlah Kerja 工作量	133 holes with BL1850B x2 Concrete Grade 40 D10.5mm x 60mm Depth

DDA460ZK 13mm (1/2")

Cordless Angle Drill
Gerudi Sudut Tanpa Kord
充电式角向电钻



- Powerful drilling even large diameter holes

Standard Equipment: Chuck Key, Hex Wrench, Side Grip

- ZK: With Carrying Case, Without Charger & Battery



Capacity Kapasiti 能力	Steel: 13mm (1/2") Wood (Self-Feed Bit) Hi: 65mm (2-9/16") Wood (Self-Feed Bit) Lo: 118mm (4-5/8") Wood (Hole Saw) Hi: 105mm (4-1/8") Wood (Hole Saw) Lo: 159mm (6-1/4") Wood (Auger-Bit): 50mm (2")
No Load Speed (RPM) Kelajuan Tanpa Beban 回转数	High: 0 - 1,400 Low: 0 - 350
Max Fastening Torque Tenaga Pemutaran Pengancing Maksimum 最大紧固扭力	High: 48N-m (430 in.lbs.) Low: 136N-m (1,210 in.lbs.)
Max Output Keluaran Maksima 最大输出	1,350 W
Dimensions (L x W x H) Dimensi 体积	538x128x223mm (21-1/4"x5"x8-3/4")
Net Weight Berat Bersih 净重	5.7 - 6.4kg (12.6 - 14.0lbs.)
Work Amount (approx.) Jumlah Kerja 工作量	80 holes with BL1850B x2 2 Layered SPF

DWT310
Cordless Shear Wrench

Accessories (Optional)

Sleeve size reference table
*Type F (for HEXA TECH (GFD France))

Bolt Size	Outer sleeve			Inner sleeve	
	Hex Size	L (mm)	Part No.	L (mm)	Part No.
M16	27	35	764362-7	36	764416-0
M20	32	37	764361-9	38	764417-8
M20	32	37	764361-9	38	*764422-5
M22, 7/8"	36 1-7/16"	39	153909-6	39	764418-6
M22, 7/8"	36 1-7/16"	85	764364-3	85	764352-0
M22, 7/8"	36 1-7/16"	170	764365-1	170	764354-6



DWT310ZK M20 (3/4"), M22 (7/8")

Cordless Shear Wrench
Perengkuh Ricih Tanpa Kord
充电式扭断套筒扳手



- Up to 14% Faster Fastening than Coded Model 6922NB

Standard Equipment: Screwdriver, Shoulder Belt, M20 Sleeve, M22 Sleeve

- ZK: With Carrying Case, Without Charger & Battery



Capacity Kapasiti 能力	High Strength Torque Shear Bolt (HTB): M16 (optional), M20, M22 (5/8", 3/4", 7/8") Super High Strength Torque Shear Bolt (SHTB): M16, M20 (5/8", 3/4")
No Load Speed (RPM) Kelajuan Tanpa Beban 回转数	14
Max Fastening Torque Tenaga Pemutaran Pengancing Maksimum 最大紧固扭力	804N-m (593ft.lbs.)
Dimensions (L x W x H) Dimensi 体积	296x130x377mm (11-5/8"x5-1/8"x14-7/8")
Net Weight Berat Bersih 净重	6.5 - 7.1kg (14.3 - 15.7lbs.)
Work Amount (approx.) Jumlah Kerja 工作量	300 pcs with BL1850B x2 M22 (7/8") Torque Shear Bolts

* All list price shown are for reference only (exclude SST).

* Semua harga yang ditunjukkan adalah untuk rujukan sahaja (tidak termasuk SST). 所有显示的建议零售价仅供参考 (不包括SST)。

Cordless
Target: No Cord

LED Flashlight
Lampu Suhu LED
LED 闪光灯

Vacuum Cleaner
Pembersih Vakuum
吸尘器

Drilling / Fastening
Gerudi / Pengancing
钻孔 / 紧固

Impact Drilling / Demolition
Gerudi / Penusuk
冲击钻孔 / 拆毁施工

Cutting
Pemotong
切割

Grinding / Sanding
Pengira / Pechin
研磨 / 砂磨

Sawing
Gergaji
锯切

Planing / Routing
Pergalan / Tunggam
刨削 / 埋线

Others
Lain-lain
其他

Outdoor Power Equipment
Alatan Kerja Luar
园机 / 户外





Li-ion Ah 6.0 5.0 4.0 3.0 2.0 1.5

DGA901Z | DGA900Z 230mm (9")

Cordless Angle Grinder
Pengisar Sudut Tanpa Kord
充电式角向磨光机



- Two 18V LXT Li-Ion batteries deliver the power and performance for corded demands without leaving the 18V LXT platform

Standard Equipment: Wheel Cover, Side Grip, Lock Nut Wrench

- Z: Without Charger & Battery

ONLY FOR DGA901



Wheel Diameter Diameter Mata Canai 砂轮片直径	230mm (9")
Hole Diameter Diameter Lubang 孔直径	22.23mm (7/8")
Max Wheel Thickness Ketebalan Roda 砂轮片厚度	6.5mm (1/4")
No Load Speed (RPM) Kelajuan Tanpa Beban 回转数	6,000
Max Output Keluaran Maksima 最大输出	1,500W
Dimensions (L x W x H) Dimensi 体积	499x250x158mm (19-5/8"x9-7/8"x6-1/4")
Net Weight Berat Bersih 净重	5.2 - 8.0kg (11.4 - 17.7lbs.)
Work Amount (approx.) Jumlah Kerja 工作量	17 cuts with BL1850B x2 Equiangular Angle Steel 50 x 50mm

DGA701Z | DGA700Z 180mm (7")

Cordless Angle Grinder
Pengisar Sudut Tanpa Kord
充电式角向磨光机



- BL motor eliminates carbon brushes, enabling the BL motor to run cooler and more efficiently for longer life

Standard Equipment: Wheel Cover, Side Grip, Lock Nut Wrench

- Z: Without Charger & Battery

ONLY FOR DGA701



Wheel Diameter Diameter Mata Canai 砂轮片直径	180mm (7")
Hole Diameter Diameter Lubang 孔直径	22.23mm (7/8")
Max Wheel Thickness Ketebalan Roda 砂轮片厚度	7.2 mm (1/4")
No Load Speed (RPM) Kelajuan Tanpa Beban 回转数	7,800
Max Output Keluaran Maksima 最大输出	1,500W
Dimensions (L x W x H) Dimensi 体积	499x200x158mm (19-5/8"x7-7/8"x6-1/4")
Net Weight Berat Bersih 净重	5.0 - 6.0kg (11.0 - 13.3lbs.)
Work Amount (approx.) Jumlah Kerja 工作量	17 cuts with BL1850B x2 Equiangular Angle Steel 50 x 50mm

DJR360RF4 | DJR360Z

Cordless Recipro Saw
Gergaji Resipro Tanpa Kord
充电式往复锯



- Electric 2 speed provides ideal RPM of high speed for wooden cutting and low speed for metal cutting

Standard Equipment: Recipro Saw Blades 2pcs (B-05175 & B-05169)

- RF4: 1x Rapid Charger, 4x 3.0Ah Battery
- Z: Without Charger, Battery & Carrying Case



Length of Stroke Panjang Strok 冲程长度	32mm (1-1/4")
Strokes Per Minute (SPM) Kelajuan Strok 冲程速度	High: 0 - 3,000 Low: 0 - 2,300
Capacity Kapasiti 能力	Pipe: 130mm (5-1/8") Wood: 255mm (10")
Dimensions (L x W x H) Dimensi 体积	449x116x243mm (17-3/4"x4-9/16"x9-9/16")
Net Weight Berat Bersih 净重	4.0 - 4.7kg (8.9 - 10.3lbs)
Work Amount (approx.) Jumlah Kerja 工作量	110 pcs with BL1850B x2 Steel Pipe (φ34 x 3mm)



DLW140 Cordless Portable Cut-off

CUTTING CAPACITY A workpiece thinner than 1.6mm is recommended for cutting with this tool

Form of Materials				
Miter Angle 0°	D: ø127mm (5")	H x W: 115 x 130 (4-1/2"x5-1/8") 102 x 194mm (4"x 7-5/8") 70 x 233mm (2-3/4"x 9-1/8")	H x W: 119 x 119mm (4-11/16"x 4-11/16")	S x S: 137 x 137mm (5-3/8"x 5-3/8")
Miter Angle 45°	D: ø127mm (5")	H x W: 115 x 103mm (4-1/2"x 4-1/16")	H x W: 106 x 106mm (4-3/16"x 4-3/16")	S x S: 100 x 100mm (4"x 4")

D: Diameter | W: Width | H: Height | S: Side

DLW140Z 355mm (14")

Cordless Portable Cut-off
Mesin Pemotong Tanpa Kord
充电式无刷轻钢架砂轮切断机



- World's First Cordless Portable Cut-off

Standard Equipment: Cut-Off Wheel (B-64696)

- Z: Without Charger & Battery



VIDEO CLIP
Models and specs may vary by country



Wheel Diameter Diameter Mata Canai 砂轮片直径	355mm (14")
Hole Diameter Diameter Lubang 孔直径	25.4mm (1")
Max Wheel Thickness Ketebalan Roda 砂轮片厚度	3mm (1/8")
No Load Speed (RPM) Kelajuan Tanpa Beban 回转数	3,800
Capacity at 90° Kapasiti Pemotongan 切割能力	Round: 127mm (5") Rectangular: 115x130mm (4-1/2"x5-1/8") Rectangular: 102x194mm (4"x7-5/8") Rectangular: 70x233mm (2-3/4"x9-1/8")
Capacity at 45° Kapasiti Pemotongan 切割能力	Round: 127mm (5") Rectangular: 115x103mm (4-1/2"x4-1/16")
Dimensions (L x W x H) Dimensi 体积	537x280x640mm (21-1/8"x11"x25-1/4")
Net Weight Berat Bersih 净重	17.2 - 17.8kg (37.9 - 39.3lbs.)
Work Amount (approx.) Jumlah Kerja 工作量	130 cuts with BL1850B x2 Metal Stud (H:75mm, W: 45mm, T: 0.8mm)

* All list price shown are for reference only (exclude SST).

* Semua harga yang ditunjukkan adalah untuk rujukan sahaja (tidak termasuk SST). 所有显示的建议零售价仅供参考 (不包括SST)。

Cordless Target Kord 无绳式
LED Flashlight Lampu Suluh LED LED 照明灯
Vacuum Cleaner Pembersih Vakuum 吸尘器
Drilling / Fastening Druai / Penempok 钻孔 / 紧固
Impact Drilling / Demolition Druai / Penempok 冲击钻孔 / 拆除加工
Cutting Pemotong 切割
Grinding / Sanding Pengisar / Pencil 磨削 / 研磨
Sawing Mengisar 锯切
Planing / Routing Pengaram / Tangkapan 刨削 / 锯架
Others Lain-lain 其他
Outdoor Power Equipment Alatan Kerja Luar 户外动力工具





Li-ion Ah 6.0 5.0 4.0 3.0 2.0 1.5

DLS211Z 305mm (12")

Cordless Slide Compound Miter Saw

Gergaji Kompaun Miter Tanpa Kord
充电式斜断锯



- Auto-start Wireless System (AWS) connects to vacuum cleaner with Bluetooth

Standard Equipment: TCT Saw Blade (B-67452), Dust Bag (1228520), Triangular Rule, Vertical Vise, Hex Wrench

- Z: Without Charger & Battery



Blade Diameter Diameter Bilah 锯片直径	305mm (12")
Miter Angle Sudut Miter 斜接角	60°L / 60°R
Bevel Angle Sudut Bevel 斜角	48°L / 48°R
Max Cutting Capacity Kapastiti Pemotongan Maksimum 最大切割能力	90° Miter: 107 x 363mm (4-1/4" x 14-1/4") 90° Miter: 92 x 382mm (3-5/8" x 15") 45° Miter, L/R: 107 x 255mm (4-1/4" x 10") 45° Miter, L/R: 92 x 268mm (3-5/8" x 10-1/2")
No Load Speed (RPM) Kelajuan Tanpa Beban 回转数	4,400
Dimensions (L x W x H) Dimensi 体积	898x690x725mm (35-1/4"x27-1/4"x28-1/2")
Net Weight Berat Bersih 净重	30.7 - 31.3kg (67.6 - 69.1lbs.)
Work Amount (approx.) Jumlah Kerja 工作量	90 cuts with BL1860B x2 Melapi thick 60mm x width 300mm at 90° slide cutting

DLS111Z 260mm (10-1/4")

Cordless Slide Compound Miter Saw

Gergaji Kompaun Miter Tanpa Kord
充电式斜断锯



- Auto-start Wireless System (AWS) connects to vacuum cleaner with Bluetooth

Standard Equipment: TCT Saw Blade (B-64668), Dust Bag (1228520), Triangular Rule, Vertical Vise, Hex Wrench

- Z: Without Charger & Battery



Blade Diameter Diameter Bilah 锯片直径	260mm (10-1/4")
Miter Angle Sudut Miter 斜接角	60°L / 60°R
Bevel Angle Sudut Bevel 斜角	48°L / 48°R
Max Cutting Capacity Kapastiti Pemotongan Maksimum 最大切割能力	90° Miter: 91 x 279mm (3-5/8" x 11") 90° Miter: 68 x 310mm (2-11/16" x 12-1/4") 45° Miter, L/R: 91 x 197mm (3-5/8" x 7-3/4") 45° Miter, L/R: 68 x 218mm (2-11/16" x 8-5/8")
No Load Speed (RPM) Kelajuan Tanpa Beban 回转数	4,400
Dimensions (L x W x H) Dimensi 体积	805x644x660mm (31-3/4"x25-3/8"x26")
Net Weight Berat Bersih 净重	26.6 - 27.3kg (58.6 - 60.2 lbs.)
Work Amount (approx.) Jumlah Kerja 工作量	150 cuts with BL1860B x2 Melapi thick 60mm x width 300mm at 90° slide cutting

DLS714PM2 | **DLS714Z** 190mm (7-1/2")

Cordless Slide Compound Miter Saw

Gergaji Kompaun Miter Tanpa Kord
充电式斜断锯



- Large cutting capacity; Crosscuts up to 52 x 300 mm (2-1/16" x 11-3/4") at 90°

Standard Equipment: TCT Saw Blade (B-03850), Dust Bag (1228520), Holder Set, Vertical Vise, Hex Wrench, Triangular Rule

- PM2: 1x Two Port Multi Fast Charger, 2x 4.0Ah Battery
- Z: Without Charger & Battery



Blade Diameter Diameter Bilah 锯片直径	190mm (7-1/2")
Miter Angle Sudut Miter 斜接角	47°L / 57°R
Bevel Angle Sudut Bevel 斜角	45°L / 5°R
Max Cutting Capacity Kapastiti Pemotongan Maksimum 最大切割能力	90°: 52 x 300mm (2-1/16" x 11-3/4") at 45° left: 40 x 300mm (1-9/16" x 11-3/4") at 5° right: 40 x 300mm (1-9/16" x 11-3/4")
No Load Speed (RPM) Kelajuan Tanpa Beban 回转数	5,700
Dimensions (L x W x H) Dimensi 体积	655x430x445mm (25-3/4"x17"x17-1/2")
Net Weight Berat Bersih 净重	12.6kg (27.8lbs)
Work Amount (approx.) Jumlah Kerja 工作量	350 pcs with BL1850B x2 SPF Material 2x4"

DHS900PT2 | **DHS900Z** 235mm (9-1/4")

Cordless Circular Saw

Gergaji Piring Tanpa Kord
充电式圆锯



- Auto-start Wireless System (AWS) connects to vacuum cleaner with Bluetooth
- Compatible with guide rail without adapter, providing precision cutting

Standard Equipment: TCT Saw Blade (E-01959), Sub Base, Hex Wrench

- PT2: 1x Two Port Multi Fast Charger, 2x 5.0Ah Battery
- Z: Without Charger, Battery & Carrying Case



Blade Diameter Diameter Bilah 锯片直径	235mm (9-1/4")
Hole Diameter Diameter Lubang 孔直径	15.88mm (5/8") 25mm (1") 25.4mm (1") 30mm (1-3/16")
Max Cutting Capacity Kapastiti Pemotongan Maksimum 最大切割能力	90°: 85mm (3-3/8") 45°: 61mm (2-3/8") 60°: 44mm (1-3/4")
No Load Speed (RPM) Kelajuan Tanpa Beban 回转数	4,500
Dimensions (L x W x H) Dimensi 体积	413x196x316mm (16-1/4"x7-3/4"x12-1/2")
Net Weight Berat Bersih 净重	5.3 - 6.0kg (11.7 - 13.2lbs.)
Work Amount (approx.) Jumlah Kerja 工作量	110 cuts with BL1850B x2 Oak wood (thickness 80mm x width 300mm) at 90° cutting

DHS783Z | **DHS782Z** 190mm (7-1/2") / 185mm (7-1/4")

Cordless Circular Saw

Gergaji Piring Tanpa Kord
充电式圆锯



- Auto-start Wireless System (AWS) connects to vacuum cleaner with Bluetooth
- Compatible with Guide Rail without Adapter

Standard Equipment: TCT Saw Blade (B-62022), Hex Wrench, Guide Rule, Dust Nozzle

- Z: Without Charger & Battery



VIDEO CLIP
Model and specs may vary by country

ONLY FOR DHS783

Blade Diameter Diameter Bilah 锯片直径	190mm (7 - 1/2") 185mm (7 - 1/4")
Hole Diameter Diameter Lubang 孔直径	15.88mm (5/8") 20mm (13/16") 30mm (1-3/16")
Max Cutting Capacity Kapastiti Pemotongan Maksimum 最大切割能力	90°: 62.5/ 60mm (2-7/16"/ 2-3/8") 45°: 44.5/ 43mm (1-3/4"/ 1-11/16") 48°: 42/ 41mm (1-5/8"/ 1-5/8")
No Load Speed (RPM) Kelajuan Tanpa Beban 回转数	6,000
Max Output Keluaran Maksima 最大输出	1,800W
Dimensions (L x W x H) Dimensi 体积	348x210x290mm (13-3/4"x8-1/4"x11-3/8")
Net Weight Berat Bersih 净重	4.5 - 5.1kg (9.9 - 11.3lbs.)
Work Amount (approx.) Jumlah Kerja 工作量	190 cuts with BL1850B x2 Melapi thickness 50mm x width 300mm at 90° cutting

* All list price shown are for reference only (exclude SST).

* Semua harga yang ditunjukkan adalah untuk rujukan sahaja (tidak termasuk SST). 所有显示的建议零售价仅供参考 (不包括SST)。

Cordless
Target Model Series

LED Flashlight
Lampu Sahan LED
LED手电筒

Vacuum Cleaner
Pembersih Vakuum
吸尘器

Drilling / Fastening
Ganuli / Pengikat
钻孔 / 紧固

Impact Drilling / Demolition
Ganuli / Penusuk
冲击钻孔 / 拆毁

Cutting
Pemotong
切割

Grinding / Sanding
Pengkil / Poles
研磨 / 砂磨

Sawing
Gergaji
锯切

Planing / Routing
Penghalus / Tumpang
刨平 / 压花

Others
Lain-lain
其他

Outdoor Power Equipment
Alatan Kuat Luar
园机 / 户外





Li-ion Ah 6.0 5.0 4.0 3.0 2.0 1.5

DHS710RM2J | DHS710RF2J 190mm (7-1/2")

442 mm

Cordless Circular Saw
Gergaji Piring Tanpa Kord
充电式圆锯



- Lightweight for operator comfort

Standard Equipment: TCT Saw Blade (D-09123), Rip Fence (Guide Rule), Hex Wrench

- RM2J: 1x Rapid Charger, 2x 4.0Ah Battery, 1x Makpac Connector Box
- RF2J: 1x Rapid Charger, 2x 3.0Ah Battery, 1x Makpac Connector Box



VIDEO CLIP
Models and specs may vary by country

Blade Diameter Diameter Bilah 锯片直径	190/ 185mm (7-1/2"/ 7-1/4")
Max Cutting Capacity Kapasiti Pemotongan Maksimum 最大切割能力	90°: 68.5/ 66mm (2-11/16"/ 2-5/8") 45°: 49/ 47.5mm (1-15/16"/ 1-7/8") 50°: 44/ 42.5mm (1-3/4"/ 1-11/16") 4,800
No Load Speed (RPM) Kelajuan Tanpa Beban 回转速数	
Dimensions (L x W x H) Dimensi 体积	356x217x298mm (14"x8-1/2"x11-3/4")
Net Weight Berat Bersih 净重	3.9 - 4.6kg (8.6 - 10.1lbs)
Work Amount (approx.) Jumlah Kerja 工作量	205 pcs with BL1850B x2 SPF 2 x 10 (thickness 38mm, width 235mm), 90° cut

DRS780Z 185mm (7-1/4")

Cordless Rear Handle Saw
Gergaji Piring Tanpa Kord
充电式后把手圆锯



Opposite Handling
Cut left side of material



- Cuts 3X Material in a Single Pass;
Blade Left Design

Standard Equipment: TCT Saw Blade (B-62022), Offset Wrench

- Z: Without Charger & Battery



Blade Diameter Diameter Bilah 锯片直径	185mm (7-1/4")
Max Cutting Capacity Kapasiti Pemotongan Maksimum 最大切割能力	90°: 65mm (2-9/16") 45°: 45mm (1-3/4") 53°: 38mm (1-1/2")
No Load Speed (RPM) Kelajuan Tanpa Beban 回转速数	5,100
Dimensions (L x W x H) Dimensi 体积	446x196x270mm (17-1/2"x7-3/4"x10-5/8")
Net Weight Berat Bersih 净重	5.0 - 5.6kg (11.1 - 12.4lbs.)
Work Amount (approx.)	290 cuts with BL1850B x2 SPF 2 x 10 (thickness 38mm, width 235mm), 90° cut

DSP601Z | DSP600Z 165mm (6-1/2")

Cordless Plunge Cut Saw
Gergaji Piring Tanpa Kord
充电式圆锯



- Auto-start Wireless System (AWS) connects to vacuum cleaner with Bluetooth

Standard Equipment: TCT Saw Blade (B-57364), Hex Wrench

- Z: Without Charger & Battery



ONLY FOR DSP601

Blade Diameter Diameter Bilah 锯片直径	165mm (6-1/2")
Bevel Capacity Kapasiti Bevel 斜角容量	-1° - 48°
Max Cutting Capacity Kapasiti Pemotongan Maksimum 最大切割能力	90°: 56mm (2-3/16") 45°: 40 mm (1-9/16") 48°: 38 mm (1-1/2")
No Load Speed (RPM) Kelajuan Tanpa Beban 回转速数	2,500 - 6,300
Dimensions (L x W x H) Dimensi 体积	346x241x272mm (13-5/8"x9-1/2"x10-3/4")
Net Weight Berat Bersih 净重	4.4 - 5.1kg (9.8 - 11.2lbs.)
Work Amount (approx.) Jumlah Kerja 工作量	48 cuts with BL1850B x2 Melamine Board 32mm (Thick) x 1000mm (Length)



DCE090Z 230mm (9")

Cordless Power Cutter
Mesin Pemotong Tanpa Kord
充电式切断机



- Battery cover protects battery from water in wet cutting

Standard Equipment: Hex Wrench, Wrench, Coupling Sleeve

- Z: Without Charger & Battery



Wheel Diameter Diameter Bilah 锯片直径	230mm (9")
Wheel Hole Diameter Diameter Lubang 孔直径	22.23mm (7/8")
Max Wheel Thickness Ketebalan Roda Maksimum 最大轮片厚度	3.0mm (1/8")
Max Cutting Capacity Kapasiti Pemotongan Maksimum 最大切割能力	88mm (3-1/2")
No Load Speed (RPM) Kelajuan Tanpa Beban 回转速数	6,600
Dimensions (L x W x H) Dimensi 体积	554x241x283mm (21-3/4x9-1/2x11-1/8")
Net Weight Berat Bersih 净重	5.6 - 6.3kg (12.3 - 13.9lbs.)
Work Amount (approx.) Jumlah Kerja 工作量	Concrete Cutting 30mm depth 7.8m length with Diamond Wheel with BL1860B x2

* All list price shown are for reference only (exclude SST).

* Semua harga yang ditunjukkan adalah untuk rujukan sahaja (tidak termasuk SST). 所有显示的建议零售价仅供参考 (不包括SST)。

Cordless Target Kord 无绳式
LED Flashlight Lampu Suluh LED LED 照明灯
Vacuum Cleaner Pembersih Vakuum 吸尘器
Drilling / Fastening Bor / Pasang 钻孔 / 紧固
Impact Drilling / Demolition Bor / Perseki 冲击钻孔 / 拆除加工
Cutting Pemotong 切割
Grinding / Sanding Pengisar / Pasih 研磨 / 打磨
Sawing Mengkilat 锯切
Planing / Routing Pengisar / Tangkai 刨削 / 磨边
Others Lain-lain 其他
Outdoor Power Equipment Alatan Kerja Luar 户外动力工具





Li-ion Ah 6.0 5.0 4.0 3.0 2.0 1.5

DUR369LZ

Cordless Grass Trimmer
Pemotong Rumput Tanpa Kord
充电式割草机

- 1.0kW max output power similar to 30mL class engine grass trimmers

Standard Equipment: Safety Goggles (195246-2), Metal Blade, Nylon Cutting Head, Plastic Blade, Blade cover (for metal blade), Accessory Bag, Hex Wrench, Box Wrench, Band Assembly

- LZ: Without Charger & Battery



Max Output Keluaran Maksima 最大输出	1,000W
Cutting Width Lebar Keratan 切割宽度	Metal Blade: 255mm (10") Plastic Blade: 305mm (12") Nylon Cutting Head: 430mm (17")
No Load Speed (RPM) Kelajuan Tanpa Beban 回转数	Metal Blade (3/2/1): 0 - 7,000 / 0 - 5,500 / 0 - 4,600 Nylon Cutting Head (3/2/1): 0 - 5,500 / 0 - 5,000 / 0 - 4,600
	Plastic Blade (305mm) (3/2/1): 0 - 7,000 / 0 - 5,500 / 0 - 4,600 Plastic Blade (255mm) (3/2/1): 0 - 5,500 / 0 - 5,000 / 0 - 4,600
Spindle Size Saiz Spindel 主轴尺寸	M10 x 1.25LH
Dimensions (L x W x H) Dimensi 体积	1,846x400x269mm (72-1/2"x15-3/4"x10-5/8")
Net Weight Berat Bersih 净重	5.7 - 6.3kg (12.6 - 13.9lbs.)
Continuous Usage Time (approx.) Masa Penggunaan Berterusan 连续使用时间	Low: 38 min with BL1860B x2 Metal blade with load

DUR368LPT2 | DUR368LZ

Cordless Grass Trimmer
Pemotong Rumput Tanpa Kord
充电式割草机

- Lightweight for reduced operator fatigue

Standard Equipment: Safety Goggles (195246-2), Plastic Blade (198384-9), Accessory Bag, Hex Wrench, Band Assembly

- LPT2: 1x Two Port Multi Fast Charger, 2x 5.0Ah Battery
- LZ: Without Charger & Battery

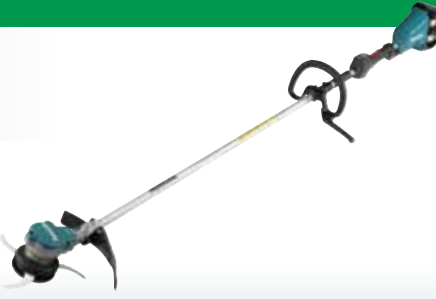

Max Output Keluaran Maksima 最大输出	550W
Cutting Width Lebar Keratan 切割宽度	Metal Blade: 230mm (9") Trimmer Head: 350mm (13-3/4") Plastic Blade: 255mm (10")
No Load Speed (RPM) Kelajuan Tanpa Beban 回转数	High: 6,500 Med: 5,300 Low: 3,500
Spindle Size Saiz Spindel 主轴尺寸	M10 x 1.25LH
Dimensions (L x W x H) Dimensi 体积	1,758x362x231mm (69-1/4"x14-1/4"x9-1/8")
Net Weight Berat Bersih 净重	3.9 - 4.5kg (8.6 - 10.0lbs.)
Continuous Usage Time (approx.) Masa Penggunaan Berterusan 连续使用时间	Low: 106 min with BL1860B x2 Plastic blade with load

DUR368APT2 | DUR368AZ

Cordless Grass Trimmer
Pemotong Rumput Tanpa Kord
充电式割草机

- Lightweight for reduced operator fatigue

Standard Equipment: Safety Goggles (195246-2), Plastic Blade, Accessory Bag, Hex Wrench, Band Assembly

- APT2: 1x Two Port Multi Fast Charger, 2x 5.0Ah Battery
- AZ: Without Charger & Battery



Max Output Keluaran Maksima 最大输出	550W
Cutting Width Lebar Keratan 切割宽度	Metal Blade: 255mm (10") Trimmer Head: 350mm (13-3/4") Plastic Blade: 255mm (10")
No Load Speed (RPM) Kelajuan Tanpa Beban 回转数	High: 6,500 Med: 5,300 Low: 3,500
Spindle Size Saiz Spindel 主轴尺寸	M10 x 1.25LH
Dimensions (L x W x H) Dimensi 体积	1,758x615x442mm (69-1/4"x24-1/4"x17-3/8")
Net Weight Berat Bersih 净重	4.1 - 4.7kg (9.0 - 10.5lbs.)
Continuous Usage Time (approx.) Masa Penggunaan Berterusan 连续使用时间	Low: 106 min with BL1860B x2 Plastic blade with load

DUR364LPM4 | DUR364LRM2 | DUR364LZ

Cordless Grass Trimmer
Pemotong Rumput Tanpa Kord
充电式割草机

- 2-Speed options allows the operator to match speed to application

Standard Equipment: Safety Goggles (195246-2), Nylon Cutting Head, Accessory Bag, Hex Wrench

- LPM4: 1x Two Port Multi Fast Charger, 4x 4.0Ah Battery
- LRM2: 1x Rapid Charger, 2x 4.0Ah Battery
- LZ: Without Charger & Battery



Max Output Keluaran Maksima 最大输出	550W
Cutting Width Lebar Keratan 切割宽度	Trimmer Head: 350mm (13-3/4") Plastic Blade: 255mm (10")
No Load Speed (RPM) Kelajuan Tanpa Beban 回转数	High: 6,500 Low: 5,000
Spindle Size Saiz Spindel 主轴尺寸	M8 x 1.25RH
Dimensions (L x W x H) Dimensi 体积	1,754x310x229mm (69"x12-1/4"x9")
Net Weight Keberatan 净重	3.6 - 4.4kg (8.0 - 9.7lbs)
Continuous Usage Time (approx.) Masa Penggunaan Berterusan 连续使用时间	Low: 60 min High: 34 min with BL1850B x2 Nylon cutting head with load

DUP362ZN

Battery Powered Pruning Shears
Gunting Pemangkas Bateri
充电式电剪

- Extra sharp, Made-in-Japan forged blade

Standard Equipment: Oil Supply, Wrench Set, Diamond File, Cord Holder, Holster, Harness, Arm Band, Tool Bag, Shear Blade

- ZN: Without Charger & Battery



Max Output Keluaran Maksima 最大输出	200W
Capacity Kapasiti 能力	Max Cutting : 33mm (1-5/16") Max Blade Opening: 54mm
Cutting Torque Tork Pemotongan 切割扭矩	250N
Dimensions (L x W x H) Dimensi 体积	305x43x106mm (12"x1-11/16"x4-3/16")
Net Weight Keberatan 净重	0.77 - 0.82kg (1.7 - 1.8lbs.)
Work Amount (approx.) Jumlah Kerja 工作量	71,000cuts with BL1850B x2 (ø15mm Grape Wine Branch)



VIDEO CLIP
Models and specs may vary by country

* All list price shown are for reference only (exclude SST).

* Semua harga yang ditunjukkan adalah untuk rujukan sahaja (tidak termasuk SST). 所有显示的建议零售价仅供参考 (不包括SST)。

Cordless
Target Applications

LED Flashlight
Lampu Suli LED
LED手电筒

Vacuum Cleaner
Pembersih Vakum
吸尘器

Drilling / Fastening
Gantut / Pengikat
钻孔 / 紧固

Impact Drilling / Demolition
Gantut / Pemusnah
冲击钻孔 / 摧毁施工

Cutting / Sanding
Pengira / Poles
切割 / 砂磨

Grinding / Routing
Pengira / Trogam
研磨 / 雕刻

Sawing / Gouging
Gigit
锯切

Planing / Routing
Pengira / Trogam
刨削 / 雕刻

Others
Lain-lain
其他

Outdoor Power Equipment
Alatan Kuat Luar
园具 / 户外





Li-ion Ah 6.0 5.0 4.0 3.0 2.0 1.5

DUP361Z

Battery Powered Pruning Shears
Gunting Pemangkas Bateri
充电式电剪



- Extra sharp, Made-in-Japan forged blade

Standard Equipment: Oil Supply, Wrench Set, Diamond File, Cord Holder, Holster, Harness, Arm Band, Tool Bag, Shear Blade

• Z: Without Charger & Battery



Max Output Keluaran Maksima 最大输出	200W
Capacity Kapasiti 能力	Max Cutting : 33mm Max Blade Opening: 54mm
Cutting Torque Tork Pemotongan 切割扭矩	185N
Dimensions (L x W x H) Dimensi 体积	305x43x106mm (12"x1-11/16"x4-3/16")
Net Weight Keberatan 净重	0.8kg (1.8lbs)
Work Amount (approx.) Jumlah Kerja 工作量	71,000cuts with BL1850B x2 (ø15mm Grape Wine Branch)



DUP361

VIDEO CLIP
Models and specs may vary by country

DUX60
Cordless Multi Function Power Head



Max Output
0.6kW

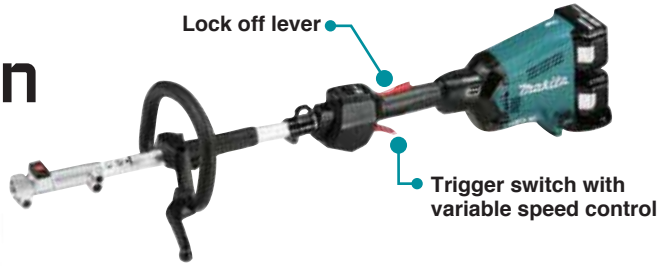

<p>Brushcutter</p> <ul style="list-style-type: none"> EM400MP Part No. 195657-1 EM403MP Part No. 198760-7 *UX01G / DUX60 only <p>Grass Trimmer</p> <ul style="list-style-type: none"> EM408MP Part No. 191N34-9 EM409MP Part No. 191N46-2 	<p>Power brush</p> <ul style="list-style-type: none"> BR400MP Part No. 199323-2 	<p>Power sweep</p> <ul style="list-style-type: none"> SW400MP Part No. 199344-4 	<p>Ground trimmer</p> <ul style="list-style-type: none"> EN420MP (Angle adjustable) Part No. 198061-3 	<p>Hedge trimmer</p> <ul style="list-style-type: none"> EN410MP (Straight) Part No. 197742-6 	<p>Pole hedge trimmer</p> <ul style="list-style-type: none"> EN401MP (Angle adjustable) Part No. 196341-1 	<p>Shaft extension attachment</p> <ul style="list-style-type: none"> LE400MP Part No. 191E23-0 Length: 1,080mm (42-1/2") for Pole saw, Pole hedge trimmer and Coffee harvester 	<p>Coffee harvester</p> <ul style="list-style-type: none"> EJ400MP Part No. 197163-2 	<p>Pole saw</p> <ul style="list-style-type: none"> EY401MP Part No. 199925-4 EY403MP Part No. 191T41-8 	<p>Edger</p> <ul style="list-style-type: none"> EE400MP Part No. 196752-0 	<p>Cultivator</p> <ul style="list-style-type: none"> KR400MP Part No. 195716-1 KR401MP Part No. 199185-8
--	---	---	---	--	---	--	--	---	---	---

DUX60ZM3 DUX60Z

Cordless Multi Function Power Head

Powerhead Pelbagai Fungsi
Tanpa Kord
充电式多功能动力机



- Multi-tool system consisting of power head and versatile optional attachments is ideal for a wide range of applications

Standard Equipment: Band Assembly, Hex Wrench, Accessory Bag
DUX60ZM3: Brushcutter Attachment EM403, Nylon Cutting Head, 3 Tooth Blade, 3 Tooth Blade Cover, Tool bag, Box Wrench 17, Metal Blade Fixing Tool (Clamp Washer, Nut, Cup)

• ZM3: Without Charger & Battery • Z: Without Charger & Battery



Max Output Keluaran Maksima 最大输出	600W
No Load Speed (RPM) Kelajuan Tanpa Beban 回转速	High: 0 - 9,700 Med: 0 - 8,200 Low: 0 - 5,700
Dimensions (L x W x H) Dimensi 体积	1,011x320x216mm (39-3/4"x12-5/8"x8-1/2")
Net Weight Berat Bersih 净重	4.1 - 8.7kg (8.9 - 19.2lbs)
Continuous Usage Time (approx.) Masa Penggunaan Berterusan 连续使用时间	Low: 97 min Med: 35 min High: 21 min with BL1850B x2 Grass Trimmer



DUX60

VIDEO CLIP
Models and specs may vary by country

DLM533Z 530mm (21")

Cordless Lawn Mower
Mesin Pemotong Rumput
Tanpa Kord
充电式手推割草机



- Aluminum die-cast deck does not rust even if scratched or damaged

Standard Equipment: Blade, Mulching Plug, Socket Wrench, Rod

• Z: Without Charger & Battery



Max Output Keluaran Maksima 最大输出	1,600W
Cutting Width Lebar Keratan 切割宽度	534mm (21")
Cutting Height Ketinggian Pemotongan 切割高度	20 - 100mm (13/16 - 3-15/16")
Grass Box Capacity Kapasiti Kotak Rumput 草箱容量	70L
No Load Speed (RPM) Kelajuan Tanpa Beban 回转速	Standard Mode: 2,300 / 2,800 Low Noise Mode: 2,300
Propelling Speed Kelajuan Mendorong 推进速度	2.5 - 5.0 km/h
Dimensions (L x W x H) Dimensi 体积	1,655-1,740x590x990-1,100mm (65-68-1/2x23-1/4x39-43-1/4")
Net Weight Berat Bersih 净重	42.8 - 46.7kg (94.4 - 103lbs.)
Continuous Usage Time (approx.) Masa Penggunaan Berterusan 连续使用时间	40 min (Self-Propelled) with BL1860B x2

* All list price shown are for reference only (exclude SST).

* Semua harga yang ditunjukkan adalah untuk rujukan sahaja (tidak termasuk SST). 所有显示的建议零售价仅供参考 (不包括SST)。

Cordless Target Kord Tanpa Kord
LED Flashlight Lampu Suluh LED LED 照明灯
Vacuum Cleaner Pemilauhi VAKUUM 吸尘器
Drilling / Fastening Daurul / Penempok 钻头 / 螺絲
Impact Drilling / Demolition Daurul / Penempok 钻头 / 螺絲
Cutting Pemotong 切割
Grinding / Sanding Pengisar / Pasukan 磨粉 / 砂磨
Sawing Gergaji 电锯
Planing / Routing Pengisar / Tangkai 磨粉 / 螺絲
Others Lain-lain 其他
Outdoor Power Equipment Alatan Kerja Luar 园具-户外





Li-ion Ah 6.0 5.0 4.0 3.0 2.0 1.5

DLM532Z 530mm (21")

Cordless Lawn Mower
Mesin Pemotong Rumput
Tanpa Kord
充电式手推割草机



- IPX4 water resistant for use in bad weather

Standard Equipment: Blade, Mulching Plug, Side Discharge Mouth, Socket Wrench, Rod

• Z: Without Charger & Battery



Max Output Keluaran Maksima 最大输出	1,600W
Cutting Width Lebar Keratan 切割宽度	534mm (21")
Cutting Height Ketinggian Pemotongan 切割高度	20 - 100mm (13/16" - 3-15/16")
Grass box capacity Kapasiti Kotak Rumput 草箱容量	70L
No Load Speed (RPM) Kelajuan Tanpa Beban 回转数	2,300 - 2,800
Dimensions (L x W x H) Dimensi 体积	1,630-1,715x590x990-1,095mm (64"-67-1/2"x23-1/4"x39"-43")
Net Weight Berat Bersih 净重	39.0 - 42.8kg (86.0 - 94.4lbs.)
Continuous Usage Time (approx.) Masa Penggunaan Berterusan 连续使用时间	40 min (self-propelled) 54 min (push-drive) with BL1860B x2

DLM539Z 530mm (21")

Cordless Lawn Mower
Mesin Pemotong Rumput
Tanpa Kord
充电式手推割草机



- 4 in 1 (Cutting/ Collecting/ Mulching/ Rear discharge) & water-resistant cutting deck

Standard Equipment: Blade, Mulching Plug, Socket Wrench, Rod

• Z: Without Charger & Battery



Max Output Keluaran Maksima 最大输出	860W
Cutting Width Lebar Keratan 切割宽度	534mm (21")
Cutting Height Ketinggian Pemotongan 切割高度	20 - 100mm (13/16" - 3-15/16")
Grass Box Capacity Kapasiti Kotak Rumput 草箱容量	70L
No Load Speed (RPM) Kelajuan Tanpa Beban 回转数	3,000
Dimensions (L x W x H) Dimensi 体积	1,810-1,870x580x920-1,040mm (71-1/4"-73-1/2"x23x36-1/4"-41")
Net Weight Berat Bersih 净重	28.0 - 30.5kg (61.7 - 67.2lbs.)
Continuous Usage Time (approx.) Masa Penggunaan Berterusan 连续使用时间	22 min (Self-Propelled) 25 min (Push-Drive) with BL1860B x2

DLM480Z 480mm (18-7/8")

Cordless Lawn Mower
Mesin Pemotong Rumput
Tanpa Kord
充电式手推割草机



- 4 in 1 (Cutting/ Collecting/ Mulching/ Rear discharge) & water-resistant cutting deck

Standard Equipment: Blade, Mulching Plug, Wrench, Rod

• Z: Without Charger & Battery



Max Output Keluaran Maksima 最大输出	860W
Cutting Width Lebar Keratan 切割宽度	480mm (18-7/8")
Cutting Height Ketinggian Pemotongan 切割高度	20 - 100mm (13/16" - 3-15/16")
Grass Box Capacity Kapasiti Kotak Rumput 草箱容量	62L
No Load Speed (RPM) Kelajuan Tanpa Beban 回转数	3,100
Dimensions (L x W x H) Dimensi 体积	1,690-1,740x530x930-1,060mm (66-1/2"-68-1/2"x20-7/8x36-5/8-41-3/4")
Net Weight Berat Bersih 净重	24.5 - 26.8kg (54.0 - 59.1lbs.)
Continuous Usage Time (approx.) Masa Penggunaan Berterusan 连续使用时间	Mowing Area 800m ² (Push-Drive) or 28 min (Push-Drive) with BL1860B x2

DLM460Z 460mm (18")

Cordless Lawn Mower
Mesin Pemotong Rumput
Tanpa Kord
充电式手推割草机



- IPX4 water resistant for use in bad weather

Standard Equipment: Blade, Socket Wrench

• Z: Without Charger & Battery



Max Output Keluaran Maksima 最大输出	1,450W
Cutting Width Lebar Keratan 切割宽度	460mm (18")
Cutting Height Ketinggian Pemotongan 切割高度	20 - 75mm (13/16" - 2-15/16")
Grass Box Capacity Kapasiti Kotak Rumput 草箱容量	60L
No Load Speed (RPM) Kelajuan Tanpa Beban 回转数	2,500 - 3,300
Recommended Mowing Area Julat Memotong Yang Disyorkan 推荐的割草范围	With BL1850B x2: 680 - 1,360m ²
Dimensions (L x W x H) Dimensi 体积	1,319-1,518 x 532 x 879-1,138mm (52"-59-3/4" x 21" x 34-1/2"-44-3/4")
Net Weight Berat Bersih 净重	25.3 - 27.6kg (55.8 - 60.8lbs.)
Continuous Usage Time (approx.) Masa Penggunaan Berterusan 连续使用时间	18 min with BL1850B x2

DLM432PT2 | DLM432Z 430mm (17")

Cordless Lawn Mower
Mesin Pemotong Rumput
Tanpa Kord
充电式手推割草机

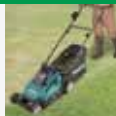

- Low noise level suitable for use in residential areas and public spaces

Standard Equipment: Blade, Mulching Plug, Socket Wrench

• PT2: 1x Two Port Multi Fast Charger, 2x 5.0Ah Battery

• Z: Without Charger & Battery



Max Output Keluaran Maksima 最大输出	950W
Cutting Width Lebar Keratan 切割宽度	430mm (17")
Cutting Height Ketinggian Pemotongan 切割高度	20 - 75mm (13/16" - 2-15/16")
Grass Box Capacity Kapasiti Kotak Rumput 草箱容量	50L
No Load Speed (RPM) Kelajuan Tanpa Beban 回转数	3,600
Dimensions (L x W x H) Dimensi 体积	1,435-1,490x460x1,005-1,045mm (56-1/2"-58-3/4"x18-1/8"x39-1/2"-41-1/4")
Net Weight Berat Bersih 净重	16.8 - 17.5kg (37.0 - 38.6lbs.)
Continuous Usage Time (approx.) Masa Penggunaan Berterusan 连续使用时间	30 min with BL1850B x2

* All list price shown are for reference only (exclude SST).

* Semua harga yang ditunjukkan adalah untuk rujukan sahaja (tidak termasuk SST). 所有显示的建议零售价仅供参考 (不包括SST)。

Cordless
Target Area 30x30cm

LED Flashlight
Lampu Suhu LED
LED照灯

Vacuum Cleaner
Pembersih Vakuum
吸尘器

Drilling / Fastening
Ganda / Pengikat
钻孔 / 紧固

Impact Drilling / Demolition
Ganda / Pemusnah
冲击钻孔 / 摧毁施工

Cutting
Pemotong
切割

Grinding / Sanding
Pengkilan / Poles
研磨 / 砂磨

Sawing
Ganda
锯切

Planing / Routing
Pengkilan / Tumpang
刨削 / 压花

Others
Lain-lain
其他

Outdoor Power Equipment
Alatan Kuat Luar
户外动力设备

Thakita
TENT



Li-ion Ah 6.0 5.0 4.0 3.0 2.0 1.5

DLM431PT2 | DLM431Z 430mm (17")

Cordless Lawn Mower

Mesin Pemotong Rumput Tanpa Kord
充电式手推割草机



- Large 50L capacity grass basket reduces the need for emptying

Standard Equipment: Blade, Socket Wrench

- PT2: 1x Two Port Multi Fast Charger, 2x 5.0Ah Battery
- Z: Without Charger & Battery



Max Output Keluaran Maksima 最大输出	730W
Cutting Width Lebar Keratan 切割宽度	430mm (17")
Cutting Height Ketinggian Pemotongan 切割高度	20 - 75mm (13/16" - 2-15/16")
Grass Box Capacity Kapasiti Kotak Rumput 草箱容量	50L
No Load Speed (RPM) Kelajuan Tanpa Beban 回转数	3,600
Dimensions (L x W x H) Dimensi 体积	1,450-1,490x460x950-1,020mm (57-58-3/4"x18-1/8"x37-1/2"-40-1/4")
Net Weight Keberatan 净重	17.8 - 18.4kg (39.2 - 40.6lbs)
Continuous Usage Time (approx.) Masa Penggunaan Berterusan 连续使用时间	30 min with BL1850B x2

DLM382PT2 | DLM382CM2 | DLM382Z 380mm (15")

Cordless Lawn Mower

Mesin Pemotong Rumput Tanpa Kord
充电式手推割草机



- Zero emissions and reduced maintenance; no need for gas or oil

Standard Equipment: Blade, Mulching Plug, Socket Wrench

- PT2: 1x Two Port Multi Fast Charger (DC18RD), 2x 5.0Ah Battery
- CM2: 1x Two Port Multi Charger (DC18SH), 2x 4.0Ah Battery
- Z: Without Charger & Battery



Max Output Keluaran Maksima 最大输出	900W
Cutting Width Lebar Keratan 切割宽度	380mm (15")
Cutting Height Ketinggian Pemotongan 切割高度	20 - 75mm (13/16" - 2-15/16")
Grass Box Capacity Kapasiti Kotak Rumput 草箱容量	40L
No Load Speed (RPM) Kelajuan Tanpa Beban 回转数	3,700
Dimensions (L x W x H) Dimensi 体积	1,380-1,410x450x985-1,005mm (54-1/4"-55-1/2"x17-3/4"x38-3/4"-39-1/2")
Net Weight Berat Bersih 净重	16.2 - 16.9 kg (35.7 - 37.3 lbs.)
Continuous Usage Time (approx.) Masa Penggunaan Berterusan 连续使用时间	36 min with BL1860B x2

DLM380Z 380mm (15")

Cordless Lawn Mower

Mesin Pemotong Rumput Tanpa Kord
充电式手推割草机



- Zero emissions and reduced maintenance

Standard Equipment: Blade, Wrench

- Z: Without Charger & Battery



Max Output Keluaran Maksima 最大输出	620W
Cutting Width Lebar Keratan 切割宽度	380mm (15")
Cutting Height Ketinggian Pemotongan 切割高度	25 - 75mm (1" - 2-15/16")
Grass Box Capacity Kapasiti Kotak Rumput 草箱容量	40L
No Load Speed (RPM) Kelajuan Tanpa Beban 回转数	3,700
Dimensions (L x W x H) Dimensi 体积	1,145x465x1,023-1,070mm (45"x18-1/4"x40-1/4"-42")
Net Weight Keberatan 净重	14.5kg (32.0lbs)
Continuous Usage Time (approx.) Masa Penggunaan Berterusan 连续使用时间	30 min with BL1850B x2

Model	Deck	Self-Propelled	BL MOTOR	Battery slots	Cutting	Collecting	Mulching	Rear discharge	Side discharge
DLM533	Aluminum	✓	✓	4	✓	✓	✓	✓	
DLM532	Steel	✓	✓	4	✓	✓	✓		✓
DLM539	Plastic	✓		2	✓	✓	✓	✓	
DLM480	Plastic			2	✓	✓	✓	✓	
DLM460	Steel		✓	2	✓	✓	✓		
DLM432	Plastic			2	✓	✓	✓*		
DLM431	Plastic			2	✓	✓			
DLM382	Plastic			2	✓	✓	✓*		
DLM380	Plastic			2	✓	✓			

* Optional accessory for Mulching (DLM432 / DLM382)

DUA301ZB

Cordless Telescopic Pole Saw

Gergaji Rantai Teleskopik Tanpa Kord
充电式无刷伸缩式高枝链锯



- The chain speed is the same or higher than competing models, enabling comfortable cutting

Standard Equipment: Saw Chain, Guide Bar, Guide Bar Case, Wrench, Band Assembly (191K37-5), Hex Wrench, Round File, Safety Goggles (195246-2), Chain Oil

- ZB: Without Charger & Battery



Guide Bar Length Panjang Bar Panduan 导板长度	300mm (12")
Max Output Keluaran Maksima 最大输出	Normal Mode: 1,000W Torque Boost Mode: 1,400W
Oil Tank Capacity Tangki Minyak Pelincir 链油箱	160mL
Saw Chain Rantai 链条	Gauge: 1.1 / 1.3mm (0.043 / 0.050") Pitch: 9.5mm (3/8") 0 - 20.0m/s (0 - 1,200m/min)
Chain Speed Kelajuan Rantai 链条速度	(0 - 3,940FPM)
Dimensions (L x W x H) Dimensi 体积	2,826-4,058x155x191mm (111-160x6-1/8x7-1/2")
Net Weight Berat Bersih 净重	7.8 - 8.5kg (17.2 - 18.7lbs.)
Work Amount (approx.) Jumlah Kerja 工作量	238 cuts with BL1860B x2 100 x 100 Cedar square timber

* All list price shown are for reference only (exclude SST).

* Semua harga yang ditunjukkan adalah untuk rujukan sahaja (tidak termasuk SST). 所有显示的建议零售价仅供参考 (不包括SST)。

Cordless Target Kord 无绳
LED Flashlight Lampu Suluh LED LED 照明灯
Vacuum Cleaner Pemilauhi VAKUM 吸尘器
Drilling / Fastening Druai / Penamok 钻孔 / 紧固
Impact Drilling / Demolition Druai / Penamok 冲击钻孔 / 拆除加工
Cutting Pemotong 切割
Grinding / Sanding Pengisar / Poles 研磨 / 打磨
Sawing / Chaining Gergaji 锯切
Planting / Routing Pengisar / Tangkapan 切割 / 捆扎
Others Lain-lain 其他
Outdoor Power Equipment Alatan Kerja Luar 户外动力工具





Li-ion Ah 6.0 5.0 4.0 3.0 2.0 1.5

DUA300ZB

Cordless Pole Saw
Gergaji Rantai Teleskopik Tanpa Kord
充电式无刷高枝链锯



- The chain speed is the same or higher than competing models, enabling comfortable cutting

Standard Equipment:
Saw Chain, Guide Bar, Guide Bar Case, Wrench, Band Assembly (191K37-5), Round File, Safety Goggles (195246-2), Chain Oil

ZB: Without Charger & Battery



Guide Bar Length Panjang Bar Panduan 导板长度	300mm (12")
Max Output Keluaran Maksima 最大输出	Normal Mode: 1,000W Torque Boost Mode: 1,400W
Oil Tank Capacity Tangki Minyak Pelincir 链油箱	160mL
Saw Chain Rantai 链条	Gauge: 1.1 / 1.3mm (0.043 / 0.050") Pitch: 9.5mm (3/8")
Chain Speed Kelajuan Rantai 链条速度	0 - 20.0m/s (0 - 1,200m/min) (0 - 3,940FPM)
Dimensions (L x W x H) Dimensi 体积	2,478x155x191mm (97-1/2x6-1/8x7-1/2")
Net Weight Berat Bersih 净重	6.1 - 6.9kg (13.5 - 15.2lbs.)
Work Amount (approx.) Jumlah Kerja 工作量	238 cuts with BL1860B x2 100 x 100 Cedar square timber

DUC406Z 400mm (16")

Cordless Chain Saw
Gergaji Rantai Tanpa Kord
充电式链锯



- Low noise level and zero emissions for operator comfort

Standard Equipment: Saw Chain, Guide Bar, Guide Bar Cover, Chain Oil, Socket Wrench

Z: Without Charger & Battery



Guide Bar Length Panjang Bar Panduan 导板长度	400mm (16")
Chain Pitch Kerapatan Rantai 链条齿距	9.5mm (3/8")
Chain Gauge Ketebalan Rantai 链条厚度	1.3mm (0.05")
Chain Speed Kelajuan Rantai 链条速度	0 - 20m/s (0 - 1,200 m/min) (0 - 3,940 FPM)
Chain Oil Tank Volume Tangki Minyak Pelincir 链油箱	200mL (6.8US oz)
Dimensions (L x W x H) Dimensi 体积	270-651x205x232mm (10-5/8"-25-5/8"x8-1/8"x9-1/8")
Net Weight Berat Bersih 净重	5.1kg (11.1lbs.)
Work Amount (approx.) Jumlah Kerja 工作量	500 cuts with BL1850B x2 50 x 50 mm Cedar timber

DUC356Z 350mm (14")

Cordless Chain Saw
Gergaji Rantai Tanpa Kord
充电式链锯



- Low noise level and zero emissions for operator comfort

Standard Equipment: Saw Chain, Guide Bar, Guide Bar Cover, Spike Bumper, Chain Oil, Socket Wrench

Z: Without Charger & Battery



Guide Bar Length Panjang Bar Panduan 导板长度	350mm (14")
Chain Pitch Kerapatan Rantai 链条齿距	9.5mm (3/8")
Chain Gauge Ketebalan Rantai 链条厚度	1.1(0.043") or 1.3mm (0.050")
Chain Speed Kelajuan Rantai 链条速度	0 - 20m/s (0 - 1,200 m/min) (0 - 3,940 FPM)
Chain Oil Tank Volume Tangki Minyak Pelincir 链油箱	200mL (6.8US oz)
Dimensions (L x W x H) Dimensi 体积	270-651x205x232mm (10-5/8"-25-5/8"x8-1/8"x9-1/8")
Net Weight Berat Bersih 净重	5.1kg (11.1lbs.)
Work Amount (approx.) Jumlah Kerja 工作量	500 cuts with BL1850B x2 50 mm Timber

DUC355Z 350mm (14")

Cordless Chain Saw
Gergaji Rantai Tanpa Kord
充电式链锯



- Constant speed control maintains constant speed under heavy load

Standard Equipment: Saw Chain, Guide Bar, Guide Bar Cover, Chain Oil, Socket Wrench

Z: Without Charger & Battery



Guide Bar Length Panjang Bar Panduan 导板长度	350mm (14")
Chain Pitch Kerapatan Rantai 链条齿距	9.5mm (3/8")
Chain Gauge Ketebalan Rantai 链条厚度	1.1mm (0.043")
Chain Speed Kelajuan Rantai 链条速度	0 - 20m/s (0 - 1,200m/min) (0 - 3,940 FPM)
Chain Oil Tank Volume Tangki Minyak Pelincir 链油箱	200mL (6.8US oz)
Dimensions (L x W x H) Dimensi 体积	762x211x235mm (30"x8-5/16"x9-1/4")
Net weight Berat Bersih 净重	4.7 - 5.4kg (10.4 - 11.8lbs.)
Work Amount (approx.) Jumlah Kerja 工作量	550 cuts with BL1850B x2 50 mm Timber

DUC353Z 350mm (14")

Cordless Chain Saw
Gergaji Rantai Tanpa Kord
充电式链锯



- Cordless Chain Saw DUC353 Efficiency Similar to 30ml Class Engine Chain Saw

Standard Equipment: Saw Chain, Guide Bar, Guide Bar Cover, Chain Oil

Z: Without Charger & Battery



Guide Bar Length Panjang Bar Panduan 导板长度	350mm (14")
Chain Pitch Kerapatan Rantai 链条齿距	9.5mm (3/8")
Chain Gauge Ketebalan Rantai 链条厚度	1.1 (0.043") or 1.3mm (0.050")
Chain Speed Kelajuan Rantai 链条速度	0 - 20m/s (0 - 1,200m/min) (0 - 3,940FPM)
Chain Oil Tank Volume Tangki Minyak Pelincir 链油箱	200mL (6.8US oz)
Dimensions (L x W x H) Dimensi 体积	773x215x235mm (30-1/2"x8-1/2"x9-1/4")
Net Weight Keberatan 净重	4.7kg (10.4 lbs)
Work Amount (approx.) Jumlah Kerja 工作量	550 cuts with BL1850B x2 50 mm Timber

* All list price shown are for reference only (exclude SST).

* Semua harga yang ditunjukkan adalah untuk rujukan sahaja (tidak termasuk SST). 所有显示的建议零售价仅供参考 (不包括SST)。

Cordless
Targeted Jobs

LED Flashlight
Lampu Suhu LED
LED 手电筒

Vacuum Cleaner
Pembersih Vakum
吸尘器

Drilling / Fastening
Gergaji / Pengikat
钻孔 / 紧固

Impact Drilling / Demolition
Gergaji / Pemusnah
冲击钻孔 / 拆除施工

Cutting
Pemotong
切割

Grinding / Sanding
Pengkilat / Poles
研磨 / 打磨

Sawing
Gergaji
锯切

Planing / Routing
Pengkilat / Tanggam
刨削 / 雕刻

Others
Lain-lain
其他

Outdoor Power Equipment
Alatan Kuat Luar
园机 / 户外





Li-ion Ah 6.0 5.0 4.0 3.0 2.0 1.5

DUC252Z 250mm (10")

442

Cordless Chain Saw
Gergaji Rantai Tanpa Kord
充电式链锯



- Low noise level and zero emissions for operator comfort

Standard Equipment: Saw Chain (196205-9), Guide Bar (168408-5), Guide Bar Cover (455284-9), Spike Bumper

- Z: Without Charger & Battery



Guide Bar Length Panjang Bar Panduan 导板长度	250mm (10")
Chain Pitch Kerapatan Rantai 链条齿距	9.5mm (3/8")
Chain Gauge Ketebalan Rantai 链条厚度	1.3mm (0.050")
Chain Speed Kelajuan Rantai 链条速度	8.3m/s (500m/min) (1,650FPM)
Chain Oil Tank Volume Tangki Minyak Pelincir 链油箱	85mL (2.9US oz)
Dimensions (L x W x H) Dimensi 体积	545x234x198mm (21-1/2"x9-1/4"x7-3/4")
Net Weight Keberatan 净重	4.1 - 4.7kg (9.0 - 10.3lbs)
Work Amount (approx.) Jumlah Kerja 工作量	560 cuts with BL1850B x2 50 mm Timber

Model	Standard Equipment					Optional Accessories					
	Guide Bar		Saw Chain		Bar Cover	Guide Bar		Saw Chain		Bar Cover	Drive Sprocket
DUA301/ DUA300	30cm/ 12" sprocket nose bar	165200-0	12"/ 1.3mm/ 0.050" 3/8" 46Links	196206-7	419288-5	30cm/ 12" sprocket nose bar	191G23-2	12"/ 1.3mm/ 0.050" 3/8" 46Links	196206-7	419288-5	226992-7
DUC406	40cm/ 16" Sprocket nose bar	165247-4	16"/ 1.1mm/ 0.043" 3/8" 56Links	196742-3	419242-9	40cm/ 16" Sprocket nose bar	191G17-7	16"/ 1.1mm/ 0.043" 3/8" 56Links	196742-3	419242-9	199063-2
DUC356/ DUC355/ DUC353	35cm/ 14" Sprocket nose bar	165246-6	14"/ 1.1mm/ 0.043" 3/8" 46Links	196741-5	419288-5	35cm/ 14" Sprocket nose bar	191G16-9	14"/ 1.1mm/ 0.043" 3/8" 46Links	196741-5	419288-5	199063-2
DUC254	25cm/ 10" sprocket nose bar	161846-0	10"/ 1.1mm/ 0.043" 3/8" 40Links	199075-5	458501-6	25cm/ 10" sprocket nose bar	191G14-3	10"/ 1.1mm/ 0.043" 3/8" 40Links	199075-5	458501-6	199063-2

DUH651Z 650mm (25-1/2")

442

Cordless Hedge Trimmer
Pemangkas Tanaman Pagar
Tanpa Kord
充电式篱笆修剪



- 5-Position rotating rear handle for increased comfort during vertical and angle trimming

Standard Equipment: Blade Cover

- Z: Without Charger & Battery



Blade Length Panjang bilah 刀片长度	650mm (25-1/2")
Strokes Per Minute (SPM) Kelajuan Strok 冲程速度	2,000 - 3,600
Tooth Spacing Selang Gigi 牙齿间隔	36mm (1-7/16")
Dimensions (L x W x H) Dimensi 体积	1,135x225x200mm (44-3/4"x8-7/8"x7-7/8")
Net Weight Keberatan 净重	4.7 - 5.5kg (10.3 - 12.0lbs)
Continuous Usage Time (approx.) Masa Penggunaan Berterusan 连续使用时间	75 - 125 min with BL1850B x2

DUB363ZV

Cordless Blower
Mesin Penghembus Angin
Tanpa Kord
充电式吹风机



- Able to use both in Blower and Vacuuming applications

Standard Equipment: Vacuum Kit, End Nozzle, Pipe, Hex Wrench

- ZV: Without Charger & Battery



Max Air Volume Isipadu Angin Maksimum 最大风量	13.4m³/min (473 CFM)
Max Air Velocity Velositi Angin Maksimum 最大风速	65m/s
No Load Speed (RPM) Kelajuan Tanpa Beban 回转数	0 - 7,850
Dimensions (L x W x H) Dimensi 体积	737/786/836x193x415mm (29-1/8"/31-1/8"/33-1/8"x7-7/8"/16-3/8")
Net Weight Berat Bersih 净重	4.5 - 6.6kg (9.9 - 14.6lbs.)
Continuous Usage Time (approx.) Masa Penggunaan Berterusan 连续使用时间	75 min (Mode 1) 9.5 min (Mode 2) with BL1860B x2



DUB362RT2 | DUB362RM2 | DUB362Z

Cordless Blower
Mesin Penghembus Angin
Tanpa Kord
充电式吹风机



- 6-stage air velocity/volume selection dial with variable speed control trigger

Standard Equipment: Front Nozzle (455914-2)

- RT2: 1x Rapid Charger, 2x 5.0Ah Battery
- RM2: 1x Rapid Charger, 2x 4.0Ah Battery
- Z: Without Charger & Battery



Max Air Volume Isipadu Angin Maksimum 最大风量	13.4m³/min (473CFM)
Max Air Velocity Velositi Angin Maksimum 最大风速	54m/s (120MPH)
No Load Speed (RPM) Kelajuan Tanpa Beban 回转数	11,400 - 21,500
Dimensions (L x W x H) Dimensi 体积	830/880/930x205x295mm (32-3/4"/34-3/4"/36-5/8"x8-1/8"x11-5/8")
Net Weight Berat Bersih 净重	3.5 - 4.2kg (7.7 - 9.3lbs)
Continuous Usage Time (approx.) Masa Penggunaan Berterusan 连续使用时间	75 min with BL1850B x2 (Speed 1)

* All list price shown are for reference only (exclude SST).

* Semua harga yang ditunjukkan adalah untuk rujukan sahaja (tidak termasuk SST). 所有显示的建议零售价仅供参考 (不包括SST)。

Cordless
Target Kord 无绳式

LED Flashlight
Lampu Suluh LED
LED 照明灯

Vacuum Cleaner
Pembersih Vakuum
吸尘器

Drilling / Fastening
Gergaji / Pengikat
钻孔 / 紧固

Impact Drilling / Demolition
Gergaji / Penanggal
冲击钻孔 / 拆除加工

Cutting
Pemotong
切割

Grinding / Sanding
Pengisar / Piskin
磨削 / 打磨

Sawing
Gergaji
锯切

Planing / Routing
Pengisar / Tangkapan
刨削 / 雕刻

Others
Lain-lain
其他

Outdoor Power Equipment
Alatan Kerja Luar
园具-户外

Makita
Makita



Li-ion Ah 6.0 5.0 4.0 3.0 2.0 1.5

DUB361Z

430 mm

Cordless Blower

Mesin Penghembus Angin Tanpa Kord
充电式吹风机



- Long blowing nozzle with curved tip for optimal blowing performance

Standard Equipment: Shoulder Belt, Nozzle

• Z: Without Charger & Battery



Max Air Volume Isipadu Angin Maksimum 最大风量	High: 4.4m ³ /min (155CFM) Low: 2.6m ³ /min (92CFM)
Max Air Velocity Velosti Angin Maksimum 最大风速	High: 93m/s (208MPH) Low: 57m/s (128MPH)
No Load Speed (RPM) Kelajuan Tanpa Beban 回转数	High: 17,000 Low: 10,000
Dimensions (L x W x H) Dimensi 体积	905x141x194mm (35-5/8"x5-5/8"x7-5/8")
Net Weight Berat Bersih 净重	2.6kg (5.9lbs)
Continuous Usage Time (approx.) Masa Penggunaan Berterusan 连续使用时间	Low: 92 min High: 30 min with BL1850B x2

DDG460 Cordless Earth Auger



Reversing switch
enables to extract, in reverse rotation mode, an auger bit jammed in soil with high resistance like clay soil.

Torque limiter
The torque limiter will actuate when a certain torque level is reached at the low speed setting. The motor will disengage from the output shaft. When this happens, the drill bit will stop turning.



Light weight
8.2kg
with BL1860B x2
6.0Ah Battery

Work Amount
with BL1860 x2
(ø150mm, 600mm depth)

155 holes
(approx.)



DDG460ZX7

Cordless Earth Auger

Mesin Gerudi Tanah Tanpa Kord
充电式弯角度地钻头



- Auger bit adapter enables to use the auger bits for popular engine earth augers

Standard Equipment:
Chuck Key, Hex Wrench x3 Types,
Adapter A (327684-2),
Adapter D (327687-6), Handle Set

• ZX7: Without Charger & Battery



Come with



Adapter A (327684-2) Adapter D (327687-6)

Capacity Kapasiti 能力	Sandy Soil: 200mm Clay Soil: 150mm
Chuck Capacity Kapasiti Chuck 夹头能力	2 - 13mm (5/64 - 1/2")
No Load Speed (RPM) Kelajuan Tanpa Beban 回转数	High: 0 - 1,400 Low: 0 - 350
Max Fastening Torque Pemutaran Tenaga Maksimum 最大扭矩	High: 48N-m (430in.lbs.) Low: 136N-m (1,210in.lbs.)
Dimensions (L x W x H) Dimensi 体积	840x607x223mm (33x23-7/8x8-3/4")
Net Weight Berat Bersih 净重	7.3 - 8.2kg (16.1 - 18.1lbs.)
Work Amount (approx.) Jumlah Kerja 工作量	155 holes with BL1860B x2 ø150 mm, 600 mm depth

* All list price shown are for reference only (exclude SST).

* Semua harga yang ditunjukkan adalah untuk rujukan sahaja (tidak termasuk SST). 所有显示的建议零售价仅供参考 (不包括SST)。

- Cordless Targeted Jobs
- LED Flashlight Lampu Suhu LED LED 闪光灯
- Vacuum Cleaner Pembersih Vakuum 吸尘器
- Drilling / Fastening Gerudi / Pengikat 钻孔 / 紧固
- Impact Drilling / Demolition Gerudi / Penusuk 冲击钻孔 / 拆除施工
- Cutting Pemotong 切割
- Grinding / Sanding Pengkilan / Poles 打磨 / 抛光
- Sawing Gergaji 锯切
- Planing / Routing Pengkilan / Tunggam 刨削 / 雕刻
- Others Lain-lain 其他
- Outdoor Power Equipment Alatan Kuat Luar 户外动力工具





Li-ion Ah 6.0 5.0 4.0 3.0 2.0 1.5

DHW080 Cordless High Pressure Washer

Accessories (Optional)

Cyclone jet nozzle set (Optional)
Part No. 197824-4

Trigger gun set
Part No. 197842-2

High pressure extension hose (Optional)
Part No.
5m 197845-6
8m 197847-2
10m 197850-3

Cyclone guard set (Optional)
Part No. 197864-2

Extension pipe set (Optional)
Part No. 197870-7

High pressure hose (Optional)
Part No.
5m 126766-5 (PVC)
10m 123784-4 (PVC)
10m 123651-3 (Rubber)

Variospray lance set (Optional)
Part No. 197876-5

Twist prevention joint set (Optional)
Part No. 197867-6

Trolley (Optional)
Part No. TR00000002
able to stack on for easy loading

Foam nozzle set (Optional)
Part No. 197886-2

Wash brush set (Optional)
Part No. 197828-6

Variable nozzle set
Part No. 197822-8

Rotating brush set (Optional)
Part No. 197831-7

Under body spray lance set (Optional)
Part No. 197859-5

Absorption connector set (Optional)
Part No. 197881-2

One touch joint set
Part No. 197883-8

Pipe cleaning hose (Optional)
Part No.
10m 197837-5
15m 197840-6

Self-suction hose set
Part No. 197873-1

Accessory joint set (Optional)
Part No. 197853-7

DHW080ZK

Cordless High Pressure Washer
Pembersih Tekanan Tinggi
Tanpa Kord
充电式高压清洗机



- High/ Low 2-pressure selection

Standard Equipment: Trigger Gun, High Pressure Hose 5m, Suction Hose, Cleaner Pin, Storage Box, Variable Nozzle, Connector, One Touch Joint

- ZK: Without Charger & Battery



Max Permissible Pressure Tekanan Maksimum 最大水压	8.0MPa
Regular Pressure Tekanan Tetap 固定压力	High: 5.5MPa Low: 3.0MPa
Max Water Flow Aliran Air Maksimum 最大水流量	380L/h (6.3L/min)
Regular Flow Aliran Air Tetap 固定水流量	High: 330L/h (5.5L/min) Low: 240L/h (4.0L/min)
Pump Speed (RPM) Kelajuan Pam 水泵速度	High: 3,450 Low: 2,390
Max Feed Temperature Suhu Maksimum 最高温度	40°C
Tank Kapasiti 容量	50L
Dimensions (L x W x H) Dimensi 体积	438x218x269mm (17-1/4"x8-5/8"x10-5/8")
Net Weight Berat Bersih 净重	7.1 - 7.7kg (15.6 - 17.0lbs.)
Continuous Usage Time (approx.) Masa Penggunaan Berterusan 连续使用时间	Low: 34 min High: 15 min with BL1860B x2

* All list price shown are for reference only (exclude SST).

* Semua harga yang ditunjukkan adalah untuk rujukan sahaja (tidak termasuk SST). 所有显示的建议零售价仅供参考 (不包括SST)。

Cordless
Target Model 无绳式

LED Flashlight
Lampu Suling LED
LED 照明灯

Vacuum Cleaner
Pembersih Vakuum
吸尘器

Drilling / Fastening
Dremel / Pengikat
钻头 / 螺絲

Impact Drilling / Demolition
Garuhi / Perseki
冲击钻 / 拆墙加工

Cutting
Dagang
切割

Grinding / Sanding
Pengisar / Pasir
磨削 / 砂纸

Sawing
Dagang
切割

Planing / Routing
Pengaram / Tampam
刨削 / 磨床

Outdoor Power Equipment
Alatan Korsa Luar
园机 / 户外

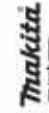

18V

LXT

Li-ion Ah 6.0 5.0 4.0 3.0 2.0 1.5

DDF486 Cordless Driver Drill



Max Lock Torque
125 N·m



BL MOTOR
XPT

DDF486RTE | DDF486Z 13mm (1/2")

Cordless Driver Drill
Gerudi Pemutar Skru Tanpa Kord
充电式螺丝起子电钻



- Increased performance in continuous heavy-duty applications

Standard Equipment: Side Handle, Belt Clip, (+)(-) Bit, Bit Holder

- RTE: 1x Rapid Charger, 2x 5.0Ah Battery
- Z: Without Charger, Battery & Carrying Case



Not applicable for Z model
BL MOTOR XPT

DDF481RTE | DDF481RME | DDF481RFE | DDF481Z 13mm (1/2")

Cordless Driver Drill
Gerudi Pemutar Skru Tanpa Kord
充电式螺丝起子电钻



- 21 Clutch settings and drill mode for added fastening control

Standard Equipment: Side Grip, Belt Clip, (+)(-) Bit, Bit Holder

- RTE: 1x Rapid Charger, 2x 5.0Ah Battery
- RME: 1x Rapid Charger, 2x 4.0Ah Battery
- RFE: 1x Rapid Charger, 2x 3.0Ah Battery
- Z: Without Charger, Battery & Carrying Case



Not applicable for Z model
BL MOTOR XPT

Capacity Kapasiti 能力	Steel: 13mm (1/2") Wood (Auger-Bit): 50mm (2") Wood (Hole Saw): 152mm (6") Siding Board: 170mm (6-11/16") High: 0 - 2,100 Low: 0 - 550
No Load Speed (RPM) Kelajuan Tanpa Beban 回转数	
Max Fastening Torque Tenaga Pemutaran Pancingan Maksimum 最大紧固扭力	Hard: 130N-m (1,150in.lbs.) Soft: 65N-m (580in.lbs.)
Max Lock Torque Pemutaran Tenaga Maksimum 最大锁紧扭力	125N-m (1,100in.lbs.)
Dimensions (L x W x H) Dimensi 体积	178x81x265mm (7x3-3/16x10-3/8")
Net Weight Berat Bersih 净重	2.3 - 2.6kg (5.1 - 5.7lbs.)
Work Amount (approx.) Jumlah Kerja 工作量	710 holes with BL1850B Wood bit ø21mm (30mm thick melapi) High Speed

Capacity Kapasiti 能力	Steel: 13mm (1/2") Wood: 76mm (3") 1.5 - 13mm (1/16 - 1/2")
Chuck Capacity Kapasiti Chuck 夹头能力	
No Load Speed (RPM) Kelajuan Tanpa Beban 回转数	High: 0 - 2,100 Low: 0 - 550
Max Fastening Torque Maksimum Tenaga Pemutaran Pancingan 最大紧固扭力	Hard: 115N-m (1,020in.lbs.) Soft: 60N-m (530in.lbs.)
Max Lock Torque Pemutaran Tenaga Maksimum 最大锁紧扭力	125N-m (1,090in.lbs.)
Max Output Keluaran Maksimum 最大输出	640W
Dimensions (L x W x H) Dimensi 体积	205x79x266mm (8-1/8"x3-1/8"x10-1/2")
Net Weight Berat Bersih 净重	2.7 - 3.0kg (5.9 - 6.6lbs)
Work Amount (approx.) Jumlah Kerja 工作量	630 holes with BL1850B Wood bit ø21mm (25mm thick Lauan)

* All list price shown are for reference only (exclude SST).

* Semua harga yang ditunjukkan adalah untuk rujukan sahaja (tidak termasuk SST). 所有显示的建议零售价仅供参考 (不包括SST)。

Cordless
Tanpa Kord 无绳

LED Flashlight
Lampu Suhu LED
LED照明灯

Vacuum Cleaner
Pembersih Vakum
吸尘器

Drilling / Fastening
Geri / Pengat
钻孔 / 紧固

Impact Drilling / Demolition
Geri / Penusuk
冲击钻孔 / 拆卸

Cutting
Pemotong
切割

Grinding / Sanding
Pengkil / Pemoles
研磨 / 打磨

Sawing
Gergaji
锯切

Planing / Routing
Pengalun / Tunggau
刨削 / 雕刻

Others
Lain-lain
其他

Outdoor Power Equipment
Alatan Kuat Luar
园机 / 户外

Makita
1000000000

18V

LXT

Li-ion Ah 6.0 5.0 4.0 3.0 2.0 1.5

DDF458RME | DDF458RFE | DDF458Z 13mm (1/2")

440 W

Cordless Driver Drill

Gerudi Pemutar Skru Tanpa Kord
充电式螺丝起子电钻

- Mechanical 2-speed transmission covers a wide range of drilling and fastening applications

Standard Equipment: Side Grip, (+)(-) Bit, Belt Clip, Bit Holder

- RME: 1x Rapid Charger, 2x 4.0Ah Battery
- RFE: 1x Rapid Charger, 2x 3.0Ah Battery
- Z: Without Charger, Battery & Carrying Case



*Not applicable for Z model

XPT

DDF482RME | DDF482RFE | DDF482Z 13mm (1/2")

440 W

Cordless Driver Drill

Gerudi Pemutar Skru Tanpa Kord
充电式螺丝起子电钻

- High speed model with compact and lightweight design

Standard Equipment: Belt Clip, (+)(-) Bit

- RME: 1x Rapid Charger, 2x 4.0Ah Battery
- RFE: 1x Rapid Charger, 2x 3.0Ah Battery
- Z: Without Charger, Battery & Carrying Case



*Not applicable for Z model

XPT

DDF484RTE | DDF484RME | DDF484RFE | DDF484Z 13mm (1/2")

Cordless Driver Drill

Gerudi Pemutar Skru Tanpa Kord
充电式螺丝起子电钻

- Delivers 25% more drilling, driving and fastening speed

Standard Equipment: Belt Clip, (+)(-) Bit

- RTE: 1x Rapid Charger, 2x 5.0Ah Battery
- RME: 1x Rapid Charger, 2x 4.0Ah Battery
- RFE: 1x Rapid Charger, 2x 3.0Ah Battery
- Z: Without Charger, Battery & Carrying Case



*Not applicable for Z model

BL MOTOR XPT

DDF485RFE | DDF485Z 13mm (1/2")

Cordless Driver Drill

Gerudi Pemutar Skru Tanpa Kord
充电式螺丝起子电钻

- Variable 2-speed for a wide range of drilling and fastening applications

Standard Equipment: Belt Clip, (+)(-) Bit

- RFE: 1x Rapid Charger, 2x 3.0Ah Battery
- Z: Without Charger, Battery & Carrying Case



*Not applicable for Z model

BL MOTOR XPT

DDF459RME | DDF459Z 13mm (1/2")

Cordless Driver Drill

Gerudi Pemutar Skru Tanpa Kord
充电式螺丝起子电钻

- Brushless motor delivers up to 50% longer run time per charge

Standard Equipment: Belt Clip, (+)(-) Bit

- RME: 1x Rapid Charger, 2x 4.0Ah Battery
- Z: Without Charger, Battery & Carrying Case



*Not applicable for Z model

BL MOTOR

Capacity Kapasiti 能力	Steel: 13mm (1/2") Wood: 76mm (3")
No Load Speed (RPM) Kelajuan Tanpa Beban 回转数	High: 0-2,000 Low: 0-400
Max Fastening Torque Maksimum Tenaga Pemutaran Pengancing 最大紧固扭力	Hard: 91N·m Soft: 58N·m
Max Lock Torque Pemutaran Tenaga Maksimum 最大锁紧扭力	84N·m (750in.lbs.)
Dimensions (L x W x H) Dimensi 体积	225x79x259mm (8-7/8"x3-1/8"x10-1/4")
Net Weight Berat Bersih 淨重	2.1 - 2.5kg (4.7 - 5.4lbs)
Work Amount (approx.) Jumlah Kerja 工作量	500 holes with BL1850B Wood bit ø21mm (25mm thick Lauan)

Capacity Kapasiti 能力	Steel: 13mm (1/2") Wood: 38mm (1-1/2")
Chuck Capacity Kapasiti Chuck 夹头能力	1.5 - 13mm (1/16 - 1/2")
No Load Speed (RPM) Kelajuan Tanpa Beban 回转数	High: 0 - 1,900 Low: 0 - 600
Max Fastening Torque Maksimum Tenaga Pemutaran Pengancing 最大紧固扭力	Hard: 62N·m (550in.lbs.) Soft: 36N·m (320in.lbs.)
Max Lock Torque Pemutaran Tenaga Maksimum 最大锁紧扭力	54N·m (480in.lbs.)
Dimensions (L x W x H) Dimensi 体积	185x79x249mm (7-1/4"x3-1/8"x9-3/4")
Net Weight Berat Bersih 淨重	1.5 - 1.8kg (3.2 - 4.0lbs)
Work Amount (approx.) Jumlah Kerja 工作量	781 holes with BL1850B Brad Point Wood bit ø8mm (1" Depth Mixed wood)

Capacity Kapasiti 能力	Steel: 13mm (1/2") Wood: 38mm (1-1/2")
Chuck Capacity Kapasiti Chuck 夹头能力	1.5 - 13mm (1/16 - 1/2")
No Load Speed (RPM) Kelajuan Tanpa Beban 回转数	High: 0 - 2,000 Low: 0 - 500
Max Fastening Torque Maksimum Tenaga Pemutaran Pengancing 最大紧固扭力	Hard: 54N·m (480in.lbs.) Soft: 30N·m (270in.lbs.)
Max Lock Torque Pemutaran Tenaga Maksimum 最大锁紧扭力	60N·m (530in.lbs.)
Dimensions (L x W x H) Dimensi 体积	172x79x261mm (6-3/4"x3-1/8"x10-1/4")
Net Weight Berat Bersih 淨重	1.5 - 1.8kg (3.3 - 4.0lbs)
Work Amount (approx.) Jumlah Kerja 工作量	1550 holes with BL1850B Wood bit ø9mm (30mm thick Lauan)

Capacity Kapasiti 能力	Steel: 13mm (1/2") Wood: 38mm (1-1/2")
Chuck Capacity Kapasiti Chuck 夹头能力	1.5 - 13mm (1/16 - 1/2")
No Load Speed (RPM) Kelajuan Tanpa Beban 回转数	High: 0 - 1,900 Low: 0 - 500
Max Fastening Torque Maksimum Tenaga Pemutaran Pengancing 最大紧固扭力	Hard: 50N·m (440in.lbs.) Soft: 27N·m (240in.lbs.)
Max Lock Torque Pemutaran Tenaga Maksimum 最大锁紧扭力	50N·m (440in.lbs.)
Max Output Keluaran Maksima 最大输出	350W
Clutch Torque Setting Tetapan Pemutaran 扭转设置	1.0 - 5.0N·m (9 - 44in.lbs.)
Dimensions (L x W x H) Dimensi 体积	169x79x255mm (7-1/8"x3-1/8"x10")
Net Weight Berat Bersih 淨重	1.4 - 1.7kg (3.1 - 3.8lbs.)
Work Amount (approx.) Jumlah Kerja 工作量	1400 pcs with BL1850B Auger Bit ø15mm (30mm thick Melapi)

Capacity Kapasiti 能力	Steel: 13mm (1/2") Wood: 38mm (1-1/2")
Chuck Capacity Kapasiti Chuck 夹头能力	1.5 - 13mm (1/16 - 1/2")
No Load Speed (RPM) Kelajuan Tanpa Beban 回转数	High: 0 - 1,500 Low: 0 - 400
Max Fastening Torque Maksimum Tenaga Pemutaran Pengancing 最大紧固扭力	Hard: 45N·m (400in.lbs.) Soft: 25N·m (220in.lbs.)
Max Lock Torque Pemutaran Tenaga Maksimum 最大锁紧扭力	45N·m (400in.lbs.)
Dimensions (L x W x H) Dimensi 体积	179x78x256mm (7"x3-1/16"x10-1/8")
Net Weight Berat Bersih 淨重	1.4 - 1.7kg (3.1 - 3.8lbs)
Work Amount (approx.) Jumlah Kerja 工作量	1470 pcs with BL1850B Auger Bit ø15mm (30mm thick Melapi)

* All list price shown are for reference only (exclude SST).

* Semua harga yang ditunjukkan adalah untuk rujukan sahaja (tidak termasuk SST). 所有显示的建议零售价仅供参考 (不包括SST)。

18V

LXT

Li-ion Ah 6.0 5.0 4.0 3.0 2.0 1.5

DDF453RME | DDF453RFE | DDF453SYE | DDF453Z 13mm (1/2")

Cordless Driver Drill
Gerudi Pemutar Skru Tanpa Kord
充电式螺丝起子电钻



- All metal gear construction ensures high transmission durability

Standard Equipment: (+)(-) Bit

- RME: 1x Rapid Charger, 2x 4.0Ah Battery
- RFE: 1x Rapid Charger, 2x 3.0Ah Battery
- SYE: 1x Standard Charger, 2x 1.5Ah Battery
- Z: Without Charger, Battery, Bit & Carrying Case



Capacity Kapasiti 能力	Steel: 13mm (1/2") Wood: 36mm (1-7/16")
No Load Speed (RPM) Kelajuan Tanpa Beban 回转数	High: 0-1,300 Low: 0-400
Max Fastening Torque Maksimum Tenaga Pemutaran Pengancing 最大紧固扭力	Hard: 42N-m Soft: 27N-m
Max Lock Torque Pemutaran Tenaga Maksimum 最大锁紧扭力	38N-m (340in.lbs.)
Dimensions (L x W x H) Dimensi 体积	222x79x244mm (8-3/4"x3-1/8"x9-5/8")
Net Weight Berat Bersih 净重	1.7 - 2.0kg (3.7 - 4.4lbs)
Work Amount (approx.) Jumlah Kerja 工作量	720 pcs with BL1850B Wood screw ø4.1 x 38mm

DDF487RAJ | DDF487Z 13mm (1/2")

Cordless Driver Drill
Gerudi Pemutar Skru Tanpa Kord
充电式螺丝起子电钻



- Compact design at only 150 mm long for increased operability

Standard Equipment: Belt Clip, (+)(-) Bit

- RAJ: 1x Rapid Charger, 2x 2.0Ah Battery, 1x Makpac Connector Box
- Z: Without Charger, Battery & Carrying Case



Capacity Kapasiti 能力	Steel: 13mm (1/2") Wood (Hole Saw): 51mm (2") Wood (Self-Feed Bit): 35mm (1-3/8") Wood (Auger Bit): 36mm (1-7/16")
No Load Speed (RPM) Kelajuan Tanpa Beban 回转数	High: 0 - 1,700 Low: 0 - 500
Max Fastening Torque Maksimum Tenaga Pemutaran Pengancing 最大紧固扭力	Hard: 40N-m (350in.lbs.) Soft: 25N-m (220in.lbs.)
Max Lock Torque Pemutaran Tenaga Maksimum 最大锁紧扭力	40N-m (350in.lbs.)
Dimensions (L x W x H) Dimensi 体积	150x81x248mm (5-7/8"x3-1/16"x9-3/4")
Net Weight Berat Bersih 净重	1.3 - 1.6kg (2.9 - 3.5lbs.)
Work Amount (approx.) Jumlah Kerja 工作量	640 holes with BL1820B Wood bit ø9mm (30mm thick melapi) High Speed

DDF483RME | DDF483RFE | DDF483Z 13mm (1/2")

Cordless Driver Drill
Gerudi Pemutar Skru Tanpa Kord
充电式螺丝起子电钻



- BL motor delivers 40N-m of max torque

Standard Equipment: Belt Clip, (+)(-) Bit

- RME: 1x Rapid Charger, 2x 4.0Ah Battery
- RFE: 1x Rapid Charger, 2x 3.0Ah Battery
- Z: Without Charger, Battery & Carrying Case



Capacity Kapasiti 能力	Steel: 13mm (1/2") Wood: 36mm (1-7/16")
Chuck Capacity Kapasiti Chuck 夹头能力	1.5 - 13mm (1/16 - 1/2")
No Load Speed (RPM) Kelajuan Tanpa Beban 回转数	High: 0 - 1,700 Low: 0 - 500
Max Fastening Torque Maksimum Tenaga Pemutaran Pengancing 最大紧固扭力	Hard: 40N-m (350in.lbs.) Soft: 23N-m (210in.lbs.)
Max Lock Torque Pemutaran Tenaga Maksimum 最大锁紧扭力	40N-m (350in.lbs.)
Dimensions (L x W x H) Dimensi 体积	162x79x247mm (6-3/8"x3-1/8"x9-3/4")
Net Weight Berat Bersih 净重	1.2 - 1.6kg (2.7 - 3.4lbs)
Work Amount (approx.) Jumlah Kerja 工作量	1666 pcs with BL1850B Wood Bit ø9mm (30mm thick Lauan)

DDF083RTE | DDF083RFE | DDF083Z 13mm (1/2")

Cordless Driver Drill
Gerudi Pemutar Skru Tanpa Kord
充电式螺丝起子电钻



- Mechanical 2-speed transmission covers a wide range of drilling and fastening applications

Standard Equipment: Belt Clip, Phillips Bit

- RTE: 1x Rapid Charger, 2x 5.0Ah Battery
- RFE: 1x Rapid Charger, 2x 3.0Ah Battery
- Z: Without Charger, Battery & Carrying Case



Capacity Kapasiti 能力	Steel: 13mm (1/2") Wood: 36mm (1-7/16")
Chuck Capacity Kapasiti Chuck 夹头能力	6.35mm (1/4")
No Load Speed (RPM) Kelajuan Tanpa Beban 回转数	High: 0 - 1,700 Low: 0 - 500
Max Fastening Torque Maksimum Tenaga Pemutaran Pengancing 最大紧固扭力	Hard: 40N-m (350in.lbs.) Soft: 23N-m (210in.lbs.)
Max Lock Torque Pemutaran Tenaga Maksimum 最大锁紧扭力	40N-m (350in.lbs.)
Dimensions (L x W x H) Dimensi 体积	124x79x247mm (4-7/8"x3-1/8"x9-3/4")
Net Weight Berat Bersih 净重	1.1 - 1.4kg (2.4 - 3.0lbs)
Work Amount (approx.) Jumlah Kerja 工作量	1666 pcs with BL1850B Wood Bit ø9mm (30mm thick Lauan)

Model No. 型号	Capacity Kapasiti 能力		No Load Speed (rpm) Kelajuan Tanpa Beban 回转数	Mechanical Speed Mekanikal Kelajuan 机械速度	Torque Setting Tetapan Pemutaran 扭矩设置	Max. Fastening Torque Maksimum Tenaga Pemutaran Pengancing 最大紧固扭力	Overall Length (mm) Panjang Keseluruhan 总长度	Net Weight Berat Bersih 净重	BL MOTOR	XPT
	Steel	Wood								
DDF486	13mm	76mm	0-2,100 / 0-550	2 Speed	21	Hard: 130 / Soft: 65	178	2.3kg (5.1lbs)	●	●
DDF481	13mm	76mm	0-2,100 / 0-550	2 Speed	21	Hard: 115 / Soft: 60	205	2.7kg (5.9lbs)	●	●
DDF458	13mm	76mm	0-2,000 / 0-400	2 Speed	21	Hard: 91 / Soft: 58	225	2.1kg (4.7lbs)	●	●
DDF482	13mm	38mm	0 - 1,900 / 0 - 600	2 Speed	21	Hard: 62 / Soft: 36	185	1.5kg (3.2lbs)	●	●
DDF484	13mm	38mm	0-2,000 / 0-500	2 Speed	21	Hard: 54 / Soft: 30	172	1.5kg (3.3lbs)	●	●
DDF485	13mm	38mm	0-1,900 / 0-500	2 Speed	21	Hard: 50 / Soft: 27	169	1.4kg (3.1lbs)	●	●
DDF459	13mm	38mm	0-1,500 / 0-400	2 Speed	16	Hard: 45 / Soft: 25	179	1.4kg (3.1lbs)	●	●
DDF453	13mm	36mm	0-1,300 / 0-400	2 Speed	16	Hard: 42 / Soft: 27	222	1.7kg (3.7lbs)	●	●
DDF487	13mm	36mm	0-1,700 / 0-500	2 Speed	20	Hard: 40 / Soft: 25	150	1.3kg (2.9lbs)	●	●
DDF483	13mm	36mm	0-1,700 / 0-500	2 Speed	20	Hard: 40 / Soft: 23	162	1.2kg (2.7lbs)	●	●
DDF083	13mm	36mm	0-1,700 / 0-500	2 Speed	20	Hard: 40 / Soft: 23	124	1.1kg (2.4lbs)	●	●

* All list price shown are for reference only (exclude SST).

* Semua harga yang ditunjukkan adalah untuk rujukan sahaja (tidak termasuk SST). 所有显示的建议零售价仅供参考 (不包括SST)。

Cordless
Targeted Jobs

LED Flashlight
Lampu Suli LED
LED手电筒

Vacuum Cleaner
Pembersih Vakum
吸尘器

Drilling / Fastening
Gerudi / Pengancing
钻孔 / 紧固

Impact Drilling / Demolition
Gerudi / Penembak
冲击钻孔 / 破拆施工

Cutting
Pemotong
切割

Grinding / Sanding
Pengamiran / Pemoles
研磨 / 砂磨

Sawing
Gergaji
锯切

Planing / Routing
Pengaliran / Tunggam
刨削 / 压花

Others
Lain-lain
其他

Outdoor Power Equipment
Alatan Kuasa Luar
户外动力工具

Makita
18V LXT

Cordless
Target Kord 无绳式

LED Flashlight
Lampu Suluh LED
LED 照明灯

Vacuum Cleaner
Pembersih VAKUUM
吸尘器

Drilling / Fastening
Dremel / Pengikat
钻式 / 紧固

Impact Drilling / Demolition
Gerudi / Perseksi
起工钻式 / 拆毁加工

Cutting
Pemotong
切割机

Grinding / Sanding
Pengisar / Pasir
磨削 / 打磨

Sawing
Gergaji
电锯

Planing / Routing
Pengisar / Tangkai
刨削 / 榫槽

Others
Lain-lain
其他

Outdoor Power Equipment
Alatan Kerja Luar
园具-户外

Makita
Makita

BRUSHLESS MOTOR

Motor tanpa berus 无碳刷马达

- Maintenance-free due to no brush
- Life time work amount of a battery is increased
- Durable against long continuous operation
- More work amount on a single full battery charge

penyenggaraan mudah tanpa proses penggantian berus karbon. Alat yang menggunakan motor berus BL tidak mengalami geseran haba, dengan itu menjadikan bateri lebih tahan lama. 免却更换碳刷的前项工序，保养较简单。采用BL无碳刷马达的工具没有因摩擦热导致的能量流失，所以每次充电后的连续工作时间更长。



BL MOTOR
Motor tanpa berus
无碳刷马达

BRUSHED MOTOR

Motor dengan berus 有刷马达

- High power-to-weight ratio obtained by employing 4-pole motor
- Berkuasa tinggi dengan motor 4-pole
采用4极马达，高功率



4-POLE MOTOR

2-POLE MOTOR

Max Fastening Torque

Maksimum Tenaga Pemutaran Pengancing
最大紧固扭力

Soft Joint

65 N-m

60 N-m

50

40

30 N-m

27 N-m

25 N-m

25 N-m

23 N-m

20

10

Max Fastening Torque

Maksimum Tenaga Pemutaran Pengancing
最大紧固扭力

Hard Joint

130 N-m

130

115 N-m

100

91 N-m

90

80

70

62 N-m

60

54 N-m

50 N-m

45 N-m

40 N-m

40 N-m

30

20

10

Max Fastening Torque

Maksimum Tenaga Pemutaran Pengancing
最大紧固扭力

Soft Joint

60

58 N-m

50

40

36 N-m

30

27 N-m

20

10

DHP486

Cordless Hammer Driver Drill
Tukul Pemutar Skru Bergerudi tanpa Kord
充电式冲击螺丝起子电钻

DDF486

Cordless Driver Drill
Gerudi Pemutar Skru tanpa Kord 充电式螺丝起子电钻

BL MOTOR XPT

DHP481

Cordless Hammer Driver Drill
Tukul Pemutar Skru Bergerudi tanpa Kord
充电式冲击螺丝起子电钻

DDF481

Cordless Driver Drill
Gerudi Pemutar Skru tanpa Kord 充电式螺丝起子电钻

BL MOTOR XPT

DHP484

Cordless Hammer Driver Drill
Tukul Pemutar Skru Bergerudi tanpa Kord
充电式冲击螺丝起子电钻

DDF484

Cordless Driver Drill
Gerudi Pemutar Skru tanpa Kord 充电式螺丝起子电钻

BL MOTOR XPT

DHP485

Cordless Hammer Driver Drill
Tukul Pemutar Skru Bergerudi tanpa Kord
充电式冲击螺丝起子电钻

DDF485

Cordless Driver Drill
Gerudi Pemutar Skru tanpa Kord 充电式螺丝起子电钻

BL MOTOR XPT

DHP459

Cordless Hammer Driver Drill
Tukul Pemutar Skru Bergerudi tanpa Kord
充电式冲击螺丝起子电钻

DDF459

Cordless Driver Drill
Gerudi Pemutar Skru tanpa Kord 充电式螺丝起子电钻

BL MOTOR XPT

DHP487

Cordless Hammer Driver Drill
Tukul Pemutar Skru Bergerudi tanpa Kord
充电式冲击螺丝起子电钻

DDF487

Cordless Driver Drill
Gerudi Pemutar Skru tanpa Kord 充电式螺丝起子电钻

BL MOTOR XPT

DHP483

Cordless Hammer Driver Drill
Tukul Pemutar Skru Bergerudi tanpa Kord
充电式冲击螺丝起子电钻

DDF483 | DDF083

Cordless Driver Drill
Gerudi Pemutar Skru tanpa Kord 充电式螺丝起子电钻

BL MOTOR XPT



DHP458

Cordless Hammer Driver Drill
Tukul Pemutar Skru Bergerudi tanpa Kord
充电式冲击螺丝起子电钻

DDF458

Cordless Driver Drill
Gerudi Pemutar Skru tanpa Kord 充电式螺丝起子电钻

XPT

DHP482

Cordless Hammer Driver Drill
Tukul Pemutar Skru Bergerudi tanpa Kord
充电式冲击螺丝起子电钻

DDF482

Cordless Driver Drill
Gerudi Pemutar Skru tanpa Kord 充电式螺丝起子电钻

XPT

DHP453

Cordless Hammer Driver Drill
Tukul Pemutar Skru Bergerudi tanpa Kord
充电式冲击螺丝起子电钻

DDF453

Cordless Driver Drill
Gerudi Pemutar Skru tanpa Kord 充电式螺丝起子电钻

2-POLE MOTOR

* All list price shown are for reference only (exclude SST).

* Semua harga yang ditunjukkan adalah untuk rujukan sahaja (tidak termasuk SST). 所有显示的建议零售价仅供参考 (不包括SST)。

18V

LXT

Li-ion Ah 6.0 5.0 4.0 3.0 2.0 1.5

DHP486RTE | DHP486Z 13mm (1/2")

Cordless Hammer Driver Drill

Tukul Pemutar Skru Bergerudi Tanpa Kord
充电式冲击螺丝起子电钻

- Increased performance in continuous heavy-duty applications



Standard Equipment: Depth Gauge, Side Handle, Belt Clip, (+)(-) Bit, Bit Holder

- RTE: 1x Rapid Charger, 2x 5.0Ah Battery
- Z: Without Charger, Battery & Carrying Case



Capacity Kapasiti 能力	Siding Board: 170mm (6-11/16") Wood (Auger-Bit): 50mm (2") Wood (Hole Saw): 152mm (6")
Impacts Per Minute (IPM) Impak Per Minit 冲击数	High: 0 - 31,500 Low: 0 - 8,250
No Load Speed (RPM) Kelajuan Tanpa Beban 回转数	High: 0 - 2,100 Low: 0 - 550
Max Fastening Torque Maksimum Tenaga Pemutaran Pengancing 最大紧固扭力	Hard: 130N·m (1,150in.lbs.) Soft: 65N·m (580in.lbs.)
Max Lock Torque Pemutaran Tenaga Maksimum 最大锁紧扭力	125N·m (1,100in.lbs.)
Dimensions (L x W x H) Dimensi 体积	178x81x265mm (7x3-3/16x10-3/8")
Net Weight Berat Bersih 净重	2.3 - 2.7kg (5.1 - 6.0lbs.)
Work Amount (approx.) Jumlah Kerja 工作量	710 holes with BL1850B Wood bit ø21mm (30mm thick melapi) High Speed

DHP481RTE | DHP481RFE | DHP481Z 13mm (1/2")

Cordless Hammer Driver Drill

Tukul Pemutar Skru Bergerudi Tanpa Kord
充电式冲击螺丝起子电钻

- 0-31,500 IPM for fast hammer drilling in masonry materials



Standard Equipment: Depth Gauge, Side Grip, Belt Clip, (+)(-) Bit, Bit Holder

- RTE: 1x Rapid Charger, 2x 5.0Ah Battery
- RFE: 1x Rapid Charger, 2x 3.0Ah Battery
- Z: Without Charger, Battery & Carrying Case



Capacity Kapasiti 能力	Steel: 13mm (1/2") Wood: 76mm (3") Masonry: 16mm (5/8")
Chuck Capacity Kapasiti Chuck 夹头能力	1.5 - 13mm (1/16 - 1/2")
Impacts Per Minute (IPM) Impak Per Minit 冲击数	High: 0 - 31,500 Low: 0 - 8,250
No Load Speed (RPM) Kelajuan Tanpa Beban 回转数	High: 0 - 2,100 Low: 0 - 550
Max Fastening Torque Maksimum Tenaga Pemutaran Pengancing 最大紧固扭力	Hard: 115N·m (1,020in.lbs.) Soft: 60N·m (530in.lbs.)
Max Lock Torque Pemutaran Tenaga Maksimum 最大锁紧扭力	125N·m (1,090in.lbs.)
Dimensions (L x W x H) Dimensi 体积	205x79x249mm (8-1/8"x3-1/8"x9-3/4")
Net Weight Berat Bersih 净重	2.7 - 3.0kg (6.0 - 6.7lbs)
Work Amount (approx.) Jumlah Kerja 工作量	630 pcs with BL1850B Wood Screw ø21 x 25mm

DHP458RME | DHP458RFE | DHP458Z 13mm (1/2")

Cordless Hammer Driver Drill

Tukul Pemutar Skru Bergerudi Tanpa Kord
充电式冲击螺丝起子电钻

- All metal gears and aluminum gear housing for maximum jobsite durability



Standard Equipment: (+)(-) Bit, Side Grip, Depth Rod, Bit Holder

- RME: 1x Rapid Charger, 2x 4.0Ah Battery
- RFE: 1x Rapid Charger, 2x 3.0Ah Battery
- Z: Without Charger, Battery & Carrying Case



Capacity Kapasiti 能力	Steel: 13mm (1/2") Wood: 76mm (3") Masonry: 16mm (5/8")
No Load Speed (RPM) Kelajuan Tanpa Beban 回转数	High: 0-2,000 Low: 0-400
Impacts Per Minute (IPM) Impak Per Minit 冲击数	High: 0-30,000 Low: 0-6,000
Max Fastening Torque Maksimum Tenaga Pemutaran Pengancing 最大紧固扭力	Hard: 91N·m Soft: 58N·m
Max Lock Torque Pemutaran Tenaga Maksimum 最大锁紧扭力	84N·m (750in.lbs.)
Dimensions (L x W x H) Dimensi 体积	225x79x259mm (8-7/8"x3-1/8"x10-1/4")
Net Weight Berat Bersih 净重	2.2 - 2.6kg (4.9 - 5.7lbs)
Work Amount (approx.) Jumlah Kerja 工作量	500 pcs with BL1850B Wood Screw ø9 x 25mm

DHP482RME | DHP482RFE | DHP482Z 13mm (1/2")

Cordless Hammer Driver Drill

Tukul Pemutar Skru Bergerudi Tanpa Kord
充电式冲击螺丝起子电钻

- High speed model with compact and lightweight design



Standard Equipment: Belt Clip, (+)(-) Bit

- RME: 1x Rapid Charger, 2x 4.0Ah Battery
- RFE: 1x Rapid Charger, 2x 3.0Ah Battery
- Z: Without Charger, Battery & Carrying Case



Capacity Kapasiti 能力	Steel: 13mm (1/2") Wood: 38mm (1-1/2") Masonry: 13mm (1/2")
Chuck Capacity Kapasiti Chuck 夹头能力	1.5 - 13mm (1/16 - 1/2")
Impacts Per Minute (IPM) Impak Per Minit 冲击数	High: 0 - 28,500 Low: 0 - 9,000
No Load Speed (RPM) Kelajuan Tanpa Beban 回转数	High: 0 - 1,900 Low: 0 - 600
Max Fastening Torque Maksimum Tenaga Pemutaran Pengancing 最大紧固扭力	Hard: 62N·m (550 in.lbs.) Soft: 36N·m (320 in.lbs.)
Max Lock Torque Pemutaran Tenaga Maksimum 最大锁紧扭力	54N·m (480in.lbs.)
Dimensions (L x W x H) Dimensi 体积	198x79x249mm (7-3/4"x3-1/8"x9-3/4")
Net Weight Berat Bersih 净重	1.5 - 1.8kg (3.4 - 4.1lbs)
Work Amount (approx.) Jumlah Kerja 工作量	781 holes with BL1850B Brad Point Wood Bit ø8mm (1" Depth Mixed wood)

DHP484RME | DHP484RFE | DHP484Z 13mm (1/2")

Cordless Hammer Driver Drill

Tukul Pemutar Skru Bergerudi Tanpa Kord
充电式冲击螺丝起子电钻

- 0-30,000 IPM for fast hammer drilling in masonry materials



Standard Equipment: Belt Clip, (+)(-) Bit

- RME: 1x Rapid Charger, 2x 4.0Ah Battery
- RFE: 1x Rapid Charger, 2x 3.0Ah Battery
- Z: Without Charger, Battery & Carrying Case



Capacity Kapasiti 能力	Steel: 13mm (1/2") Wood: 38mm (1-1/2") Masonry: 13mm (1/2")
Chuck Capacity Kapasiti Chuck 夹头能力	1.5 - 13mm (1/16 - 1/2")
Impacts Per Minute (IPM) Impak Per Minit 冲击数	High: 0 - 30,000 Low: 0 - 7,500
No Load Speed (RPM) Kelajuan Tanpa Beban 回转数	High: 0 - 2,000 Low: 0 - 500
Max Fastening Torque Maksimum Tenaga Pemutaran Pengancing 最大紧固扭力	Hard: 54 N·m (480 in.lbs.) Soft: 30 N·m (270 in.lbs.)
Max Lock Torque Pemutaran Tenaga Maksimum 最大锁紧扭力	60N·m (530in.lbs.)
Dimensions (L x W x H) Dimensi 体积	182x79x261mm (7-1/8"x3-1/8"x10-1/4")
Net Weight Berat Bersih 净重	1.6 - 1.9kg (3.5 - 4.2lbs)
Work Amount (approx.) Jumlah Kerja 工作量	1850 pcs with BL1850B Wood Screw ø9 x 25mm

* All list price shown are for reference only (exclude SST).

* Semua harga yang ditunjukkan adalah untuk rujukan sahaja (tidak termasuk SST). 所有显示的建议零售价仅供参考 (不包括SST)。

Cordless
Target Applications

LED Flashlight
Lampu Saku LED
LED手电筒

Vacuum Cleaner
Pembersih Vakuum
吸尘器

Drilling / Fastening
Ganuli / Pemasang
钻孔 / 紧固

Impact Drilling / Demolition
Ganuli / Pemasang
石工钻孔 / 拆墙施工

Cutting
Pemotong
切割

Grinding / Sanding
Pengkilan / Poles
打磨 / 砂磨

Sawing
Gergaji
锯切

Planing / Routing
Pengkilan / Tangkapan
刨削 / 雕刻

Others
Lain-lain
其他

Outdoor Power Equipment
Alatan Kerja Luar
园机/户外

Thakita
TENT



Li-ion Ah 6.0 | 5.0 | 4.0 | 3.0 | 2.0 | 1.5



Cordless
Tanpa Kord / 无线式

LED Flashlight
Lampu Suluhi LED
LED 照明灯

Vacuum Cleaner
Penyedut Vakuum
吸尘器

Drilling / Fastening
Ganjal / Pengikat
钻孔 / 紧固

Impact Drilling / Demolition
Ganjal / Perusak
起工钻孔 / 拆墙加工

Grinding / Sanding
Pangras / Pasukan
磨削 / 打磨

Sawing
Gergaji
电锯

Planing / Routing
Pangras / Tangkapan
刨削 / 雕刻

Others
Lain-lain
其他

Outdoor Power Equipment
Alatan Kerja Luar
园具-户外



DHP485RFE | DHP485Z 13mm (1/2")

Cordless Hammer Driver Drill
Tukul Pemutar Skru Bergerudi
Tanpa Kord
充电式冲击螺丝起子电钻



- All metal gear construction provides increased durability

Standard Equipment: Belt Clip, (+)(-) Bit

- RFE: 1x Rapid Charger, 2x 3.0Ah Battery
- Z: Without Charger, Battery & Carrying Case



Capacity Kapasiti 能力	Steel: 13 (1/2") Wood: 38 (1-1/2") Masonry: 13mm (1/2")
Chuck Capacity Kapasiti Chuck 夹头能力	1.5 - 13mm (1/16 - 1/2")
Impacts Per Minute (IPM) Impak Per Minit 冲击数	High: 0 - 28,500 Low: 0 - 7,500
No Load Speed (RPM) Kelajuan Tanpa Beban 回转数	High: 0 - 1900 Low: 0 - 500
Max Fastening Torque Maksimum Tenaga Pemutaran Pengancing 最大紧固扭力	Hard: 50N-m (440in.lbs.) Soft: 27N-m (240in.lbs.)
Max Lock Torque Pemutaran Tenaga Maksimum 最大锁紧扭力	50N-m (440in.lbs.)
Dimensions (L x W x H) Dimensi 体积	182x79x255mm (7-1/8"x3-1/8"x10")
Net Weight Berat Bersih 净重	1.5 - 1.8kg (3.2 - 3.9lbs.)
Work Amount (approx.) Jumlah Kerja 工作量	1400 pcs with BL1850B Auger Bit ø15mm (30mm thick Melapi)

DHP459Z 13mm (1/2")

Cordless Hammer Driver Drill
Tukul Pemutar Skru Bergerudi
Tanpa Kord
充电式冲击螺丝起子电钻



- Brushless motor delivers up to 50% longer run time per charge

Standard Equipment: Belt Clip, (+)(-) Bit

- Z: Without Charger & Battery



Semua stok mungkin akan habis
WHILE STOCK LAST

Capacity Kapasiti 能力	Steel: 13mm (1/2") Wood: 38mm (1-1/2") Masonry: 13mm (1/2")
Chuck Capacity Kapasiti Chuck 夹头能力	1.5 - 13mm (1/16 - 1/2")
Impacts Per Minute (IPM) Impak Per Minit 冲击数	High: 0 - 22,500 Low: 0 - 6,000
No Load Speed (RPM) Kelajuan Tanpa Beban 回转数	High: 0 - 1,500 Low: 0 - 400
Max Fastening Torque Maksimum Tenaga Pemutaran Pengancing 最大紧固扭力	Hard: 45N-m (400in.lbs.) Soft: 25N-m (220in.lbs.)
Max Lock Torque Pemutaran Tenaga Maksimum 最大锁紧扭力	45N-m (400in.lbs.)
Dimensions (L x W x H) Dimensi 体积	192x78x256mm (7-9/16"x3-1/16"x10-1/8")
Net Weight Berat Bersih 净重	1.5 - 1.8kg (3.3 - 4.0lbs)
Work Amount (approx.) Jumlah Kerja 工作量	1470pcs with BL1850B Auger Bit ø15mm (30mm thick Melapi)

DHP453RME | DHP453RFE | DHP453SYE | DHP453Z 13mm (1/2")

Cordless Hammer Driver Drill
Tukul Pemutar Skru Bergerudi
Tanpa Kord
充电式冲击螺丝起子电钻



- 16 Adjustable torque settings plus drill mode

Standard Equipment: (+)(-) Bit

- RME: 1x Rapid Charger, 2x 4.0Ah Battery
- RFE: 1x Rapid Charger, 2x 3.0Ah Battery
- SYE: 1x Standard Charger, 2x 1.5Ah Battery
- Z: Without Charger, Battery & Carrying Case

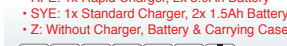

Capacity Kapasiti 能力	Steel: 13mm (1/2") Wood: 36mm (1-7/16") Masonry: 13mm (1/2")
Impacts Per Minute (IPM) Impak Per Minit 冲击数	High: 0 - 19,500 Low: 0 - 6,000
No Load Speed (RPM) Kelajuan Tanpa Beban 回转数	High: 0 - 1,300 Low: 0 - 400
Max Fastening Torque Maksimum Tenaga Pemutaran Pengancing 最大紧固扭力	Hard: 42N-m Soft: 27N-m
Max Lock Torque Pemutaran Tenaga Maksimum 最大锁紧扭力	38N-m (340in.lbs.)
Dimensions (L x W x H) Dimensi 体积	240x79x244mm (9-7/16"x3-1/8"x9-5/8")
Net Weight Berat Bersih 净重	1.7 - 2.0kg (3.6 - 4.4lbs)
Work Amount (approx.) Jumlah Kerja 工作量	720pcs with BL1850B Wood Screw ø4.1 x 38mm

Model No. 型号	Capacity Kapasiti 能力			No Load Speed (rpm) Kelajuan Tanpa Beban 回转数	Impacts Per Minute (IPM) Impak Per Minit 冲击数	Torque Setting Tetapan Pemutaran 扭转设置	Max. Fastening Torque Maksimum Tenaga Pemutaran Pengancing 最大紧固扭力	Overall Length (mm) Panjang Keseluruhan 总长度	Net Weight Berat Bersih 净重	BL MOTOR	XPT
	Steel	Wood	Masonry								
DHP486	13mm	76mm	16mm	0-2,100 / 0-550	High: 0 - 31,500 / Low: 0 - 8,250	21	Hard: 130 / Soft: 65	178	2.3kg (5.1lbs)	●	●
DHP481	13mm	76mm	16mm	0-2,100 / 0-550	High: 0 - 31,500 / Low: 0 - 8,250	21	Hard: 115 / Soft: 60	205	2.7kg (6.0lbs)	●	●
DHP458	13mm	76mm	16mm	0-2,000 / 0-400	High: 0 - 30,000 / Low: 0 - 6,000	21	Hard: 91 / Soft: 58	225	2.2kg (4.9lbs)	●	●
DHP482	13mm	38mm	13mm	0 - 1,900 / 0 - 600	High: 0 - 28,500 / Low: 0 - 9,000	21	Hard: 62 / Soft: 36	198	1.5kg (3.4lbs)	●	●
DHP484	13mm	38mm	13mm	0-2,000 / 0-500	High: 0 - 30,000 / Low: 0 - 7,500	21	Hard: 54 / Soft: 30	182	1.6kg (3.5lbs)	●	●
DHP485	13mm	38mm	13mm	0-1,900 / 0-500	High: 0 - 28,500 / Low: 0 - 7,500	21	Hard: 50 / Soft: 27	182	1.5kg (3.2lbs)	●	●
DHP459	13mm	38mm	13mm	0-1,500 / 0-400	High: 0 - 22,500 / Low: 0 - 6,000	16	Hard: 45 / Soft: 25	192	1.5kg (3.3lbs)	●	●
DHP453	13mm	36mm	13mm	0-1,300 / 0-400	High: 0 - 19,500 / Low: 0 - 6,000	16	Hard: 42 / Soft: 27	240	1.7kg (3.6lbs)	●	●
DHP487	13mm	36mm	13mm	0-1,700 / 0-500	High: 0 - 25,500 / Low: 0 - 7,500	20	Hard: 40 / Soft: 25	164	1.4kg (3.1lbs)	●	●
DHP483	13mm	36mm	13mm	0-1,700 / 0-500	High: 0 - 25,500 / Low: 0 - 7,500	20	Hard: 40 / Soft: 23	176	1.3kg (2.8lbs)	●	●

* All list price shown are for reference only (exclude SST).

* Semua harga yang ditunjukkan adalah untuk rujukan sahaja (tidak termasuk SST). 所有显示的建议零售价仅供参考 (不包括SST)。

18V

LXT

Li-ion Ah 6.0 5.0 4.0 3.0 2.0 1.5

DHP487 Cordless Hammer Driver Drill

BL
MOTOR

XPT

Max Lock
Torque
40N·m

Light Weight
1.4kg



Compact



Twin LED job light with
preglow and afterglow
functions



Variable speed
control trigger



Mechanical 2-speed
gearing

DHP487RAJ | DHP487Z 13mm (1/2")

Cordless Hammer Driver Drill

Tukul Pemutar Skru Bergerudi
Tanpa Kord
充电式冲击螺丝起子电钻

- Compact design at only 164mm long for increased operability

Standard Equipment: Belt Clip, (+/-) Bit

- RAJ: 1x Rapid Charger, 2x 2.0Ah Battery, 1x Makpac Connector Box
- Z: Without Charger, Battery & Carrying Case



*Not applicable
for Z model

BL MOTOR XPT



Capacity Kapasiti 能力	Steel: 13mm (1/2") Masonry: 13mm (1/2") Wood (Self-Feed Bit): 35 mm (1-3/8") Wood (Auger Bit): 36 mm (1-7/16") Wood (Hole Saw): 51 mm (2") 1.5 - 13 mm (1/16 - 1/2")
Chuck Capacity Kapasiti Chuck 夹头能力	1.5 - 13mm (1/16 - 1/2")
Impacts Per Minute (IPM) Impak Per Minit 冲击数	High: 0 - 25,500 Low: 0 - 7,500
No Load Speed (RPM) Kelajuan Tanpa Beban 回转数	High: 0 - 1,700 Low: 0 - 500
Max Fastening Torque Maksimum Tenaga Pemutaran Pengancing 最大紧固扭力	Hard: 40N·m (350 in.lbs.) Soft: 25N·m (220 in.lbs.)
Max Lock Torque Pemutaran Tenaga Maksimum 最大锁紧扭力	40N·m (350in.lbs.)
Dimensions (L x W x H) Dimensi 体积	164x81x248mm (6-1/2x3-3/16x9-3/4")
Net Weight Berat Bersih 净重	1.4 - 1.7kg (3.1 - 3.7lbs.)
Work Amount (approx.) Jumlah Kerja 工作量	640 holes with BL1820B Wood bit ø9mm (30mm thick melapi) High Speed

DHP483RME | DHP483RFE | DHP483Z 13mm (1/2")

Cordless Hammer Driver Drill

Tukul Pemutar Skru Bergerudi
Tanpa Kord
充电式冲击螺丝起子电钻

- 0-25,500 IPM for fast hammer drilling in masonry materials

Standard Equipment: Belt Clip, (+/-) Bit

- RME: 1x Rapid Charger, 2x 4.0Ah Battery
- RFE: 1x Rapid Charger, 2x 3.0Ah Battery
- Z: Without Charger, Battery & Carrying Case



*Not applicable
for Z model

BL MOTOR XPT



Capacity Kapasiti 能力	Steel: 13mm (1/2") Wood: 36mm (1-7/16") Masonry: 13mm (1/2")
Chuck Capacity Kapasiti Chuck 夹头能力	1.5 - 13mm (1/16 - 1/2")
Impacts Per Minute (IPM) Impak Per Minit 冲击数	High: 0 - 25,500 Low: 0 - 7,500
No Load Speed (RPM) Kelajuan Tanpa Beban 回转数	High: 0 - 1,700 Low: 0 - 500
Max Fastening Torque Maksimum Tenaga Pemutaran Pengancing 最大紧固扭力	Hard: 40N·m (350 in.lbs.) Soft: 23N·m (210 in.lbs.)
Max Lock Torque Pemutaran Tenaga Maksimum 最大锁紧扭力	40N·m (350in.lbs.)
Dimensions (L x W x H) Dimensi 体积	176x79x247mm (6-15/16"x3-1/8"x9-3/4")
Net Weight Berat Bersih 净重	1.3 - 1.6kg (2.8 - 3.6lbs)
Work Amount (approx.) Jumlah Kerja 工作量	200pcs with BL1850B Wood screw ø6 x 75mm

* All list price shown are for reference only (exclude SST).

* Semua harga yang ditunjukkan adalah untuk rujukan sahaja (tidak termasuk SST). 所有显示的建议零售价仅供参考 (不包括SST)。

Cordless
Tanpa Kord 充电式

LED Flashlight
Lampu Suhu LED
LED 闪光灯

Vacuum Cleaner
Pembersih Vakuum
吸尘器

Drilling / Fastening
Ganuli / Pemasah
钻孔 / 紧固

Impact Drilling / Demolition
Ganuli / Pemasah
冲击钻孔 / 拆毁施工

Cutting
Pemotong
切割

Grinding / Sanding
Pengkilan / Pemoles
打磨 / 砂磨

Sawing
Gergaji
锯切

Planing / Routing
Pengaliran / Tumpang
刨削 / 压花

Others
Lain-lain
其他

Outdoor Power Equipment
Alatan Kuat Luar
户外动力工具

Makita
MAKITA

Cordless
Target Kord 无绳式

LED Flashlight
Lampu Suluhan LED
LED 照明灯

Vacuum Cleaner
Pembersih Vakuum
吸尘器

Drilling / Fastening
Draib / Pengikat
钻孔 / 紧固

Impact Drilling / Demolition
Draib / Perseksi
起工钻孔 / 拆墙加工

Cutting
Pemotong
切割

Grinding / Sanding
Pengisar / Pasir
打磨 / 砂磨

Sawing
Gergaji
电锯

Planing / Routing
Pengisar / Tangkai
刨削 / 榫槽

Others
Lain-lain
其他

Outdoor Power Equipment
Alat-alat Keras Luar
园林-户外

Makita
MAKITA

BRUSHLESS MOTOR

Motor tanpa berus 无碳刷马达

- Maintenance-free due to no brush
 - Life time work amount of a battery is increased
 - Durable against long continuous operation
 - More work amount on a single full battery charge
- penyenggaraan mudah tanpa proses penggantian berus karbon
Alat yang menggunakan motor berus BL tidak mengalami geseran haba, dengan itu menjadikan bateri lebih tahan lama
免却更换碳刷的麻烦工序，保养较简单
采用BL无碳刷马达的工具没有因摩擦热导致的能量流失，所以每次充电后的连续工作时间更长



BRUSHED MOTOR

Motor dengan berus 有刷马达

- High power-to-weight ratio obtained by employing 4-pole motor
- Berkuasa tinggi dengan motor 4-pole
采用4极马达，高功率



Max Fastening Torque

Maksimum Tenaga Pemutaran Pengancing 最大紧固扭力

180 N·m

175 N·m

170 N·m

165 N·m

155 N·m

140 N·m

A mode [assist mode]

helps to eliminate "screw cam-out" and "cross threading" by driving at low speed until the start of tightening.

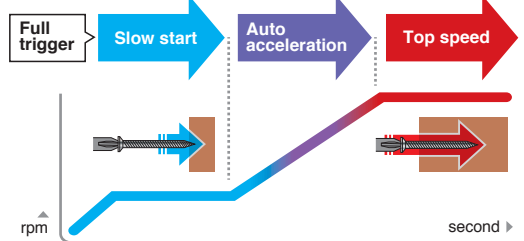

DTD172 | DTD171
Cordless Impact Driver
Pemutar Skru Impak tanpa Kord 充电式冲击螺丝起子机

BL MOTOR XPT

4 STAGE power selection + TEKS MODE

Icon: A mode

DTD170
Cordless Impact Driver
Pemutar Skru Impak tanpa Kord 充电式冲击螺丝起子机

BL MOTOR XPT

4 STAGE power selection + TEKS MODE + A mode icon

DTD154
Cordless Impact Driver
Pemutar Skru Impak tanpa Kord 充电式冲击螺丝起子机

BL MOTOR XPT

3 STAGE power selection + TEKS MODE

DTD153
Cordless Impact Driver
Pemutar Skru Impak tanpa Kord 充电式冲击螺丝起子机

BL MOTOR XPT

Ideal for applications such as tightening of self-drilling screws

DTD157 | DTD155
Cordless Impact Driver
Pemutar Skru Impak tanpa Kord 充电式冲击螺丝起子机

BL MOTOR XPT

2 STAGE power selection + A mode icon

DTD149
Cordless Impact Driver
Pemutar Skru Impak tanpa Kord 充电式冲击螺丝起子机

XPT 4-POLE MOTOR

DTD152
Cordless Impact Driver
Pemutar Skru Impak tanpa Kord 充电式冲击螺丝起子机

XPT 4-POLE MOTOR

Ideal for applications such as tightening of self-drilling screws

DTD156
Cordless Impact Driver
Pemutar Skru Impak tanpa Kord 充电式冲击螺丝起子机

4-POLE MOTOR

DTS141
Cordless Oil-Pulse Driver
Pemutar Skru Impak tanpa Kord 充电式冲击起子机

BL MOTOR XPT

3 STAGE power selection + TEKS MODE

SOFT IMPACT

Low Noise 77dB

Suitable for noise sensitive job site

40 N·m

DTP141
Cordless 4 Mode Impact Driver
Pemutar Skru Impak tanpa Kord 充电式冲击螺丝起子机

BL MOTOR

3 STAGE power selection + TEKS MODE

4 Operation modes: Impact driver / Hammer drill / Drill / Screwdriver

150 N·m

"Tek's" mode is a special mode optimum for fast tightening of self drilling screws without damaging the screw and the workpiece.

"Tek's" mod adalah mod khas yang optimum untuk mengikat skru penggerudian sendiri tanpa cepat merosakkan skru dan bahan kerja.

"Tek's" 模式是一种特殊模式，可以在不损坏螺钉和工件的情况下快速拧紧自攻螺钉。

Tek's mode

* All list price shown are for reference only (exclude SST).

* Semua harga yang ditunjukkan adalah untuk rujukan sahaja (tidak termasuk SST). 所有显示的建议零售价仅供参考 (不包括SST)。

18V

LXT

Li-ion Ah 6.0 5.0 4.0 3.0 2.0 1.5

DTD172RTJ | DTD172Z

Cordless Impact Driver
Pemutar Skru Impak Tanpa Kord
充电式冲击螺丝起子机



- Anti-bit wobbling structure; Two ball bearings are used to securely hold the anvil for reduced bit wobbling

Standard Equipment: Belt Clip

- RTJ: 1x Rapid Charger, 2x 5.0Ah Battery, 1x Makpac Connector Box
- Z: Without Charger, Battery & Carrying Case



*Not applicable for Z model



NEW BARU 新



Capacity Kapasiti 能力	Machine Screw: M4 - M8 (5/32" - 5/16") Standard Bolt: M5 - M16 (3/16" - 5/8") High Strength Bolt: M5 - M14 (3/16" - 9/16") Coarse thread (in length): 22 - 125mm (7/8" - 4-7/8") Wood (Auger Bit): 24 mm (15/16")
Hex Shank Batang Heksagon 六角柄	6.35mm (1/4")
No Load Speed (RPM) Kelajuan Tanpa Beban 回转数	Max / Hard / Mid / Soft / Wood / Bolt / T (1) / T (2) mode: 0 - 3,600 / 3,200 / 2,100 / 1,100 / 1,800 / 3,600 / 2,900 / 3,600
Impacts Per Minute (IPM) Impak Per Minit 冲击数	Max / Hard / Mid / Soft / Wood / Bolt / T (1) / T (2) mode: 0 - 3,800 / 3,600 / 2,600 / 1,100 / 3,800 / 3,800 / N/A / 2,600
Max Fastening Torque Tenaga Pemutaran Pengancing Maksimum 最大紧固扭力	180N-m (1,590in.lbs.)
Dimensions (L x W x H) Dimensi 体积	114x81x236mm (4-1/2x3-3/16x9-1/4")
Net Weight Berat Bersih 净重	1.2 - 1.5kg (2.6 - 3.3lbs.)
Work Amount (approx.) Jumlah Kerja 工作量	970 pcs with BL1860B Coarse thread screw 65mm

DTD171RTJ | DTD171RFJ | DTD171Z

Cordless Impact Driver
Pemutar Skru Impak Tanpa Kord
充电式冲击螺丝起子机



- Ultra Compact and perfect balance at only 116mm long

Standard Equipment: Belt Clip

- RTJ: 1x Rapid Charger, 2x 5.0Ah Battery, 1x Makpac Connector Box
- RFJ: 1x Rapid Charger, 2x 3.0Ah Battery, 1x Makpac Connector Box
- Z: Without Charger, Battery & Carrying Case



*Not applicable for Z model



Capacity Kapasiti 能力	Machine Screw: M4 - M8 (5/32" - 5/16") Standard Bolt: M5 - M16 (3/16" - 5/8") High Tensile Bolt: M5 - M14 (3/16" - 9/16") Coarse thread (in length): 22 - 125mm (7/8" - 4-7/8")
Hex Shank Batang Heksagon 六角柄	6.35mm (1/4")
No Load Speed (RPM) Kelajuan Tanpa Beban 回转数	Max/ Hard/ Med/ Soft/ Wood/ Bolt/ T(1)/ T(2) mode: 0 - 3,600/ 3,200/ 2,100/ 1,100/ 1,800/ 3,600/ 2,900/ 3,600
Impacts Per Minute (IPM) Impak Per Minit 冲击数	Max/ Hard/ Med/ Soft/ Wood/ Bolt/ T(1)/ T(2) mode: 0 - 3,800/ 3,600/ 2,600/ 1,100/ 3,800/ 3,800/ N/A/ 2,600
Max Fastening Torque Maksimum Tenaga Pemutaran Pengancing 最大紧固扭力	180N-m (1,590in.lbs.)
Fastening Torque Tenaga Pemutaran Pengancing 扭力	Hard: 170N-m (1,510in.lbs.) Med: 50N-m (440in.lbs.) Soft: 20 N-m (180 in.lbs.)
Dimensions (L x W x H) Dimensi 体积	116x79x236mm (4-9/16"x3-1/8"x9-1/4")
Net Weight Berat Bersih 净重	1.2 - 1.6kg (2.7 - 3.4lbs.)
Work Amount (approx.) Jumlah Kerja 工作量	808 pcs with BL1850B Coarse thread screw 65mm

DTD170RME | DTD170RFE | DTD170Z

Cordless Impact Driver
Pemutar Skru Impak Tanpa Kord
充电式冲击螺丝起子机



- 6-Mode operation for A-mode/ T-mode/ Max/ Hard/ Medium/ Soft impact mode for multiple applications

Standard Equipment: Belt Clip

- RME: 1x Rapid Charger, 2x 4.0Ah Battery
- RFE: 1x Rapid Charger, 2x 3.0Ah Battery
- Z: Without Charger, Battery & Carrying Case



*Not applicable for Z model



Capacity Kapasiti 能力	Machine Screw: M4 - M8 (5/32" - 5/16") Standard Bolt: M5 - M16 (3/16" - 5/8") High Tensile Bolt: M5 - M14 (3/16" - 9/16") Coarse Thread (in length): 22 - 125mm (7/8" - 4-7/8")
Hex Shank Batang Heksagon 六角柄	6.35mm (1/4")
No Load Speed (RPM) Kelajuan Tanpa Beban 回转数	Max: 0 - 3,600 Hard: 3,200 Med: 2,100 Soft: 1,100 T Mode: 3,600
Impacts Per Minute (IPM) Impak Per Minit 冲击数	Max: 0 - 3,800 Hard: 3,600 Med: 2,600 Soft: 1,100 T mode: 2,600
Max Fastening Torque Maksimum Tenaga Pemutaran Pengancing 最大紧固扭力	175N-m (1,550in.lbs.)
Dimensions (L x W x H) Dimensi 体积	117x79x236mm (4-5/8"x3-1/8"x9-1/4")
Net Weight Berat Bersih 净重	1.2 - 1.5kg (2.7 - 3.4lbs)
Work Amount (approx.) Jumlah Kerja 工作量	808 pcs with BL1850B Coarse thread screw 65mm

DTD154RME | DTD154RFE | DTD154Z

Cordless Impact Driver
Pemutar Skru Impak Tanpa Kord
充电式冲击螺丝起子机



- Aluminum hammer case creates the impression of rigidity of the machine

Standard Equipment: Belt Clip

- RME: 1x Rapid Charger, 2x 4.0Ah Battery
- RFE: 1x Rapid Charger, 2x 3.0Ah Battery
- Z: Without Charger, Battery & Carrying Case



*Not applicable for Z model



Capacity Kapasiti 能力	Machine Screw: M4 - M8 (5/32" - 5/16") Standard Bolt: M5 - M16 (3/16" - 5/8") High Tensile Bolt: M5 - M14 (3/16" - 9/16") Coarse Thread (in length): 22 - 125mm (7/8" - 4-7/8")
Hex Shank Batang Heksagon 六角柄	6.35mm (1/4")
No Load Speed (RPM) Kelajuan Tanpa Beban 回转数	0 - 3,600 0 - 2,100 0 - 1,100
Impacts Per Minute (IPM) Impak Per Minit 冲击数	0 - 3,800 0 - 2,600 0 - 1,100
Max Fastening Torque Maksimum Tenaga Pemutaran Pengancing 最大紧固扭力	175N-m (1,550in.lbs.)
Dimensions (L x W x H) Dimensi 体积	117x79x236mm (4-5/8"x3-1/8"x9-1/4")
Net Weight Berat Bersih 净重	1.3 - 1.6kg (2.7 - 3.4lbs)
Work Amount (approx.) Jumlah Kerja 工作量	800 pcs with BL1850B Wood screw ø4.3 x 65mm

DTD153RTE | DTD153RFE | DTD153Z

Cordless Impact Driver
Pemutar Skru Impak Tanpa Kord
充电式冲击螺丝起子机



- Aluminum hammer case creates the impression of rigidity of the machine

Standard Equipment: Belt Clip

- RTE: 1x Rapid Charger, 2x 5.0Ah Battery
- RFE: 1x Rapid Charger, 2x 3.0Ah Battery
- Z: Without Charger, Battery & Carrying Case



*Not applicable for Z model



Capacity Kapasiti 能力	Machine Screw: M4 - M8 (5/32" - 5/16") Standard Bolt: M5 - M16 (3/16" - 5/8") High Tensile Bolt: M5 - M14 (3/16" - 9/16") Coarse Thread (in length): 22 - 125mm (7/8" - 4-7/8")
Hex Shank Batang Heksagon 六角柄	6.35mm (1/4")
No Load Speed (RPM) Kelajuan Tanpa Beban 回转数	0 - 3,400
Impacts Per Minute (IPM) Impak Per Minit 冲击数	0 - 3,600
Max Fastening Torque Maksimum Tenaga Pemutaran Pengancing 最大紧固扭力	170N-m (1,500in.lbs.)
Dimensions (L x W x H) Dimensi 体积	126x79x238mm (5"x3-1/8"x9-3/8")
Net Weight Berat Bersih 净重	1.3 - 1.6kg (2.8 - 3.5lbs)
Work Amount (approx.) Jumlah Kerja 工作量	760 pcs with BL1850B Wood screw 65mm

* All list price shown are for reference only (exclude SST).

* Semua harga yang ditunjukkan adalah untuk rujukan sahaja (tidak termasuk SST). 所有显示的建议零售价仅供参考 (不包括SST)。

Cordless
Tanpa Kord / Cordless

LED Flashlight
Lampu Saku LED
LED手电筒

Vacuum Cleaner
Pembersih Vakuum
吸尘器

Drilling / Fastening
Gantuli / Pengancing
钻孔 / 紧固

Impact Drilling / Demolition
Gantuli / Penusuk
冲击钻孔 / 拆墙施工

Cutting
Pemotong
切割

Grinding / Sanding
Pengamiran / Pechin
打磨 / 砂磨

Sawing
Gergaji
锯切

Planing / Routing
Pengayutan / Tanggapan
刨平 / 压边

Others
Lain-lain
其他

Outdoor Power Equipment
Alatan Kerja Luar
园机 / 户外

makita
MAKITA

18V

LXT

Li-ion Ah 6.0 5.0 4.0 3.0 2.0 1.5

DTD149FE | DTD149Z

448

Cordless Impact Driver

Pemutar Skru Impak Tanpa Kord
充电式冲击螺丝起子机

- Developed for main applications such as tightening of self-drilling screws or light duty machine screws

Standard Equipment: Belt Clip

- RFE: 1x Rapid Charger, 2x 3.0Ah Battery
- Z: Without Charger, Battery & Carrying Case

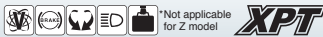

XPT



Capacity Kapasiti 能力	Machine Screw: M4 - M8 (5/32" - 5/16") Standard Bolt: M5 - M14 (3/16" - 9/16") High Tensile Bolt: M5 - M12 (3/16" - 1/2") Coarse Thread (in length): 22 - 125mm (7/8" - 4-7/8") 6.35mm (1/4")
Hex Shank Batang Heksagon 六角柄	
No Load Speed (RPM) Kelajuan Tanpa Beban 回转数	0 - 2,500
Impacts Per Minute (IPM) Impak Per Minit 冲击数	0 - 3,200
Max Fastening Torque Maksimum Tenaga Pemutaran Pengancing 最大紧固扭力	165N-m (1,460in.lbs.)
Dimensions (L x W x H) Dimensi 体积	135x79x238mm (5-5/16"x3-1/8"x9-3/8")
Net Weight Berat Bersih 淨重	1.3 - 1.6kg (2.8 - 3.5lbs)
Work Amount (approx.) Jumlah Kerja 工作量	533 pcs with BL1850B Wood screw Ø4.3 x 65mm

DTD152RME | DTD152RFE | DTD152Z

448

Cordless Impact Driver

Pemutar Skru Impak Tanpa Kord
充电式冲击螺丝起子机

- Aluminum hammer case creates the impression of rigidity of the machine

Standard Equipment: Belt Clip

- RME: 1x Rapid Charger, 2x 4.0Ah Battery
- RFE: 1x Rapid Charger, 2x 3.0Ah Battery
- Z: Without Charger, Battery & Carrying Case



XPT



Capacity Kapasiti 能力	Machine Screw: M4 - M8 (5/32" - 5/16") Standard Bolt: M5 - M16 (3/16" - 5/8") High Tensile Bolt: M5 - M12 (3/16" - 1/2") Coarse Thread (in length): 22 - 125mm (7/8" - 4-7/8") 6.35mm (1/4")
Hex Shank Batang Heksagon 六角柄	
No Load Speed (RPM) Kelajuan Tanpa Beban 回转数	0 - 2,900
Impacts Per Minute (IPM) Impak Per Minit 冲击数	0 - 3,500
Max Fastening Torque Maksimum Tenaga Pemutaran Pengancing 最大紧固扭力	165N-m (1,460 in.lbs.)
Dimensions (L x W x H) Dimensi 体积	137x79x238mm (5-3/8"x3-1/8"x9-3/8")
Net Weight Berat Bersih 淨重	1.3 - 1.6kg (2.8 - 3.5lbs)
Work Amount (approx.) Jumlah Kerja 工作量	603 pcs with BL1850B Hex screw 3/4" (Holding sheet 0.23mm RHS 1.6mm)

DTD156SF | DTD156Z

5

Cordless Impact Driver

Pemutar Skru Impak Tanpa Kord
充电式冲击螺丝起子机

- Compact, lightweight but powerful 4-pole motor

Standard Equipment: Belt Clip

- SF: 1x Standard Charger, 1x 3.0Ah Battery
- Z: Without Charger, Battery & Carrying Case



XPT



Capacity Kapasiti 能力	Machine Screw: M4 - M8 (5/32" - 5/16") Standard Bolt: M5 - M14 (3/16" - 9/16") High Strength Bolt: M5 - M12 (3/16" - 1/2") Coarse Thread (in length): 22 - 125mm (7/8" - 4-7/8")
Hex Shank Batang Heksagon 六角柄	6.35mm (1/4")
No Load Speed (RPM) Kelajuan Tanpa Beban 回转数	0 - 2,500
Impacts Per Minute (IPM) Impak Per Minit 冲击数	0 - 3,000
Max Fastening Torque Maksimum Tenaga Pemutaran Pengancing 最大紧固扭力	155N-m (1,370in.lbs.)
Dimensions (L x W x H) Dimensi 体积	143x79x241mm (5-5/8"x3-1/8"x9-1/2")
Net Weight Berat Bersih 淨重	1.3 - 1.6kg (2.9 - 3.6lbs.)
Work Amount (approx.) Jumlah Kerja 工作量	340 pcs with BL1830B Coarse thread screw 90mm into melapi

DTD157RAJ | DTD157Z

Cordless Impact Driver

Pemutar Skru Impak Tanpa Kord
充电式冲击螺丝起子机

- 3-mode operation for A-mode / Hard mode / Soft mode for multiple applications

Standard Equipment: Belt Clip,
Double Ended Twist Torsion Screw Bit

- RAJ: 1x Rapid Charger, 2x 2.0Ah Battery, 1x Makpac Connector Box
- Z: Without Charger, Battery & Carrying Case



BL MOTOR XPT



Capacity Keupayaan Pengancing 紧固能力	Machine Screw: M4 - M8mm (5/32" - 5/16") Standard Bolt: M5 - M14 (3/16" - 9/16") High Strength Bolt: M5 - M12 (3/16" - 1/2") Coarse thread (in length): 22 - 90mm (7/8" - 3-1/2") 6.35mm (1/4")
Hex Shank Skru Persegi 方形螺柱	
No Load Speed (RPM) Kelajuan Tanpa Beban 回转数	Hard: 0 - 3,000 Soft: 0 - 1,300
Impacts Per Minute (IPM) Impak Per Minit 冲击数	Hard: 0 - 4,100 Soft: 0 - 2,000
Max Fastening Torque Maksimum Tenaga Pemutaran Pengancing 最大紧固扭力	140N-m (1,240in.lbs.)
Dimensions (L x W x H) Dimensi 体积	133x81x232mm (5-1/4"x3-3/16"x9-1/8")
Net Weight Berat Bersih 淨重	1.2 - 1.5kg (2.6 - 3.3lbs.)
Work Amount (approx.) Jumlah Kerja 工作量	1200 pcs with BL1820B Coarse thread screw 90mm into melapi in hard impact mode

DTD155RME | DTD155Z

Cordless Impact Driver

Pemutar Skru Impak Tanpa Kord
充电式冲击螺丝起子机

- 3-Mode operation for A-mode / Hard mode / Soft mode for multiple applications

Standard Equipment: Belt Clip

- RME: 1x Rapid Charger, 2x 4.0Ah Battery
- Z: Without Charger, Battery & Carrying Case



BL MOTOR XPT



Capacity Kapasiti 能力	Machine Screw: M4 - M8 mm (5/32" - 5/16") Standard Bolt: M5 - M14 (3/16" - 9/16") High Tensile Bolt: M5 - M12 (3/16" - 1/2") Coarse Thread (in length): 22 - 90mm (7/8" - 3-1/2") 6.35mm (1/4")
Hex Shank Batang Heksagon 六角柄	
No Load Speed (RPM) Kelajuan Tanpa Beban 回转数	Hard: 0 - 3,000 Soft: 0 - 1,300
Impacts Per Minute (IPM) Impak Per Minit 冲击数	Hard: 0 - 3,900 Soft: 0 - 1,600
Max Fastening Torque Maksimum Tenaga Pemutaran Pengancing 最大紧固扭力	140N-m (1,240in.lbs.)
Dimensions (L x W x H) Dimensi 体积	135x79x232mm (5-5/16"x3-1/8"x9-1/8")
Net Weight Berat Bersih 淨重	1.2 - 1.5kg (2.6 - 3.2lbs)
Work Amount (approx.) Jumlah Kerja 工作量	725 pcs with BL1850B Coarse thread screw 65mm (melapi)

* All list price shown are for reference only (exclude SST).

* Semua harga yang ditunjukkan adalah untuk rujukan sahaja (tidak termasuk SST). 所有显示的建议零售价仅供参考 (不包括SST)。



Li-ion Ah 6.0 5.0 4.0 3.0 2.0 1.5

DTP141RFE | DTP141Z

Cordless 4 Mode Impact Driver

Pemutar Skru Impak Tanpa Kord
充电式冲击螺丝起子机



- 4 Operation Modes (Impact Driver, Hammer Drill, Drill, Screwdriver) and Teks Screw Mode selection

Standard Equipment: Belt Clip

- RFE: 1x Rapid Charger, 2x 3.0Ah Battery
- Z: Without Charger, Battery & Carrying Case



Capacity Kapasiti 能力	Steel: 10mm (3/8") / Wood: 21mm (13/16") Masonry: 8mm (5/16")
No Load Speed (RPM) Kelajuan Tanpa Beban 回转数	Impact-driver Mode: Hard: 0 - 2,700 Medium: 0 - 2,200 Soft: 0 - 1,300 Drill Mode High: 0 - 2,700 Low: 0 - 700 Hammer Drill Mode High: 0 - 2,700 Low: 0 - 700 Screwdriver Mode High: 0 - 1,100 Low: 0 - 300
Impacts Per Minute (IPM) Impak Per Minit 冲击数	Impact-driver Mode (Hard: 0-3,200 Medium: 0-2,400 Soft: 0-1,200) Hammer Drill Mode (Hi: 0 - 32,400 Lo: 0 - 8,400)
Max Fastening Torque Maksimum Tenaga Pemutaran Pengancing 最大紧固扭力	Impact-driver Mode: 150N-m (1,330in.lbs.) Drill Mode (Hard/ Soft): 22/ 13N-m
Dimensions (L x W x H) Dimensi 体积	171x79x250mm (6-3/4"x3-1/8"x9-7/8")
Net Weight Berat Bersih 净重	1.5 - 1.9kg (3.4 - 4.1lbs)

DTS141RFE | DTS141Z

Cordless Oil-Pulse Driver

Pemutar Skru Impak Tanpa Kord
充电式冲击螺丝起子机



- Low noise level of 77dB

Standard Equipment: Belt Clip

- RFE: 1x Rapid Charger, 2x 3.0Ah Battery
- Z: Without Charger, Battery & Carrying Case



Capacity Kapasiti 能力	Machine Screw: M4 - M8 (5/32" - 5/16") Standard Bolt: M5 - M8 (3/16" - 5/16") High Tensile Bolt: M5 - M6 (3/16" - 1/4") Coarse Thread (in length): 22 - 125mm (7/8" - 4-7/8") Hard: 0-3,200 Medium: 0-2,000 Soft: 0-1,200
No Load Speed (RPM) Kelajuan Tanpa Beban 回转数	
Impacts Per Minute (IPM) Impak Per Minit 冲击数	Hard: 0-2,700 Medium: 0-2,200 Soft: 0-1,400
Max Fastening Torque Maksimum Tenaga Pemutaran Pengancing 最大紧固扭力	40N-m (355in.lbs.)
Dimensions (L x W x H) Dimensi 体积	136x79x240mm (5-3/8"x3-1/8"x9-1/2")
Net Weight Berat Bersih 净重	1.3 - 1.6kg (2.8 - 3.5lbs)
Work Amount (approx.) Jumlah Kerja 工作量	750 pcs with BL1850B Wood screw ø4.3 x 65mm

Model No. 型号	No Load Speed (rpm) Kelajuan Tanpa Beban 回转数	Impacts Per Minute (IPM) Impak Per Minit 冲击数	Electronic Speed Kelajuan Elektronik 电子速度	Max. Fastening Torque (N.m) Maksimum Tenaga Pemutaran Pengancing 最大紧固扭力	Overall Length (mm) Panjang Keseluruhan 总长度	Net Weight Berat Bersih 净重	BL MOTOR	XPT
Cordless Impact Driver								
DTD172	0 - 3,600 / 3,200 / 2,100 / 1,100 / 1,800 / 3,600 / 2,900 / 3,600	0 - 3,800 / 3,600 / 2,600 / 1,100 / 3,800 / 3,800 / N/A / 2,600	4	180	114	1.2kg (2.6lbs)	●	●
DTD171	0 - 3,600 / 3,200 / 2,100 / 1,100 / 1,800 / 3,600 / 2,900 / 3,600	0 - 3,800 / 3,600 / 2,600 / 1,100 / 3,800 / 3,800 / N/A / 2,600	4	180	116	1.2kg (2.7lbs)	●	●
DTD170	0 - 3,600 / 3,200 / 2,100 / 1,100 / 3,600	0 - 3,800 / 3,600 / 2,600 / 1,100 / 2,600	4	175	117	1.2kg (2.7lbs)	●	●
DTD154	0 - 3,600 / 0 - 2,100 / 0 - 1,100	0 - 3,800 / 0 - 2,600 / 0 - 1,100	3	175	117	1.3kg (2.7lbs)	●	●
DTD153	0 - 3,400	0 - 3,600	-	170	126	1.3kg (2.8lbs)	●	●
DTD149	0 - 2,500	0 - 3,200	-	165	135	1.3kg (2.8lbs)	●	●
DTD152	0 - 2,900	0 - 3,500	-	165	137	1.3kg (2.8lbs)	●	●
DTD156	0 - 2,500	0 - 3,000	-	155	143	1.3kg (2.9lbs)	●	●
DTD157	0 - 3,000 / 0 - 1,300	0 - 4,100 / 0 - 2,000	2	140	133	1.2kg (2.6lbs)	●	●
DTD155	0 - 3,000 / 0 - 1,300	0 - 3,900 / 0 - 1,600	2	140	135	1.2kg (2.6lbs)	●	●
Cordless 4 Mode Impact Driver (Impact-driver mode)								
DTP141	0-2,700/ 0-2,200/ 0-1,300	0-3,200/ 0-2,400/ 0-1,200	3	150	171	1.5kg (3.4lbs)	●	●
Cordless Oil-Pulse Drive								
DTS141	0-3,200/ 0-2,000/ 0-1,200	0-2,700/ 0-2,200/ 0-1,400	3	40	136	1.3kg (2.8lbs)	●	●

DTL061Z

Cordless Angle Impact Driver

Pemutar Skru Impak Sudut
Tanpa Kord
充电式角向冲击螺丝起子机



- 360 degrees rotatable head enables operation from optimum angle

Standard Equipment: Belt Clip

- Z: Without Charger & Battery



Capacity Kapasiti 能力	Machine Screw: M4 - M8 (5/32" - 5/16") Standard Bolt: M4 - M12 (5/32" - 1/2") High Tensile Bolt: M4 - M8 (5/32" - 5/16") Coarse Thread (in length): 22 - 75mm (7/8" - 2-31/32") 6.35mm (1/4")
Hex Shank Batang Heksagon 六角柄	
No Load Speed (RPM) Kelajuan Tanpa Beban 回转数	0 - 2,000
Impacts Per Minute (IPM) Impak Per Minit 冲击数	0 - 3,000
Max Fastening Torque Maksimum Tenaga Pemutaran Pengancing 最大紧固扭力	60N-m (530in.lbs.)
Dimensions (L x W x H) Dimensi 体积	387x78x116mm (15-1/4"x3-1/16"x4-9/16")
Net Weight Berat Bersih 净重	1.4 - 2.0kg (3.1 - 4.3lbs)
Work Amount (approx.) Jumlah Kerja 工作量	350 pcs with BL1850B Wood Screw 4.2 x 65mm

DDA450Z

Cordless Angle Drill

Gerudi Sudut Tanpa Kord
充电式角向电钻



- Compact and lightweight for increased maneuverability in various work postures and reduced user fatigue

Standard Equipment:

- Chuck Key, Chuck Key Holder, Side Grip, Hook, + Screw

- Z: Without Charger & Battery



Capacity Kapasiti 能力	Steel: 13mm (1/2") Wood (Auger-Bit): 38mm (1-1/2") Wood (Hole Saw) Hi: 101mm (4") Wood (Hole Saw) Lo: 127mm (5") Wood (Self-Feed Bit) Hi: 50mm (2") Wood (Self-Feed Bit) Lo: 65mm (2-9/16") 2 - 13mm (1/16 - 1/2")
Chuck Capacity Kapasiti Chuck 夹头能力	
No Load Speed (RPM) Kelajuan Tanpa Beban 回转数	High: 0 - 1,400 Low: 0 - 450
Max Fastening Torque Maksimum Tenaga Pemutaran Pengancing 最大紧固扭力	High: 26N-m (230in.lbs.) Low: 70N-m (620in.lbs.)
Dimensions (L x W x H) Dimensi 体积	434x82x179mm (17-1/8x3-1/4x7")
Net Weight Berat Bersih 净重	3.2 - 3.5kg (7.1 - 7.7lbs.)
Work Amount (approx.) Jumlah Kerja 工作量	125 holes with BL1860B 2 layer of SPF 2 x 10 plate

* All list price shown are for reference only (exclude SST).

* Semua harga yang ditunjukkan adalah untuk rujukan sahaja (tidak termasuk SST). 所有显示的建议零售价仅供参考 (不包括SST)。

Cordless
Targeted Jobs

LED Flashlight
Lampu Saku LED
LED手电筒

Vacuum Cleaner
Pembersih Vakuum
吸尘器

Drilling / Fastening
Gerudi / Pengancing
钻孔 / 紧固

Impact Drilling / Demolition
Gerudi Impak / Pencahayaan
冲击钻孔 / 冲击施工

Cutting
Pemotong
切割

Grinding / Sanding
Pengamiran / Pemoles
打磨 / 砂磨

Sawing
Gergaji
锯切

Planing / Routing
Pengamiran / Tumpang
刨削 / 压花

Others
Lain-lain
其他

Outdoor Power Equipment
Alatan Kuat Luar
户外动力设备

Thakita
TENT

18V

LXT

Li-ion Ah 6.0 5.0 4.0 3.0 2.0 1.5

DDA351Z 10mm (3/8")

440

Cordless Angle Drill
Gerudi Sudut Tanpa Kord
充电式角向电钻

- Original 4-pole motor for power, lightweight and compact size



Standard Equipment: Side Grip

- Z: Without Charger & Battery



Capacity Kapasiti 能力	Steel: 10mm (3/8") Wood: 25mm (1")
No Load Speed (RPM) Kelajuan Tanpa Beban 回转数	0-1,800
Dimensions (L x W x H) Dimensi 体积	326x79x115mm (12-7/8"x3-1/8"x4-1/2")
Net weight Berat Bersih 淨重	1.6 - 1.9kg (4.2 - 3.5lbs)
Work Amount (approx.) Jumlah Kerja 工作量	1000 pcs with BL1850B Wood Screw ø5.1 x 38mm

DFS452Z

Cordless Screwdriver
Pemutar Skru Tanpa Kord
充电式螺丝起子机

- Push Drive Technology for Quieter Operation;
Minimizes Power Consumption



Standard Equipment: Phillips Bit, Magnetic Bit Holder, Belt Clip

- Z: Without Charger & Battery



Capacity Kapasiti 能力	Self-Drilling Screw: 6mm (1/4") Drywall Screw: 5mm (3/16") 6.35mm (1/4")
Driving Shank (Hex) Hex Memandu Aci 六角驱动轴	
No Load Speed (RPM) Kelajuan Tanpa Beban 回转数	0 - 4,000
Dimensions (L x W x H) Dimensi 体积	251x79x259mm (10"x3-1/8"x11-1/4")
Net weight Berat Bersih 淨重	1.5 - 1.8kg (3.2 - 3.9lbs)
Work Amount (approx.) Jumlah Kerja 工作量	2325 pcs with BL1850B Wood Screw 1.0 x 32mm

DFS250RTE | DFS250RFE | DFS250Z

Cordless Screwdriver
Pemutar Skru Tanpa Kord
充电式螺丝起子机

- Ultra-high efficiency comparable to AC screwdrivers



Standard Equipment: Phillips Bit, Magnetic Bit Holder, Belt Clip

- RTE: 1x Rapid Charger, 2x 5.0Ah Battery
- RFE: 1x Rapid Charger, 2x 3.0Ah Battery
- Z: Without Charger, Battery & Carrying Case

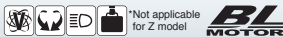

Capacity Kapasiti 能力	Coarse Thread: 4.5 x 90mm (3/16" x 3-1/2") Self-Drilling Screw: 6mm (1/4") Drywall Screw: 5mm (3/16") 6.35mm (1/4")
Driving Shank (Hex) Hex Memandu Aci 六角驱动轴	
No Load Speed (RPM) Kelajuan Tanpa Beban 回转数	0 - 2,500
Dimensions (L x W x H) Dimensi 体积	259x79x259mm (10-1/4"x3-1/8"x10-1/4")
Net weight Berat Bersih 淨重	1.5 - 1.9kg (3.4 - 4.1lbs)
Work Amount (approx.) Jumlah Kerja 工作量	1091 pcs with BL1850B Wood Screw 8" x 1" (Pine Wood)

DFS251RTE | DFS251RFE | DFS251Z

Cordless Screwdriver
Pemutar Skru Tanpa Kord
充电式螺丝起子机

- High torque ideal for fastening self-drilling screw



Standard Equipment: Magnetic Socket Bit, Belt Clip

- RTE: 1x Rapid Charger, 2x 5.0Ah Battery
- RFE: 1x Rapid Charger, 2x 3.0Ah Battery
- Z: Without Charger, Battery & Carrying Case

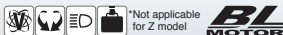

Capacity Kapasiti 能力	Self-Drilling Screw: 6mm (1/4") Drywall Screw: 5mm (3/16") Hex Socket Screw: 6mm (1/4")
Driving Shank (Hex) Hex Memandu Aci 六角驱动轴	6.35mm (1/4")
No Load Speed (RPM) Kelajuan Tanpa Beban 回转数	0 - 2,500
Dimensions (L x W x H) Dimensi 体积	237x79x259mm (9-3/8"x3-1/8"x11-1/4")
Net weight Berat Bersih 淨重	1.5 - 1.8kg (3.2 - 3.9lbs)
Work Amount (approx.) Jumlah Kerja 工作量	1091 pcs with BL1850B Wood Screw 8" x 1" (Pine Wood)

DFR550Z

440

Cordless Auto Feed
Screwdriver
Pemutar Skru Suapan Auto
Tanpa Kord
充电式自动螺丝起子机

- Ideal for drywall and subfloors



Standard Equipment: Phillips Bit x3

- Z: Without Charger & Battery



Screw Strip Kapasiti 能力	4 x 25 - 55mm (5/32" x 1" - 2-3/16")
Driving Shank (Hex) Hex Memandu Aci 六角驱动轴	6.35mm (1/4")
No Load Speed (RPM) Kelajuan Tanpa Beban 回转数	4,000
Dimensions (L x W x H) Dimensi 体积	424x80x238mm (16-3/4"x3-1/8"x9-3/8")
Net weight Berat Bersih 淨重	2.1 - 3.1kg (4.6 - 6.9lbs)
Work Amount (approx.) Jumlah Kerja 工作量	1166 pcs with BL1850B Wood Screw 35mm (1-3/8") (plasterboard into Douglas-fir timber)

* All list price shown are for reference only (exclude SST).

* Semua harga yang ditunjukkan adalah untuk rujukan sahaja (tidak termasuk SST). 所有显示的建议零售价仅供参考 (不包括SST)。

Cordless
Tanpa Kord 无绳式LED Flashlight
Lampu Suluh LED
LED 照明灯Vacuum Cleaner
Pembersih Vakuum
吸尘器Drilling / Fastening
Ganjal / Pasang
钻孔 / 紧固Impact Drilling / Demolition
Ganjal / Perseki
起工钻孔 / 拆墙加工Cutting
Pemotong
切割Grinding / Sanding
Pengisar / Pasir
磨削 / 打磨Sawing
Gergaji
锯切Planing / Routing
Pengisar / Tampam
刨削 / 雕刻Others
Lain-lain
其他Outdoor Power Equipment
Alatan Kerja Luar
园林-户外Makita
MAKITA

BRUSHLESS MOTOR

Motor tanpa berus 无碳刷马达

- Maintenance-free due to no brush
 - Life time work amount of a battery is increased
 - Durable against long continuous operation
 - More work amount on a single full battery charge
- pengalangan mudah tanpa proses penggantian berus karbon
 Alat yang menggunakan motor berus BL tidak mengalami
 geseran haba, dengan itu menjadikan bateri lebih tahan lama
 免却更换碳刷的高频工序, 保养更轻松简单
 采用BL无碳刷马达的工具没有因摩擦热导致的能量流失,
 所以每次充电后的连续工作时间更长



BRUSHED MOTOR

Motor dengan berus 有刷马达

- High power-to-weight ratio obtained by employing 4-pole motor
- Berkuasa tinggi dengan motor 4-pole
 采用4极马达, 高功率



4-POLE MOTOR

2-POLE MOTOR

Max Fastening Torque

Tenaga Pemutaran Pengancing Maksimum 最大紧固扭矩

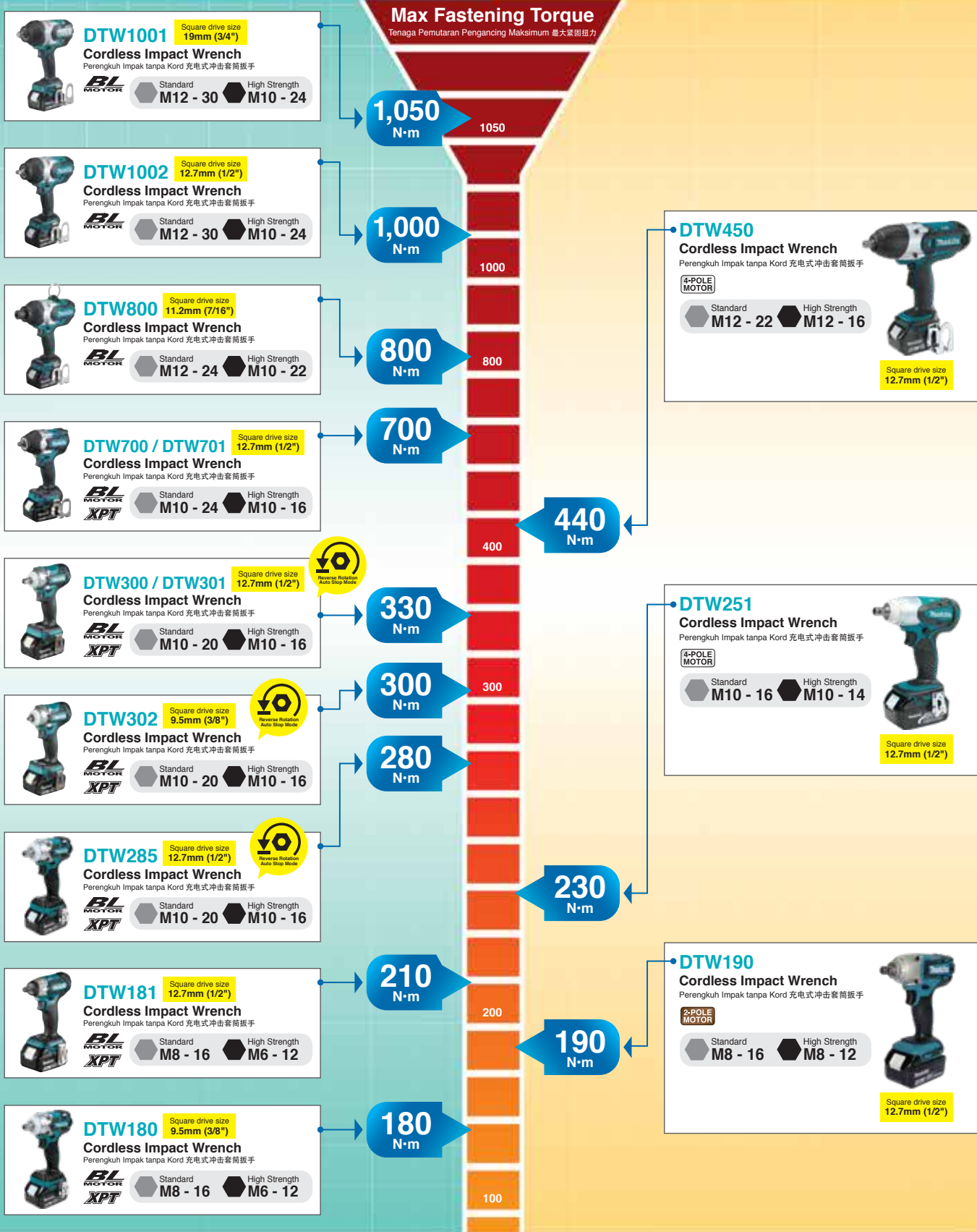

* All list price shown are for reference only (exclude SST).

* Semua harga yang ditunjukkan adalah untuk rujukan sahaja (tidak termasuk SST). 所有显示的建议零售价仅供参考 (不包括SST)。

Cordless
Tangkas Tanpa Kord

LED Flashlight
Lampu Suhu LED
LED 闪光灯

Vacuum Cleaner
Pembersih Vakuum
吸尘器

Drilling / Fastening
Ganda / Pengasih
钻孔 / 紧固

Impact Drilling / Demolition
Ganda / Pemusnah
钻孔 / 摧毁

Cutting
Pemotong
切割

Grinding / Sanding
Pengisar / Pemoles
打磨 / 砂磨

Sawing
Gergaji
锯切

Planing / Routing
Pengaliran / Tanggapan
刨平 / 雕刻

Others
Lain-lain
其他

Outdoor Power Equipment
Alatan Kuasa Luar
户外动力设备

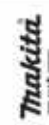



Li-ion Ah 6.0 | 5.0 | 4.0 | 3.0 | 2.0 | 1.5

DTW1001RTJ | DTW1001RMJ | DTW1001RFJ | DTW1001Z 19mm (3/4")

Cordless Impact Wrench
Perengkuh Impak Tanpa Kord
充电式冲击套筒扳手



- Makita's Most Powerful Impact Wrench
- Standard Equipment: Hook
- RTJ : 1x Rapid Charger, 2x 5.0Ah Battery, 1x Makpac Connector Box
- RMJ : 1x Rapid Charger, 2x 4.0Ah Battery, 1x Makpac Connector Box
- RFJ : 1x Rapid Charger, 2x 3.0Ah Battery, 1x Makpac Connector Box
- Z : Without Charger, Battery & Carrying Case

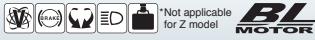

Fastening Capacities Keupayaan Pengancing 紧固能力	Standard Bolt: M12 - M30 (1/2" - 1-1/4") High Tensile Bolt: M10 - M24 (3/8" - 1")
Square Drive Skrus Persegi 方形螺栓	19mm (3/4")
No Load Speed (RPM) Kelajuan Tanpa Beban 回转数	Hard: 0 - 1,800 Medium: 0 - 1,000 Soft: 0 - 900
Impacts Per Minute (IPM) Impak Per Minit 冲击数	Hard: 0 - 2,200 Medium : 0 - 2,000 Soft: 0 - 1,800
Max Fastening Torque Tenaga Pemutaran Pengancing Maksimum 最大紧固扭力	1,050N-m (780ft.lbs.)
Nut-Busting Torque Tork Pembongkaran Maksimum 最大拆卸扭力	1,700N-m (1,250ft.lbs.)
Dimensions (L x W x H) Dimensi 体积	229x91x289mm (9"x3-5/8"x11-3/8")
Net Weight Berat Bersih 淨重	3.4 - 3.7kg (7.5 - 8.2lbs)
Work Amount (approx.) Jumlah Kerja 工作量	185 pcs with BL1850B Bolts M20

DTW1002RTJ | DTW1002RMJ | DTW1002RFJ | DTW1002Z 12.7mm (1/2")

Cordless Impact Wrench
Perengkuh Impak Tanpa Kord
充电式冲击套筒扳手



- Efficient impact system (Max 2,200 IPM) with less vibration

Standard Equipment: Hook

- RTJ : 1x Rapid Charger, 2x 5.0Ah Battery, 1x Makpac Connector Box
- RMJ : 1x Rapid Charger, 2x 4.0Ah Battery, 1x Makpac Connector Box
- RFJ : 1x Rapid Charger, 2x 3.0Ah Battery, 1x Makpac Connector Box
- Z : Without Charger, Battery & Carrying Case

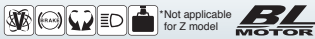

Fastening Capacities Keupayaan Pengancing 紧固能力	Standard Bolt: M12 - M30 (1/2" - 1-1/4") High Tensile Bolt: M10 - M24 (3/8" - 1")
Square Drive Skrus Persegi 方形螺栓	12.7mm (1/2")
No Load Speed (RPM) Kelajuan Tanpa Beban 回转数	Hard: 0 - 1,800 Medium: 0 - 1,000 Soft: 0 - 900
Impacts Per Minute (IPM) Impak Per Minit 冲击数	Hard: 0 - 2,200 Medium : 0 - 2,000 Soft: 0 - 1,800
Max Fastening Torque Tenaga Pemutaran Pengancing Maksimum 最大紧固扭力	1,000N-m (740ft.lbs.)
Nut-Busting Torque Tork Pembongkaran Maksimum 最大拆卸扭力	1,600N-m (1,180ft.lbs.)
Dimensions (L x W x H) Dimensi 体积	229x91x289mm (9"x3-5/8"x11-3/8")
Net Weight Berat Bersih 淨重	3.3 - 3.6kg (7.3 - 8.0lbs)
Work Amount (approx.) Jumlah Kerja 工作量	185 pcs with BL1850B Bolts M20

DTW800RMJ | DTW800RFJ | DTW800Z 11.2mm (7/16")

Cordless Impact Wrench
Perengkuh Impak Tanpa Kord
充电式冲击套筒扳手



- Extremely high power 800N-m (590ft.lbs.) way ahead of competitors

Standard Equipment: Hook

- RMJ : 1x Rapid Charger, 2x 4.0Ah Battery, 1x Makpac Connector Box
- RFJ : 1x Rapid Charger, 2x 3.0Ah Battery, 1x Makpac Connector Box
- Z : Without Charger, Battery & Carrying Case

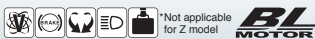

Fastening Capacities Keupayaan Pengancing 紧固能力	Standard Bolt: M12 - M24 (1/2" - 1") High Tensile Bolt: M10 - M22 (3/8" - 7/8")
Hex Shank Skrus Persegi 方形螺栓	11.1mm (7/16")
No Load Speed (RPM) Kelajuan Tanpa Beban 回转数	Hard: 0 - 1,800 Medium: 0 - 1,000 Soft: 0 - 900
Impacts Per Minute (IPM) Impak Per Minit 冲击数	Hard: 0 - 2,200 Medium : 0 - 2,000 Soft: 0 - 1,800
Max Fastening Torque Tenaga Pemutaran Pengancing Maksimum 最大紧固扭力	800N-m (590ft.lbs.)
Dimensions (L x W x H) Dimensi 体积	229x91x303mm (9"x3-5/8"x11-7/8")
Net Weight Berat Bersih 淨重	3.4 - 3.7kg (8.2 - 7.5lbs)
Work Amount (approx.) Jumlah Kerja 工作量	27 holes with BL1850B Auger Drill ø13/16" (Drill 300mm Douglas-fir)

DTW701RTJ | DTW701Z 12.7mm (1/2")

Cordless Impact Wrench
Perengkuh Impak Tanpa Kord
充电式冲击套筒扳手



- 3 modes of reaction time for automatic stop available both in forward and reverse rotation modes

Standard Equipment: Hook

- RTJ : 1x Rapid Charger, 2x 5.0Ah Battery, 1x Makpac Connector Box
- Z : Without Charger, Battery & Carrying Case



Fastening Capacities Keupayaan Pengancing 紧固能力	Standard Bolt: M10 - M24 (3/8 - 1") High Strength Bolt (Grade 10.9): M10 - M16 (3/8 - 5/8") High Strength Bolt (Grade F10T): M12, M16 (7/16, 5/8")
Square Drive Skrus Persegi 方形螺栓	12.7mm (1/2")
No Load Speed (RPM) Kelajuan Tanpa Beban 回转数	Max: 0 - 2,200 Hard: 1,900 Medium: 1,200 Soft: 500
Impacts Per Minute (IPM) Impak Per Minit 冲击数	Max: 0 - 2,700 Hard: 2,400 Medium: 1,700 Soft: 1,000
Max Fastening Torque Tenaga Pemutaran Pengancing Maksimum 最大紧固扭力	700N-m (520ft.lbs.)
Nut-Busting Torque Tork Pembongkaran Maksimum 最大拆卸扭力	1,000N-m (740ft.lbs.)
Dimensions (L x W x H) Dimensi 体积	170x81x276mm (6-11/16x3-3/16x10-7/8")
Net Weight Berat Bersih 淨重	2.3 - 2.7kg (5.1 - 6.0lbs.)

DTW700RTJ | DTW700Z 12.7mm (1/2")

Cordless Impact Wrench
Perengkuh Impak Tanpa Kord
充电式冲击套筒扳手



- 3 modes of reaction time for automatic stop available both in forward and reverse rotation modes

Standard Equipment: Hook

- RTJ : 1x Rapid Charger, 2x 5.0Ah Battery, 1x Makpac Connector Box
- Z : Without Charger, Battery & Carrying Case



Fastening Capacities Keupayaan Pengancing 紧固能力	Standard Bolt: M10 - M24 (3/8 - 1") High Strength Bolt (Grade 10.9): M10 - M16 (3/8 - 5/8") High Strength Bolt (Grade F10T): M12, M16 (7/16, 5/8")
Square Drive Skrus Persegi 方形螺栓	12.7mm (1/2")
No Load Speed (RPM) Kelajuan Tanpa Beban 回转数	Max: 0 - 2,200 Hard: 1,900 Medium: 1,200 Soft: 500
Impacts Per Minute (IPM) Impak Per Minit 冲击数	Max: 0 - 2,700 Hard: 2,400 Medium: 1,700 Soft: 1,000
Max Fastening Torque Tenaga Pemutaran Pengancing Maksimum 最大紧固扭力	700N-m (520ft.lbs.)
Nut-Busting Torque Tork Pembongkaran Maksimum 最大拆卸扭力	1,000N-m (740ft.lbs.)
Dimensions (L x W x H) Dimensi 体积	170x81x276mm (6-11/16x3-3/16x10-7/8")
Net Weight Berat Bersih 淨重	2.3 - 2.7kg (5.1 - 6.0lbs.)

* All list price shown are for reference only (exclude SST).

* Semua harga yang ditunjukkan adalah untuk rujukan sahaja (tidak termasuk SST). 所有显示的建议零售价仅供参考 (不包括SST)。

18V

LXT

Li-ion Ah 6.0 5.0 4.0 3.0 2.0 1.5



Adjustable overall length
Telescopic pipe section is adjustable to user's height in 5 stages by pulling the knob
Overall length: 657mm - 807mm
Range of motion: 150mm

Large two-finger trigger
ideal for continuous operation

Hex wrench can be stored
on the main handle

Loop handle
Auxiliary loop handle provides added control to make it easy to fit the tool socket on a target bolt

ACCESSORIES (Optional)
Extension Handle Set
Part No. 191G67-2

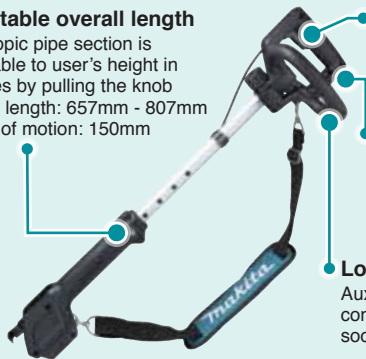

DTW450RME DTW450RFE DTW450Z 12.7mm (1/2") **441**

Cordless Impact Wrench
Perengkuh Impak Tanpa Kord
充电式冲击套筒扳手

• Compact and lightweight design provide superior balance and control

Standard Equipment: Hook

- RME: 1x Rapid Charger, 2x 4.0Ah Battery
- RFE: 1x Rapid Charger, 2x 3.0Ah Battery
- Z: Without Charger, Battery & Carrying Case



Fastening Capacities Keupayaan Pengancing 紧固能力	Standard Bolt: M12 - M22 (1/2" - 7/8") High Tensile Bolt: M12 - M16 (1/2" - 5/8") 12.7mm (1/2")
Square Drive Skrus Persegi 方形螺栓	
No Load Speed (RPM) Kelajuan Tanpa Beban 回转数	1,600
Impacts Per Minute (IPM) Impak Per Minit 冲击数	2,200
Max Fastening Torque Tenaga Pemutaran Pengancing Maksimum 最大紧固扭力	440N-m (325 ft.lbs.)
Nut-Busting Torque Tork Pembongkaran Maksimum 最大拆卸扭力	730N-m (545ft.lbs.)
Dimensions (L x W x H) Dimensi 体积	266x82x290mm (10-1/2"x3-1/4"x11-3/8")
Net Weight Berat Bersih 净重	3.1 - 3.4kg (7.6 - 6.9lbs)
Work Amount (approx.) Jumlah Kerja 工作量	120 pcs with BL1850B Bolts M16

DTW301RTJ DTW301Z DTW300RTJ DTW300Z 12.7mm (1/2")

Cordless Impact Wrench
Perengkuh Impak Tanpa Kord
充电式冲击套筒扳手

• 3 modes of reaction time for automatic stop available both in forward and reverse rotation modes

Standard Equipment: Belt Clip, Tool Catcher Set with Shoulder Belt (197941-0)

- RTJ: 1x Rapid Charger, 2x 5.0Ah Battery, 1x Makpac Connector Box
- Z: Without Charger, Battery & Carrying Case



Reverse Rotation Auto Stop Mode
Mod auto berhenti untuk putaran terbalik 反转自动停止模式

Fastening Capacities Keupayaan Pengancing 紧固能力	High Strength Bolt: M10 - M16 (3/8" - 5/8") Standard Bolt: M10 - M20 (3/8" - 3/4") 12.7mm (1/2")
Square Drive Skrus Persegi 方形螺栓	
No Load Speed (RPM) Kelajuan Tanpa Beban 回转数	Max: 0 - 3,200 Hard: 2,600 Medium: 1,800 Soft: 1,000
Impacts Per Minute (IPM) Impak Per Minit 冲击数	Max: 0 - 4,000 Hard: 3,400 Medium: 2,600 Soft: 1,800
Max Fastening Torque Tenaga Pemutaran Pengancing Maksimum 最大紧固扭力	330N-m (240ft.lbs.)
Nut-Busting Torque Tork Pembongkaran Maksimum 最大拆卸扭力	580N-m (430ft.lbs.)
Dimensions (L x W x H) Dimensi 体积	144x81x246mm (5-5/8"x3-3/16"x9-11/16")
Net Weight Berat Bersih 净重	1.5 - 1.8kg (3.4 - 4.1lbs.)

DTW302RTJ DTW302Z 9.5mm (3/8")

Cordless Impact Wrench
Perengkuh Impak Tanpa Kord
充电式冲击套筒扳手

• 3 modes of reaction time for automatic stop available both in forward and reverse rotation modes

Standard Equipment: Belt Clip, Tool Catcher Set with Shoulder Belt (197941-0)

- RTJ: 1x Rapid Charger, 2x 5.0Ah Battery, 1x Makpac Connector Box
- Z: Without Charger, Battery & Carrying Case



Reverse Rotation Auto Stop Mode
Mod auto berhenti untuk putaran terbalik 反转自动停止模式

Fastening Capacities Keupayaan Pengancing 紧固能力	High Strength Bolt: M10 - M16 (3/8" - 5/8") Standard Bolt: M10 - M20 (3/8" - 3/4") 9.5mm (3/8")
Square Drive Skrus Persegi 方形螺栓	
No Load Speed (RPM) Kelajuan Tanpa Beban 回转数	Max: 0 - 3,200 Hard: 0 - 2,600 Medium: 0 - 1,800 Soft: 0 - 1,000
Impacts Per Minute (IPM) Impak Per Minit 冲击数	Max: 0 - 4,000 Hard: 0 - 3,400 Medium: 0 - 2,600 Soft: 0 - 1,800
Max Fastening Torque Tenaga Pemutaran Pengancing Maksimum 最大紧固扭力	300N-m (220ft.lbs.)
Nut-Busting Torque Tork Pembongkaran Maksimum 最大拆卸扭力	500N-m (370ft.lbs.)
Dimensions (L x W x H) Dimensi 体积	138x81x246mm (5-7/16"x3-3/16"x9-11/16")
Net Weight Berat Bersih 净重	1.4 - 1.8kg (3.1 - 4.0lbs.)

DTW285RFE DTW285Z 12.7mm (1/2")

Cordless Impact Wrench
Perengkuh Impak Tanpa Kord
充电式冲击套筒扳手

• BL motor delivers 280N-m of max torque

Standard Equipment: Belt Clip

- RFE: 1x Rapid Charger, 2x 3.0Ah Battery
- Z: Without Charger, Battery & Carrying Case



Reverse Rotation Auto Stop Mode
Mod auto berhenti untuk putaran terbalik 反转自动停止模式

Fastening Capacities Keupayaan Pengancing 紧固能力	Standard Bolt: M10 - M20 (3/8" - 3/4") High Tensile Bolt: M10 - M16 (3/8" - 5/8") 12.7mm (1/2")
Square Drive Skrus Persegi 方形螺栓	
No Load Speed (RPM) Kelajuan Tanpa Beban 回转数	Hard: 0 - 2,800 Medium: 0 - 2,100 Soft: 0 - 1,600
Impacts Per Minute (IPM) Impak Per Minit 冲击数	Hard: 0 - 3,500 Medium: 0 - 2,600 Soft: 0 - 1,800
Max Fastening Torque Tenaga Pemutaran Pengancing Maksimum 最大紧固扭力	280N-m (210ft.lbs.)
Nut-Busting Torque Tork Pembongkaran Maksimum 最大拆卸扭力	500N-m (370ft.lbs.)
Dimensions (L x W x H) Dimensi 体积	147x79x249mm (5-3/4"x3-1/8"x9-3/4")
Net Weight Berat Bersih 净重	1.5 - 1.8kg (3.2 - 3.9lbs)
Work Amount (approx.) Jumlah Kerja 工作量	275 pcs with BL1850B High Tensile Bolt M16

* All list price shown are for reference only (exclude SST).

* Semua harga yang ditunjukkan adalah untuk rujukan sahaja (tidak termasuk SST). 所有显示的建议零售价仅供参考 (不包括SST)。

Cordless Targeted Joints

LED Flashlight Lampu Saku LED LED 手电筒

Vacuum Cleaner Pembersih Vakuum 吸尘器

Drilling / Fastening Ganda / Pengait 钻孔 / 紧固

Impact Drilling / Demolition Ganda / Pembongkaran 冲击钻孔 / 拆除

Cutting Pemotong 切割

Grinding / Sanding Pengkilan / Poles 研磨 / 砂磨

Sanding / Grinding 砂磨 / 研磨

Planing / Routing Pengkilan / Tangkapan 刨削 / 截割

Others Lain-lain 其他

Outdoor Power Equipment Alatan Kuat Luar 户外动力设备



18V

LXT

Li-ion Ah 6.0 | 5.0 | 4.0 | 3.0 | 2.0 | 1.5

DTW251RME | DTW251RFE | DTW251Z 12.7mm (1/2") 448 RPM

Cordless Impact Wrench
Perengkuh Impak Tanpa Kord
充电式冲击套筒扳手



- High power, compact and lightweight 4-pole motor

Standard Equipment: Belt Clip

- RME: 1x Rapid Charger, 2x 4.0Ah Battery
- RFE: 1x Rapid Charger, 2x 3.0Ah Battery
- Z: Without Charger, Battery & Carrying Case



Fastening Capacities Keupayaan Pengancing 紧固能力	Standard Bolt: M10 - M16 (3/8" - 5/8") High Tensile Bolt: M10 - M14 (3/8" - 9/16")
Square Drive Skrü Persegi 方形螺柱	12.7mm (1/2")
No Load Speed (RPM) Kelajuan Tanpa Beban 回转数	0 - 2,100
Impacts Per Minute (IPM) Impak Per Minit 冲击数	0 - 3,200
Max Fastening Torque Tenaga Pemutaran Pengancing Maksimum 最大紧固扭力	230N-m (170ft.lbs.)
Nut-Busting Torque Tork Pembongkaran Maksimum 最大拆卸扭力	370N-m (270ft.lbs.)
Dimensions (L x W x H) Dimensi 体积	165x79x234mm (6-1/2"x3-1/8"x9-1/4")
Net Weight Berat Bersih 淨重	1.5 - 1.8kg (3.2 - 3.9lbs)
Work Amount (approx.) Jumlah Kerja 工作量	250 pcs with BL1850B Bolt M14

DTW181RFE | DTW181Z 12.7mm (1/2")

Cordless Impact Wrench
Perengkuh Impak Tanpa Kord
充电式冲击套筒扳手



- Ideal for working in tight spaces

Standard Equipment: Belt Clip

- RFE: 1x Rapid Charger, 2x 3.0Ah Battery
- Z: Without Charger, Battery & Carrying Case



Fastening Capacities Keupayaan Pengancing 紧固能力	Standard Bolt: M8 - M16 (5/16" - 5/8") High Strength Bolt: M6 - M12 (1/4" - 1/2")
Square Drive Skrü Persegi 方形螺柱	12.7 mm (1/2")
No Load Speed (RPM) Kelajuan Tanpa Beban 回转数	Hard: 0 - 2,400 Soft: 0 - 1,300
Impacts Per Minute (IPM) Impak Per Minit 冲击数	Hard: 0 - 3,600 Soft: 0 - 2,000
Max Fastening Torque Tenaga Pemutaran Pengancing Maksimum 最大紧固扭力	210N-m (155ft.lbs.)
Nut-Busting Torque Tork Pembongkaran Maksimum 最大拆卸扭力	330N-m (245ft.lbs.)
Dimensions (L x W x H) Dimensi 体积	151x79x235mm (5-15/16"x3-1/8"x9-1/4")
Net Weight Berat Bersih 淨重	1.2 - 1.5kg (2.7 - 3.4lbs.)

DTW190RFX2 | DTW190RFE | DTW190Z | DTW190ZX 12.7mm (1/2")

Cordless Impact Wrench
Perengkuh Impak Tanpa Kord
充电式冲击套筒扳手



- 190N-m (140ft.lbs.) of Max torque optimal for scaffold bulding

- RFX2 : 1x Rapid Charger, 2x 3.0Ah Battery, Shoulder Belt, Tool Catcher (197940-2)
- RFE : 1x Rapid Charger, 2x 3.0Ah Battery
- Z / ZX: Without Charger, Battery & Carrying Case



Fastening Capacities Keupayaan Pengancing 紧固能力	Standard Bolt: M8 - M16 (5/16" - 5/8") High Tensile Bolt: M8 - M12 (5/16" - 1/2")
Square Drive Skrü Persegi 方形螺柱	12.7mm (1/2")
No Load Speed (RPM) Kelajuan Tanpa Beban 回转数	0 - 2,300
Impacts Per Minute (IPM) Impak Per Minit 冲击数	0 - 3,000
Max Fastening Torque Tenaga Pemutaran Pengancing Maksimum 最大紧固扭力	190N-m (140ft.lbs.)
Nut-Busting Torque Tork Pembongkaran Maksimum 最大拆卸扭力	320N-m (235ft.lbs.)
Overall Length Dimensi 体积	176mm (6-15/16")
Net Weight Berat Bersih 淨重	1.4 - 1.8kg (3.2 - 3.9lbs)

DTW180Z 9.5mm (3/8")

Cordless Impact Wrench
Perengkuh Impak Tanpa Kord
充电式冲击套筒扳手



- Ideal for working in tight spaces

Standard Equipment: Belt Clip

- Z: Without Charger & Battery



Fastening Capacities Keupayaan Pengancing 紧固能力	Standard Bolt: M8 - M16 (5/16" - 5/8") High Tensile Bolt: M6 - M12 (1/4" - 1/2")
Square Drive Skrü Persegi 方形螺柱	9.5 mm (3/8")
No Load Speed (RPM) Kelajuan Tanpa Beban 回转数	Hard: 0 - 2,400 Soft: 0 - 1,300
Impacts Per Minute (IPM) Impak Per Minit 冲击数	Hard: 0 - 3,600 Soft: 0 - 2,000
Max Fastening Torque Tenaga Pemutaran Pengancing Maksimum 最大紧固扭力	180N-m (130ft.lbs.)
Nut-Busting Torque Tork Pembongkaran Maksimum 最大拆卸扭力	310N-m (228ft.lbs.)
Dimensions (L x W x H) Dimensi 体积	144x79x235mm (5-5/8"x3-1/8"x9-1/4")
Net Weight Berat Bersih 淨重	1.2 - 1.5kg (2.7 - 3.4lbs.)

Model No. 型号	Square Drive Skrü Pemacu Persegi 方形传动螺柱	No Load Speed (rpm) Kelajuan Tanpa Beban 回转数	Impacts Per Minute (IPM) Impak Per Minit 冲击数	Max. Fastening Torque (N.m) Tenaga Pemutaran Pengancing Maksimum 最大紧固扭力	Nut-Busting Torque (N.m) Tork Pembongkaran Maksimum 最大拆卸扭力	Overall Length (mm) Panjang Keseluruhan 总长度	Net Weight Berat Bersih 淨重	BL MOTOR	XPT
Cordless Impact Wrench									
DTW1001	19mm (3/4")	0-1,800/ 0-1,000/ 0-900	0 - 2,200 / 0 - 2,000 / 0 - 1,800	1,050 (780ft.lbs.)	1,700 (1,250ft.lbs.)	229	3.4kg (7.5lbs)	●	●
DTW1002	12.7mm (1/2")	0-1,800/ 0-1,000/ 0-900	0 - 2,200 / 0 - 2,000 / 0 - 1,800	1,000 (740ft.lbs.)	1,600 (1,180ft.lbs.)	229	3.3kg (7.3lbs)	●	●
DTW800	11.2mm (7/16") Hex.	0-1,800/ 0-1,000/ 0-900	0 - 2,200 / 0 - 2,000 / 0 - 1,800	800 (590ft.lbs.)	-	229	3.4kg (8.2lbs)	●	●
DTW700 / DTW701	12.7mm (1/2")	0-2,200/ 0-1,900/ 0-1,200/ 0-500	0-2,700/ 0-2,400/ 0-1,700/ 0-1,000	700 (520ft.lbs.)	1,000 (740ft.lbs.)	170	2.3kg (5.1lbs)	●	●
DTW450	12.7mm (1/2")	1,600	2,200	440 (325ft.lbs.)	730 (545ft.lbs.)	266	3.1kg (7.6lbs)	●	●
DTW300 / DTW301	12.7mm (1/2")	0-3,200/ 0-2,600/ 0-1,800/ 0-1,000	0-4,000/ 0-3,400/ 0-2,600/ 0-1,800	330 (240ft.lbs.)	580 (430ft.lbs.)	144	1.5kg (3.4lbs)	●	●
DTW302	9.5mm (3/8")	0-3,200/ 0-2,600/ 0-1,800/ 0-1,000	0-4,000/ 0-3,400/ 0-2,600/ 0-1,800	300 (220ft.lbs.)	500 (370ft.lbs.)	138	1.4kg (3.1lbs)	●	●
DTW285	12.7mm (1/2")	0-2,800/ 0-2,100/ 1,600	0 - 3,500 / 0 - 2,600 / 0 - 1,800	280 (210ft.lbs.)	500 (370ft.lbs.)	147	1.5kg (3.2lbs)	●	●
DTW251	12.7mm (1/2")	0-2,100	0 - 3,200	230 (170ft.lbs.)	370 (270ft.lbs.)	165	1.5kg (3.2lbs)	●	●
DTW181	12.7mm (1/2")	0-2,400/ 0-1,300	0 - 3,600/ 0-2,000	210 (155ft.lbs.)	330 (245ft.lbs.)	151	1.2kg (2.7lbs)	●	●
DTW180	9.5mm (3/8")	0-2,400/ 0-1,300	0 - 3,600/ 0-2,000	180 (130ft.lbs.)	320 (235ft.lbs.)	144	1.2kg (2.7lbs)	●	●
DTW190	12.7mm (1/2")	0-2,300	0 - 3,000	190 (140ft.lbs.)	310 (228ft.lbs.)	176	1.4kg (3.2lbs)	●	●

* All list price shown are for reference only (exclude SST).

* Semua harga yang ditunjukkan adalah untuk rujukan sahaja (tidak termasuk SST). 所有显示的建议零售价仅供参考 (不包括SST)。

Cordless Target Kord 无绳式
LED Flashlight Lampu Suluh LED LED 手电筒
Vacuum Cleaner Pembersih Vakuum 吸尘器
Drilling / Fastening Druai / Pemboleh 钻孔 / 紧固
Impact Drilling / Demolition Druai / Pemboleh 冲击钻孔 / 拆除加工
Cutting Pemotong 切割
Grinding / Sanding Pengisar / Poles 研磨 / 打磨
Sawing Cergas 电锯
Planing / Routing Pengisar / Tangkap 刨削 / 雕刻
Others Lain-lain 其他
Outdoor Power Equipment Alatan Kerja Luar 户外工具





Li-ion Ah 6.0 5.0 4.0 3.0 2.0 1.5

DWR180Z 9.5mm (3/8")

Cordless Ratchet Wrench
Perengkuh Ratchet Tanpa Kord
充电式棘轮扳手



- Supplied with two socket adapters for compatibility with a variety of sockets

Standard Equipment: Socket Adapter

• Z: Without Charger & Battery



Fastening Capacities Keupayaan Pengancing 紧固能力	Standard Bolt: M5 - M12 (3/16 - 1/2") High Strength Bolt: M5 - M10 (3/16 - 3/8") 9.5mm (3/8") 6.35mm (1/4")
Square Drive Kepala Segi Empat 方形头	
No Load Speed (RPM) Kelajuan Tanpa Beban 回转数	0 - 800
Max Fastening Torque Tenaga Pemutaran Pengancing Maksimum 最大紧固扭力	47.5N-m (420in.lbs.)
Flats Width Lebar Flat 单位宽度	13mm (1/2")
Angle Head Size Saiz Kepala Sudut 角头尺寸	Diameter: 31mm (1-7/32") Height: 25.5mm (1")
Dimensions (L x W x H) Dimensi 体积	369x79x87mm (14-1/2x3-1/8x3-7/16")
Net Weight Berat Bersih 净重	1.2 - 1.6kg (2.6 - 3.5lbs.)

DTL063Z 9.5mm (3/8")

Cordless Angle Impact Wrench
Perengkuh Impak Sudut Tanpa Kord
充电式角冲击套筒扳手



- Compact angle head for easy access to bolts in tight places

Standard Equipment: Belt Clip

• Z: Without Charger & Battery



Fastening Capacities Keupayaan Pengancing 紧固能力	Standard Bolt: M4 - M12 (5/32" - 1/2") High Tensile Bolt: M4 - M8 (5/32" - 5/16") 9.5mm (3/8")
Square Drive Skrü Persegi 方形螺杆	
No Load Speed (RPM) Kelajuan Tanpa Beban 回转数	0 - 2,000
Impacts Per Minute (IPM) Impak Per Minit 冲击数	0 - 3,000
Max Fastening Torque Tenaga Pemutaran Pengancing Maksimum 最大紧固扭力	60N-m (N/A ft.lbs.)
Dimensions (L x W x H) Dimensi 体积	387x78x116mm (15-1/4"x3-1/16"x4-9/16")
Net Weight Berat Bersih 净重	1.4 - 2.0kg (3.1 - 4.3lbs)

DHR242RTE | DHR242RME | DHR242RFE | DHR242Z 24mm (15/16")

Cordless Combination Hammer
Tukul Kombinasi Tanpa Kord
充电式冲击电钻电锤



- 3-Mode operation; rotation only, hammering with rotation and hammering only

Standard Equipment: Depth Gauge, Side Grip

- RTE: 1x Rapid Charger, 2x 5.0Ah Battery
- RME: 1x Rapid Charger, 2x 4.0Ah Battery
- RFE: 1x Rapid Charger, 2x 3.0Ah Battery
- Z: Without Charger, Battery & Carrying Case



Impact Energy Kekuatan Impak 单次最大锤击力	2J
Capacity Kapasiti 能力	Concrete: 24mm (15/16") Steel: 13mm (1/2") Wood: 27mm (1-1/16")
Impacts Per Minute (IPM) Impak Per Minit 冲击数	0 - 4,700
No Load Speed (RPM) Kelajuan Tanpa Beban 回转数	0 - 950
Dimensions (L x W x H) Dimensi 体积	328x85x213mm (12-7/8"x3-3/8"x8-3/8")
Net Weight Berat Bersih 净重	3.1 - 3.8kg (6.7 - 8.4lbs)
Work Amount (approx.) Jumlah Kerja 工作量	60 holes with BL1850B Masonry Drill ø10.5mm Concrete Depth 60mm

ACCESSORIES (Optional)

DX01 Dust Extraction System Set
Part No. 195896-3

DHR241RFE | DHR241Z 20mm (13/16")

441 mm

Cordless Combination Hammer
Tukul Kombinasi Tanpa Kord
充电式冲击电钻电锤



- 3-Mode operation; rotation only, hammering with rotation and hammering only

Standard Equipment: Depth Gauge, Side Grip

- RFE: 1x Rapid Charger, 2x 3.0Ah Battery
- Z: Without Charger, Battery & Carrying Case



Impact Energy Kekuatan Impak 单次最大锤击力	1.9J
Capacity Kapasiti 能力	Concrete: 20mm (13/16") Steel: 13mm (1/2") Wood: 26mm (1")
Impacts Per Minute (IPM) Impak Per Minit 冲击数	0 - 4,000
No Load Speed (RPM) Kelajuan Tanpa Beban 回转数	0 - 1,100
Dimensions (L x W x H) Dimensi 体积	417x84x219mm (16-3/8"x3-5/16"x8-5/8")
Net Weight Berat Bersih 净重	3.2 - 4.0kg (7.1 - 8.8lbs)
Work Amount (approx.) Jumlah Kerja 工作量	133 holes with BL1850B Masonry drill ø16.5mm Concrete Depth 40mm

DHR202RME | DHR202RFE | DHR202Z 20mm (13/16")

441 mm

Cordless Combination Hammer
Tukul Kombinasi Tanpa Kord
充电式冲击电钻电锤

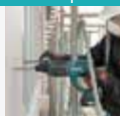

- 3-Mode operation; rotation only, hammering with rotation and hammering only

Standard Equipment: Depth Gauge, Side Grip

- RME: 1x Rapid Charger, 2x 4.0Ah Battery
- RFE: 1x Rapid Charger, 2x 3.0Ah Battery
- Z: Without Charger, Battery & Carrying Case



Capacity Kapasiti 能力	Concrete: 20mm (13/16") Steel: 13mm (1/2") Wood: 26mm (1")
Impacts Per Minute (IPM) Impak Per Minit 冲击数	0 - 4,000
No Load Speed (RPM) Kelajuan Tanpa Beban 回转数	0 - 1,100
Dimensions (L x W x H) Dimensi 体积	358x84x259mm (14-1/8"x3-5/16"x10-1/4")
Net Weight Berat Bersih 净重	3.2 - 4.0kg (7.1 - 8.8lbs)
Work Amount (approx.) Jumlah Kerja 工作量	130 holes with BL1850B Masonry drill ø6.5mm Concrete Depth 60mm

* All list price shown are for reference only (exclude SST).

* Semua harga yang ditunjukkan adalah untuk rujukan sahaja (tidak termasuk SST). 所有显示的建议零售价仅供参考 (不包括SST)。

Cordless
Target: 无线工具

LED Flashlight
Lampu Suluh LED
LED手电筒

Vacuum Cleaner
Pembersih Vakuum
吸尘器

Drilling / Fastening
Gantut / Pengangut
钻孔 / 紧固

Impact Drilling / Demolition
Gantut / Pembongkaran
冲击钻孔 / 拆毁

Cutting
Pemotong
切割

Grinding / Sanding
Pengamiran / Pemoles
研磨 / 砂磨

Sawing
Gergaji
锯切

Planing / Routing
Pengayutan / Tunggau
刨削 / 磨削

Others
Lain-lain
其他

Outdoor Power Equipment
Alatan Kuat Luar
户外动力工具

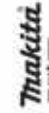

18V

LXT

Li-ion Ah 6.0 | 5.0 | 4.0 | 3.0 | 2.0 | 1.5

DHR182ZWJ 18mm (11/16")**Cordless Combination Hammer**Tukul Kombinasi Tanpa Kord
充电式冲击电钻电锤

3 modes

- Auto-start Wireless System (AWS) connects to vacuum cleaner with Bluetooth

Standard Equipment: Side Grip, Depth Gauge

- ZWJ: Without Charger, Battery, Come with 1x Dust Extraction System Set, 1x Makpac Connector Box

Come with
DX05 Dust Extraction System Set
Part No. 199658-1

BL MOTOR XPT AVT AWS

Impact Energy Kekuatan Impak 单次最大锤击力	EPTA-Procedure 05/2009: 1.7J Our experimental conditions: 1.6J
Capacity Kapasiti 能力	Concrete: 18mm (11/16") Core Bit: 35mm (1-3/8") Diamond Core Bit (Dry Type): 32mm (1-1/4") Steel: 13mm (1/2") Wood: 24mm (15/16")
Impacts Per Minute (IPM) Impak Per Minit 冲击数	0 - 5,000
No Load Speed (RPM) Kelajuan Tanpa Beban 回转数	0 - 1,350
Max Output Keluaran Maksima 最大输出	450W
Dimensions (L x W x H) Dimensi 体积	301x82x285mm (11-7/8"x3-1/4"x11-1/4")
Net Weight Berat Bersih 淨重	2.4 - 3.2kg (5.3 - 7.0lbs.)
Work Amount (approx.) Jumlah Kerja 工作量	140 holes with BL1850B Masonry Drill Ø6.5mm Concrete 40N/ mm2 Depth 60mm

DHR171RTE | DHR171RFE | DHR171Z 17mm (11/16")**Cordless Rotary Hammer**Tukul Putar Tanpa Kord
充电式电锤

2 modes

- 2-Mode operation; rotation only, or hammering with rotation only

Standard Equipment: Side Grip, Depth Gauge

- RTE: 1x Rapid Charger, 2x 5.0Ah Battery
- RFE: 1x Rapid Charger, 2x 3.0Ah Battery
- Z: Without Charger, Battery & Carrying Case

BL MOTOR XPT AVT AWS *Not applicable for Z model



Impact Energy Kekuatan Impak 单次最大锤击力	EPTA-Procedure 05/2009: 1.2J Our experimental conditions: 1.1J
Capacity Kapasiti 能力	Concrete: 17mm (11/16") Steel: 10mm (3/8") Wood: 13mm (1/2")
Impacts Per Minute (IPM) Impak Per Minit 冲击数	0 - 4,800
No Load Speed (RPM) Kelajuan Tanpa Beban 回转数	0 - 680
Dimensions (L x W x H) Dimensi 体积	273x86x211mm (10-3/4"x3-3/8"x8-5/16")
Net Weight Berat Bersih 淨重	2.1 - 2.8kg (4.6 - 6.2lbs)
Work Amount (approx.) Jumlah Kerja 工作量	220 holes with BL1850B Masonry Drill Ø6mm Concrete 40N/ mm2 Depth 40mm

DHR165RME | DHR165RFE | DHR165Z 16mm (5/8")

430 mm

Cordless Rotary HammerTukul Putar Tanpa Kord
充电式电锤

2 modes

- 2-Mode operation; rotation only, or hammering with rotation only

Standard Equipment: Depth Gauge, Side Grip

- RME: 1x Rapid Charger, 2x 4.0Ah Battery
- RFE: 1x Rapid Charger, 2x 3.0Ah Battery
- Z: Without Charger, Battery & Carrying Case

BL MOTOR XPT AVT AWS *Not applicable for Z model



Impact Energy Kekuatan Impak 单次最大锤击力	1.3J
Capacity Kapasiti 能力	Concrete: 16mm (5/8") Steel: 13mm (1/2") Wood: 24mm (15/16")
Impacts Per Minute (IPM) Impak Per Minit 冲击数	0 - 5,300
No Load Speed (RPM) Kelajuan Tanpa Beban 回转数	0-1,600
Dimensions (L x W x H) Dimensi 体积	297x79x253mm (11-3/4"x3-1/8"x10")
Net Weight Berat Bersih 淨重	2.3 - 3.0kg (5.0 - 6.6lbs)
Work Amount (approx.) Jumlah Kerja 工作量	225 holes with BL1850B Masonry drill Ø6.5mm Concrete Depth 30mm

DHK180Z**Cordless Power Scraper**Pengikis Kuasa Tanpa Kord
充电式铲平机

- High power & low vibration

Standard Equipment: Hook

- Z: Without Charger & Battery

BL MOTOR XPT AVT AWS



Impact Energy Kekuatan Impak 单次最大锤击力	EPTA-Procedure 05/2009: 3.1J Our experimental conditions: 3.9J
Impact Per Minute (IPM) Impak Per Minit 冲击数	0 - 3,200
Dimensions (L x W x H) Dimensi 体积	368x99x211mm (14-1/2"x3-7/8"x8-5/16")
Net Weight Berat Bersih 淨重	3.3 - 3.6 kg (7.3 - 7.9 lbs.)
Continuous Usage Time (approx.) Masa Penggunaan Berterusan 连续使用时间	17min with BL1850B

DUT130RFE | DUT130Z | DUT131Z**Cordless Mixer**Pengadun Tanpa Kord
充电式搅拌机

- Battery cover prevents concrete to be scattered on the battery

Standard Equipment:
DUT130: Mixing Blade, Shaft, Shaft Holder, Side Grip,
Front Cover, Wrenches, Tool Bag

DUT131: Front Cover, Side Grip, Chuck Key, Tool Bag

- RFE: 1x Rapid Charger, 2x 3.0Ah Battery
- Z: Without Charger & Battery

BL MOTOR XPT AVT AWS

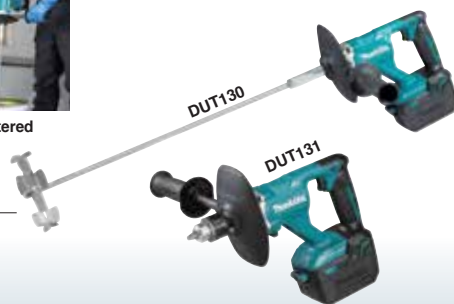

Chuck Capacity Kapasiti Chuck 夹头能力	1.5 - 13mm (1/16 - 1/2") DUT131
Blade Diameter Diameter Bilah 锯片直径	165mm (6-1/2") DUT130
Shank size of tool holder portion Batang Saiz 柄部尺寸	M12 or M14 DUT130
No Load Speed (RPM) Kelajuan Tanpa Beban 回转数	High: 0 - 1,300 Low: 0 - 350
Dimensions (L x W x H) Dimensi 体积	916x89x231mm DUT130 (36"x3-1/2"x9-1/8") 307x89x231mm DUT131 (12-1/8"x3-1/2"x9-1/8")
Net Weight Berat Bersih 淨重	2.5 - 2.8 kg (5.6 - 6.3 lbs.) DUT130 2.7 - 3.0kg (5.8 - 6.6lbs.) DUT131
Continuous Usage Time (approx.) Masa Penggunaan Berterusan 连续使用时间	25min with BL1850B One Liquid Paint 4L - High Speed

* All list price shown are for reference only (exclude SST).

* Semua harga yang ditunjukkan adalah untuk rujukan sahaja (tidak termasuk SST). 所有显示的建议零售价仅供参考 (不包括SST)。

Cordless
Tanpa Kord 无线式LED Flashlight
Lampu Suluh LED
LED 照明灯Vacuum Cleaner
Pembersih Vakuam
吸尘器Drilling / Fastening
Druai / Pasang
钻孔 / 紧固Impact Drilling / Demolition
Druai / Penanggal
起工钻孔 / 拆除加工Cutting
Pemotong
切割Grinding / Sanding
Pengisar / Pasah
打磨 / 砂磨Sawing
Gergaji
锯切Planing / Routing
Pengaram / Tampat
刨削 / 雕刻Others
Lain-lain
其他Outdoor Power Equipment
Alatan Kerja Luar
园具-户外Makita
MAKITA



Li-ion Ah 6.0 5.0 4.0 3.0 2.0 1.5

DCS553Z 150mm (5-7/8")

Cordless Metal Cutter
Pemotong Logam Tanpa Kord
充电式金属切割机



- Built-in dust collection box for cleaner work environment

Standard Equipment: TCT Saw Blade, Hex Wrench, Safety Goggles, Guide Rule

- Z: Without Charger & Battery



Max Output Keluaran Maksima 最大输出	600W
Blade Diameter Diameter Bilah 锯片直径	150mm (5-7/8")
Hole Diameter Diameter Lubang 孔直径	20mm (13/16")
Max Cutting Capacity Kapasiti Pemotongan Maksimum 最大切割能力	90°: 57.5mm (2-1/4")
No Load Speed (RPM) Kelajuan Tanpa Beban 回转数	4,200
Dimensions (L x W x H) Dimensi 体积	267x186x250mm (10-1/2"x7-3/8"x9-7/8")
Net Weight Berat Bersih 净重	2.8 - 3.1kg (6.1 - 6.8lbs.)
Work Amount (approx.) Jumlah Kerja 工作量	125 cuts with BL1850B Saw Blade - Carbon Steel Pipe Ø 34mm, Thickness 3.2mm

DCS552Z 136mm (5-3/8")

430 Wh

Cordless Metal Cutter
Pemotong Logam Tanpa Kord
充电式金属切割机



- Built-in dust collection box for cleaner work environment

Standard Equipment: TCT Saw Blade (B-07319), Hex Wrench, Safety Goggles

- Z: Without Charger & Battery



Max Output Keluaran Maksima 最大输出	370W
Blade Diameter Diameter Bilah 锯片直径	136mm (5-3/8")
Hole Diameter Diameter Lubang 孔直径	20mm (13/16")
Max Cutting Capacity Kapasiti Pemotongan Maksimum 最大切割能力	90°: 50.5mm (2")
No Load Speed (RPM) Kelajuan Tanpa Beban 回转数	3,600
Dimensions (L x W x H) Dimensi 体积	348x196x203mm (13-3/4"x7-3/4"x8")
Net Weight Berat Bersih 净重	2.4 - 2.7kg (5.3 - 6.0lbs.)
Work Amount (approx.) Jumlah Kerja 工作量	125 cuts with BL1850B Saw Blade - Carbon Steel Pipe Ø 34mm, Thickness 3.2mm

DCS551RFJ | **DCS551Z** 150mm (5-7/8")

Cordless Metal Cutter
Pemotong Logam Tanpa Kord
充电式金属切割机



- Cuts 51mm (2") conduit in a single pass

Standard Equipment: TCT Saw Blade (B-46296), Hex Wrench, Safety Goggles

- RFJ: 1x Rapid Charger, 2x 3.0Ah Battery, 1x Makpac Connector Box
- Z: Without Charger, Battery & Carrying Case



Blade Diameter Diameter Bilah 锯片直径	150mm (5-7/8")
Max Cutting Capacity Kapasiti Pemotongan Maksimum 最大切割能力	90°: 57.5mm (2-1/4")
No Load Speed (RPM) Kelajuan Tanpa Beban 回转数	3,900
Dimensions (L x W x H) Dimensi 体积	332x158x231mm (13-1/8"x6-1/4"x9-1/8")
Net weight Berat Bersih 净重	2.5 - 2.8kg (5.5 - 6.2lbs)
Work Amount (approx.) Jumlah Kerja 工作量	210 pcs with BL1850B Saw Blade - Wire Tube Ø 38.1mm, Wall Thickness 1.4mm

DCS550RFE | **DCS550Z** 136mm (5-3/8")

430 Wh

Cordless Metal Cutter
Pemotong Logam Tanpa Kord
充电式金属切割机



- Carbide-tipped 30T blade for cutting a wide range of materials

Standard Equipment: TCT Saw Blade (B-07319), Hex Wrench, Safety Goggles

- RFE: 1x Rapid Charger, 2x 3.0Ah Battery
- Z: Without Charger, Battery & Carrying Case



Blade Diameter Diameter Bilah 锯片直径	136mm (5-3/8")
Max Cutting Capacity Kapasiti Pemotongan Maksimum 最大切割能力	90°: 51mm (2")
No Load Speed (RPM) Kelajuan Tanpa Beban 回转数	3,600
Dimensions (L x W x H) Dimensi 体积	348x180x201mm (13-3/4"x7-1/8"x7-7/8")
Net weight Berat Bersih 净重	2.2 - 2.6kg (4.9 - 5.7lbs)
Work Amount (approx.) Jumlah Kerja 工作量	216 pcs with BL1850B Saw Blade - Wire Tube Ø 38.1mm, Wall Thickness 1.4mm

DJS130RFE | **DJS130Z** 1.3mm

440 Wh

Cordless Metal Shear
Pemotong Logam Tanpa Kord
充电式电剪



- 360° swivel shear head for increased cutting convenience

Standard Equipment: Hex Wrench

- RFE: 1x Rapid Charger, 2x 3.0Ah Battery
- Z: Without Charger, Battery & Carrying Case

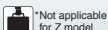

Capacity Kapasiti 能力	Steel up to 400 N/mm ² : 1.3mm Steel up to 600 N/mm ² : 1.0mm 2,800
No Load Speed (RPM) Kelajuan Tanpa Beban 回转数	
Dimensions (L x W x H) Dimensi 体积	350x80x193mm (13-3/4"x3-1/8"x7-5/8")
Net weight Berat Bersih 净重	2.3 - 2.6kg (5.0 - 5.8lbs)
Work Amount (approx.) Jumlah Kerja 工作量	200 pcs with BL1850B Cutting (SPCC Sheet 1.0 x 600mm)

* All list price shown are for reference only (exclude SST).

* Semua harga yang ditunjukkan adalah untuk rujukan sahaja (tidak termasuk SST). 所有显示的建议零售价仅供参考 (不包括SST)。

Cordless
Tanpa Kord / Tanpa Kabel

LED Flashlight
Lampu Suli LED / LED 闪光灯

Vacuum Cleaner
Pembersih Vakuum / 吸尘器

Drilling / Fastening
Ganuli / Pasak / 钻孔 / 紧固

Impact Drilling / Demolition
Ganuli / Pasak / 冲击钻孔 / 拆除

Cutting
Pemotong / 切割

Grinding / Sanding
Pengkilan / Pasah / 研磨 / 砂磨

Sawing
Gajuk / 锯切

Planing / Routing
Pengkilan / Tangam / 刨削 / 铣削

Others
Lain-lain / 其他

Outdoor Power Equipment
Alatan Kerja Luar / 户外动力工具

18V

LXT

Li-ion Ah 6.0 5.0 4.0 3.0 2.0 1.5

DJS161Z 1.6mm

430 

Cordless Straight Shear

Pemotong Logam Lurus
Tanpa Kord
充电式电剪压穿式

- High cutting capacity: cuts up to 1.6mm thick mild steel sheet



Standard Equipment: Hex Wrench, Thickness Gauge

- Z: Without Charger & Battery

Capacity

Kapasiti 能力

Steel up to 400 N/mm²: 1.6mm
Steel up to 600 N/mm²: 1.2mm
Aluminum up to 200 N/mm²: 2.5mm

Strokes Per Minute (SPM)

Kelajuan Strok 冲程速度

4,300

Dimensions (L x W x H)

Dimensi 体积

362x78x118mm
(14-1/4"x3-1/16"x4-5/8")

Net weight

Berat Bersih 淨重

1.8 - 2.2kg (4.1 - 4.8lbs)

Work Amount (approx.)

Jumlah Kerja 工作量

95 pcs with BL1850B
Cutting (Thin Metal Plate 1.2mm)

DJS101Z 1.0mm

430 

Cordless Metal Shear

Pemotong Logam Tanpa Kord
充电式电剪

- Easy curve cutting with a smooth edge



Standard Equipment: Hex Wrench

- Z: Without Charger & Battery

Capacity

Kapasiti 能力

Steel up to 400 N/mm²: 1.0mm
Steel up to 600 N/mm²: 0.7mm
Aluminum up to 200 N/mm²: 2.5mm

Strokes Per Minute (SPM)

Kelajuan Strok 冲程速度

4,300

Dimensions (L x W x H)

Dimensi 体积

364x78x118mm
(14-3/8"x3-1/16"x4-5/8")

Net weight

Berat Bersih 淨重

1.8 - 2.2kg (4.0 - 4.7lbs)

Work Amount (approx.)

Jumlah Kerja 工作量

150 pcs with BL1850B
Cutting
(Steel sheet SUS430 600x1.0mm)

DJN161Z 1.6mm (16Ga)

430 

Cordless Nibbler

Tukul Pemutar Skru Bergerudi
Tanpa Kord
充电式电冲剪

- Ideal for cutting roofing sheet metal at thicknesses up to 16 gauge



Standard Equipment: Hex Wrench, Wrench, Punch, Die

- Z: Without Charger & Battery

Capacity

Kapasiti 能力

Steel up to 400 N/mm²: 1.6mm
Steel up to 600 N/mm²: 1.2mm
Aluminum up to 200 N/mm²: 2.5mm

Min. Cutting Radius

Radius Pemotongan Minimum 最小切割半径

Inside edge: 45mm (1-3/4")
Outside edge: 50mm (2")

Strokes Per Minute (SPM)

Kelajuan Strok 冲程速度

1,900

Dimensions (L x W x H)

Dimensi 体积

313x78x189mm
(12-5/8"x3-1/8"x7-7/16")

Net weight

Berat Bersih 淨重

1.9 - 2.3kg (4.3 - 5.0lbs)

Work Amount (approx.)

Jumlah Kerja 工作量

30m with BL1850B
Cutting (Steel Plate 1mm)

DRV250Z | DRV150Z

Cordless Rivet Gun

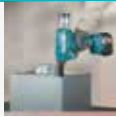
Penembak Rivet Tanpa Kord
充电式打钉枪

- Compact center height for increased maneuverability against a wall



Standard Equipment: Grease (191D57-7), Accessory Set, Belt Clip

- Z: Without Charger & Battery



Max Pulling Force

Kekuatan Tarikan Maksimum 拉钉力量

20kN DRV250
10kN DRV150

Length of Stroke

Panjang Strok 冲程长度

30mm (1-3/16") DRV250
25mm (1") DRV150

Dimensions (L x W x H)

Dimensi 体积

320x79x287mm DRV250
(12-5/8"x3-1/8"x11-1/4")310x80x287mm DRV150
(12-1/4"x3-1/8"x11-1/4")

Net Weight

Berat Bersih 淨重

2.1 - 2.4kg (4.6 - 5.2lbs.) DRV250
1.9 - 2.2kg (4.3 - 5.0lbs.) DRV150

Work Amount (approx.)

Jumlah Kerja 工作量

2,000 rivets with BL1850B DRV250
2,300 rivets with BL1850B DRV150
Mandrel diameter: Ø4.8mm

DPP200ZK

440 

Cordless Hole Puncher

Penebuk Lubang Tanpa Kord
充电式油压冲孔机

*Not compatible with 2.0Ah, 1.5Ah batteries

- Punches up to 20 mm Holes through Steel Plate up to 8 mm thick

Standard Equipment: Punch, Dice, Hex Wrench,
Spanner, Bar for fastening nuts, Grip, Oil

- ZK: With Carrying Case, Without Charger & Battery



Capacity

Keupayaan 能力

Steel: 20mm (13/16")
Stainless Steel: 20mm (13/16")
40mm (1-9/16")

Max Throat Depth

Kedalaman Maksimum 最大深度

417x127x315mm

Dimensi 体积

(16-3/8"x5"x12-3/8")

Net Weight

Berat Bersih 淨重

10.5kg (23.2lbs.)

Work Amount (approx.)

Jumlah Kerja 工作量

110 holes with BL1830B
on General steel for Ø20 mm with
6mm Thickness

* All list price shown are for reference only (exclude SST).

* Semua harga yang ditunjukkan adalah untuk rujukan sahaja (tidak termasuk SST). 所有显示的建议零售价仅供参考 (不包括SST)。

Cordless
Target Kord 无绳式LED Flashlight
Lampu Suluh LED
LED 照明灯Vacuum Cleaner
Pembersih Vakuüm
吸尘器Drilling / Fastening
Ganda / Pengikat
钻孔 / 紧固Impact Drilling / Demolition
Ganda / Perseksi
钻孔 / 拆除加工Cutting
Pemotong
切割Grinding / Sanding
Pengisar / Pasir
磨削 / 打磨Sawing
Ganda
切割Planing / Routing
Pengisar / Tangkai
刨削 / 雕刻Others
Lain-lain
其他Outdoor Power Equipment
Alatan Kerja Luar
园具-户外Makita
1915

18V

LXT

Li-ion Ah 6.0 5.0 4.0 3.0 2.0 1.5

DSC102 Cordless Threaded Rod Cutter

Work Amount with BL1850B (Mild steel M10)

1,330 rods (approx.)

Cutting Capacity M6 - M10 (W3/8")

Performs stable cutting even on the floor



LED job light

Rod Guide

There are two rod guide positions



◀ [1]
Size of threaded rod
W3/8, M10



◀ [2]
Size of threaded rod
M8, M6

Blade Cover
Can be used as a rod support

Accessories

Cutter Blade Set
Replacing the cutting dice



	Type		Cutting Capacities	Part No.
	inch screw	Mild steel •Stainless steel		
mm screw	Mild steel •Stainless steel	M6	199086-0	
	Mild steel •Stainless steel	M8	199084-4	
	Mild steel	M10	199082-8	

DSC102ZJ

Cordless Threaded Rod Cutter

Pemotong Batang Keluli Tanpa Kord
充电式螺纹杆切割机

- More Compact & High Productivity



Standard Equipment: Cutter Blade Set W3/8 (199080-2), Hex Socket Head Bolt, Blade Cover, Depth Gauge, Thumb Screw, Hex Wrench

- ZJ: With 1x Makpac Connector Box, Without Charger & Battery



Capacity Kapasiti 能力	Mild Steel: W3/8, M10, M8, M6 Stainless Steel: W3/8, M8, M6
Min. Cutting Length Panjang Pemotongan Minimum 最小切割长度	20mm (13/16")
Dimensions (L x W x H) Dimensi 体积	199x103x308mm (7-7/8"x4-1/16"x12-1/8")
Net Weight Berat Bersih 净重	2.8 - 3.2kg (6.2 - 7.0lbs.)
Work Amount (approx.) Jumlah Kerja 工作量	1330 rods with BL1850B (Mild steel M10)

DSC121ZK

Cordless Threaded Rod Cutter

Pemotong Batang Berulir Tanpa Kord
充电式螺纹杆切割机

- Power Cutting at High Speed



Standard Equipment: W3/8 Cutter Blade, Stand, Oil, Hex Wrench

- ZK: With 1x Makpac Connector Box, Without Charger & Battery



Capacity Kapasiti 能力	Steel: 8 - 12mm (5/16" - 1/2")
Cutting Speed (sec) Kelajuan Bilah 刀片速度	3.0
Dimensions (L x W x H) Dimensi 体积	212x323x260mm (8-3/8"x12-3/4"x10-1/4")
Net Weight Berat Bersih 净重	6.0kg (13.2lbs.)
Work Amount (approx.) Jumlah Kerja 工作量	420 rods with BL1850B (Mild steel M12)

DSC162Z DSC163ZK

Cordless Steel Rod Cutter

Pemotong Keluli Tanpa Kord
充电式钢筋切割机

- Spark free cutting of rebar and steel rod ideal for use in sensitive areas



Standard Equipment: Wrench, Hex Wrench, Oil supply

- Z: Without Charger & Battery
- ZK: With Carrying Case, Without Charger & Battery



Cutting Capacity Kapasiti Pemotongan 切割能力	Dia.: 3 - 16mm (1/8" - 5/8")
Cutting Speed (sec) Kelajuan Memotong 切割速度	4.0 DSC162 2.8 DSC163
Dimensions (L x W x H) Dimensi 体积	380x108x265mm DSC162 (15"x4-1/4"x10-3/8") 360x108x276mm DSC163 (14-1/8"x4-1/4"x10-7/8")
Net Weight Berat Bersih 净重	7.1kg (15.7lbs.) DSC162 6.9kg (15.2lbs.) DSC163
Work Amount (approx.) Jumlah Kerja 工作量	191 pcs with BL1850B DSC162 Cutting (Rebar ø16) 233 pcs with BL1850B DSC163 Cutting (Rebar ø16)

* All list price shown are for reference only (exclude SST).

* Semua harga yang ditunjukkan adalah untuk rujukan sahaja (tidak termasuk SST). 所有显示的建议零售价仅供参考 (不包括SST)。

Cordless
Target: Tanpa Kord

LED Flashlight
Lampu Suhu LED
LED 闪光灯

Vacuum Cleaner
Pembersih Vakuum
吸尘器

Drilling / Fastening
Gantuli / Pengikat
钻孔 / 紧固

Impact Drilling / Demolition
Gantuli / Pemusnah
冲击钻孔 / 拆毁施工

Cutting
Pemotong
切割

Grinding / Sanding
Pengkilan / Pemoles
研磨 / 砂磨

Sawing
Gergaji
锯切

Planing / Routing
Pengkilan / Tunggam
刨削 / 压花

Others
Lain-lain
其他

Outdoor Power Equipment
Alatan Kuat Luar
户外动力工具

Makita
MAKITA



Li-ion Ah 6.0 | 5.0 | 4.0 | 3.0 | 2.0 | 1.5

DSC191Z

440 mm

Cordless Steel Rod Cutter
Pemotong Keluli Tanpa Kord
充电式钢筋切割机



- Ideal for cutting steel bars laid in concrete slab

Standard Equipment: Wrench, Hex Wrench, Oil supply

- Z: Without Charger & Battery



Cutting Capacity Kapasiti Pemotongan 切割能力	Dia.: 3 - 20mm (1/8" - 3/4")
Cutting Speed (sec) Kelajuan Memotong 切割速度	6.5
Dimensions (L x W x H) Dimensi 体积	412x212x284mm (16-1/5"x8-3/8"x11-1/8")
Net Weight Berat Bersih 淨重	11.1 - 11.2kg (24.5 - 24.6lbs)
Work Amount (approx.) Jumlah Kerja 工作量	333 pcs with BL1850B Cutting (Rebar ø10)

DSC251ZK

Cordless Steel Rod Cutter
Pemotong Keluli Tanpa Kord
充电式钢筋切割机



- Ideal for edge cutting of threaded rods and rebars

Standard Equipment: Tipped Saw, Dust Bag, Side Grip, Hex Wrench

- ZK: With Carrying Case, Without Charger & Battery



Blade Diameter Diameter Bilah 锯片直径	110mm (4-5/16")
Cutting Capacity Kapasiti Pemotongan 切割能力	Dia.: 10 - 25mm (3/8" - 1")
No Load Speed (RPM) Kelajuan Tanpa Beban 回转数	2,200
Dimensions (L x W x H) Dimensi 体积	471x137x139mm (18-1/2"x5-3/8"x5-1/2")
Net Weight Berat Bersih 淨重	3.9 - 4.0kg (8.7 - 8.8lbs)
Work Amount (approx.) Jumlah Kerja 工作量	60 pcs with BL1850B Cutting Rebar SD345 490N/mm ² D25

DTR180
Cordless Rebar Tying Tool

Easy to load with tie wire reel



Work Amount with BL1850B (D10 x D10 Rebar)

5,300 times (approx.)

Tying Speed **0.95** second with (D10 x D10 Rebar)

1 Reel about 120 times (D10 x D10 Rebar)

Accessories Tie Wire Set (Ø0.8mm) 50pcs/ box Part No. 199137-9



Applicable Rebars: D10 x D10 - (D13 x 2) x (D13 x 2)

Tying Capacity (2 pcs of rebars)	Tying Capacity (3 pcs of rebars)		Tying Capacity (4 pcs of rebars)	
	D10 (#3)	D13 (#4)	D10 (#3) x D10 (#3)	D13 (#4) x D13 (#4)
D10 (#3)	✓	✓	✓	✓
D13 (#4)	✓	✓	✓	✓
D16 (#5)	✓	✓	✓	—

(# means perimeter length: cm)

DTR180ZJ

Cordless Rebar Tying Tool
Alat Pengikat Rebar Tanpa Kord
充电式钢筋捆绑机



- Continuous actuation mode for efficient continuous rebar tying

Standard Equipment: Hex Wrench, Hook

- ZJ: With 1x Makpac Connector Box, Without Charger & Battery



Tie Wire Wayar Pengikat 绑线	ø0.8mm
Applicable Rebars Keluli yang Sesuai 适用钢筋	D10 x D10 - (D13 x 2) x (D13 x 2)
Dimensions (L x W x H) Dimensi 体积	304x93x318mm (12"x3-2/3"x12-1/2")
Net Weight Berat Bersih 淨重	2.3 - 2.6kg (5.1 - 5.7lbs.)
Work Amount (approx.) Jumlah Kerja 工作量	5300 times with BL1850B Tying (D10 x D10 Rebar)



DTR180

VIDEO CLIP
Models and specs may vary by country

* All list price shown are for reference only (exclude SST).

* Semua harga yang ditunjukkan adalah untuk rujukan sahaja (tidak termasuk SST). 所有显示的建议零售价仅供参考 (不包括SST)。

Cordless Target Kord 无绳式
LED Flashlight Lampu Sulu LED LED 照明灯
Vacuum Cleaner Pemilauhi VAKUUM 吸尘器
Drilling / Fastening Druai / Pemasok 钻孔 / 紧固
Impact Drilling / Demolition Druai / Penembok 冲击钻孔 / 拆除加工
Cutting Pemotong 切割
Grinding / Sanding Pengisar / Pasok 打磨 / 砂磨
Sawing Gergaji 锯切
Planing / Routing Pengisar / Tangkai 刨削 / 锯架
Others Lain-lain 其他
Outdoor Power Equipment Alatan Kerja Luar 户外动力设备





Li-ion Ah 6.0 5.0 4.0 3.0 2.0 1.5

DPB180Z

430mm

Cordless Portable Band Saw
Gergaji Pita Tanpa Kord
充电式带锯机



- 6-Setting variable speed control dial enables user to match the speed to the application

Standard Equipment: Band Saw Blade, Hex Wrench

• Z: Without Charger & Battery



Capacity Kapasiti 能力	Round: 120mm (4-3/4") Rectangular workpiece w/o stand: 120x120mm (4-3/4"x4-3/4")
--------------------------------	--

Blade Speed Kelajuan Bilah 刀片速度	1.4-2.7m/s (275-530ft/min.)
---	-----------------------------

Dimensions (L x W x H) Dimensi 体积	523x231x313mm (20-5/8"x9-1/8"x12-3/8")
---	---

Net Weight Berat Bersih 淨重	6.8 - 7.1kg (14.9 - 15.7lbs)
--------------------------------------	------------------------------

Work Amount (approx.) Jumlah Kerja 工作量	200 pcs with BL1850B Cutting (Steel Wire Tube Ø38.1mm) (1.4mm Thickness)
--	--

DPB182Z

Cordless Portable Band Saw
Gergaji Pita Tanpa Kord
充电式带锯机



- Aluminum housing improves rigidity and prevents blade coming off

Standard Equipment: Band Saw Blade, Hex Wrench

• Z: Without Charger & Battery



DPB182

VIDEO CLIP
Models and specs may vary by country

Capacity Kapasiti 能力	Round: 64mm (2-1/2") Rectangular: 64x64mm (2-1/2"x2-1/2") 3.2m/s (630ft/min.)
--------------------------------	---

Blade Speed Kelajuan Bilah 刀片速度	3.2m/s (630ft/min.)
---	---------------------

Blade Size Saiz Bilah 锯片尺寸	Length: 835mm (32-7/8") Width: 13mm (1/2") Thickness: 0.5mm (0.02")
--------------------------------------	---

Dimensions (L x W x H) Dimensi 体积	477x197x229mm (18-3/4"x7-3/4"x9")
---	--------------------------------------

Net Weight Berat Bersih 淨重	3.8 - 4.1kg (8.3 - 9.0lbs.)
--------------------------------------	-----------------------------

Work Amount (approx.) Jumlah Kerja 工作量	210 pcs with BL1850B Cutting (Steel Wire Tube Ø38.1mm) (1.4mm Thickness)
--	--

DPB183Z

Cordless Portable Band Saw
Gergaji Pita Tanpa Kord
充电式带锯机



- Constant speed control minimizes the reduction in blade speed to provide stable cutting

Standard Equipment: Band Saw Blade, Hex Wrench

• Z: Without Charger & Battery



DPB183

VIDEO CLIP
Models and specs may vary by country

Capacity Keupayaan 能力	Round: 66mm (2-5/8") Square: 66 x 66mm (2-5/8 x 2-5/8") 0 - 3.2 m/s (0 - 630ft/min.)
---------------------------------	--

Blade Speed Kelajuan Bilah 锯片速度	0 - 3.2 m/s (0 - 630ft/min.)
---	------------------------------

Blade Size Saiz Bilah 锯片尺寸	Length: 835mm (32-7/8") Width: 13mm (1/2") Thickness: 0.5mm (0.02")
--------------------------------------	---

Dimensions (L x W x H) Dimensi 体积	392x174x242mm (15-1/2x6-7/8x9-1/2")
---	-------------------------------------

Net Weight Berat Bersih 淨重	3.6 - 3.9kg (7.9 - 8.6lbs.)
--------------------------------------	-----------------------------

Work Amount (approx.) Jumlah Kerja 工作量	250 pcs with BL1850B Cutting (Steel Wire Tube Ø38.1mm) (1.4mm Thickness)
--	--

DPB184Z

Cordless Portable Band Saw
Gergaji Pita Tanpa Kord
充电式带锯机



- Constant speed control minimizes the reduction in blade speed to provide stable cutting

Standard Equipment: Band Saw Blade, Hex Wrench

• Z: Without Charger & Battery



DPB184

VIDEO CLIP
Models and specs may vary by country

Capacity Keupayaan 能力	Round: 51mm (2") Square: 51 x 51mm (2 x 2") 0 - 3.2 m/s (0 - 630ft/min.)
---------------------------------	--

Blade Speed Kelajuan Bilah 锯片速度	0 - 3.2 m/s (0 - 630ft/min.)
---	------------------------------

Blade Size Saiz Bilah 锯片尺寸	Length: 730mm (28-3/4") Width: 13mm (1/2") Thickness: 0.5mm (0.02")
--------------------------------------	---

Dimensions (L x W x H) Dimensi 体积	373x162x223mm (14-3/4x6-3/8x8-3/4")
---	--

Net Weight Berat Bersih 淨重	3.3 - 3.6kg (7.3 - 7.9lbs.)
--------------------------------------	-----------------------------

Work Amount (approx.) Jumlah Kerja 工作量	400 pcs with BL1850B Cutting (Steel Wire Tube Ø25.4mm) (1.2mm Thickness)
--	--

DCC500Z

Cordless Dustless Cutter
Pemotong Tanpa Kord
充电式切割机



- Auto-start Wireless System (AWS) connects to compatible vacuum cleaners with Bluetooth

Standard Equipment: Dust Bag, Hex Wrench

• Z: Without Charger & Battery



ACCESSORIES (Optional)
Water Supply Cover Set A
Part No. 191M48-2

Blade Diameter Diameter Bilah 锯片直径	125mm (5")
--	------------

Hole Diameter Diameter Lubang 孔直径	20mm (13/16")
---	---------------

Max Cutting Capacity Kapasiti Pemotongan Maksimum 最大切割能力	90°: 40mm (1-9/16") 45°: 27mm
--	----------------------------------

No Load Speed (RPM) Kelajuan Tanpa Beban 回转速	8,800
--	-------

Dimensions (L x W x H) Dimensi 体积	283x158x172mm (11-1/8x6-1/4x6-3/4")
---	--

Net Weight Berat Bersih 淨重	2.5 - 3.0kg (5.5 - 6.6lbs.)
--------------------------------------	-----------------------------

Work Amount (approx.) Jumlah Kerja 工作量	16 m with BL1850B Cutting 600mm groove in brick Depth 10mm (Dry type 125mm Diamond Wheel)
--	--

* All list price shown are for reference only (exclude SST).

* Semua harga yang ditunjukkan adalah untuk rujukan sahaja (tidak termasuk SST). 所有显示的建议零售价仅供参考 (不包括SST)。

Cordless
Targeted Jobs

LED Flashlight
Lampu Saha LED
LED燈

Vacuum Cleaner
Pembersih Vakuum
吸尘器

Drilling / Fastening
Gantuli / Pasang
钻孔 / 紧固

Impact Drilling / Demolition
Gantuli / Hancurkan
冲击钻孔 / 拆除施工

Cutting
Pemotong
切割

Grinding / Sanding
Pengamiran / Pasir
研磨 / 砂磨

Sawing
Gergaji
锯切

Planing / Routing
Pengayutan / Tumpang
刨削 / 压花

Others
Lain-lain
其他

Outdoor Power Equipment
Alatan Kuat Luar
园机 / 户外



18V

LXT

Li-ion Ah 6.0 5.0 4.0 3.0 2.0 1.5

AWS

Auto - start Wireless System
Switch on the tool, and
Vacuum cleaner is activated

It has been impossible, but now Vacuum cleaner can be automatically activated by Cordless tools with our newly developed wireless system



Bluetooth AWS connects to power tool with Bluetooth

The Bluetooth® word mark and logos are registered trademarks owned by the Bluetooth SIG, Inc. and any use of such marks by Makita is under license. Other trademarks and trade names are those of their respective owners.

ADT

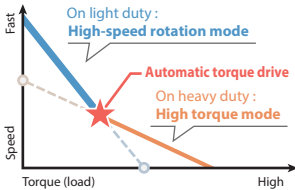

Automatically changes the cutting speed according to load conditions for an optimum operation

AFT

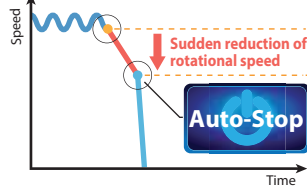

Shuts down the tool to protect the user, if the rotation speed suddenly slows down

BL MOTOR



Faster Cutting with High power and High torque brushless motor



Electric brake is activated after the tool is switched off

DGA414Z 100mm (4")

Cordless Angle Grinder
Pengisar Sudut Tanpa Kord
充电式角向磨光机



Top Slide Switch

Suis Gelangsar Atas 顶部滑动开关
Convenient for left & right handed
Mudah diguna dengan tangan kiri atau kanan 方便左右手



• Auto-start Wireless System (AWS) connects to compatible vacuum cleaners with Bluetooth

Standard Equipment: Grinding Wheel (A-80852), Wheel Cover, Side Grip, Lock Nut Wrench

• Z: Without Charger & Battery



Wheel Diameter Diameter Roda 轮片直径	100mm (4")
No Load Speed (RPM) Kelajuan Tanpa Beban 回转数	3,000 - 8,500
Dimensions (L x W x H) Dimensi 体积	BL1850B: 382x117x147mm (15"x4-5/8"x5-3/4")
Net Weight Berat Bersih 净重	2.2 - 2.8kg (4.9 - 6.3lbs.)
Continuous Usage Time (approx.) Masa Penggunaan Berterusan 连续使用时间	8 min with BL1850B Metal Sanding Pressing Load of 30N, 3000rpm

DGA418Z 100mm (4")

Cordless Angle Grinder
Pengisar Sudut Tanpa Kord
充电式角向磨光机



Paddle Switch

Suis Pemacu 扳机开关



• Auto-start Wireless System (AWS) connects to compatible vacuum cleaners with Bluetooth

Standard Equipment: Grinding Wheel (A-80852), Wheel Cover, Side Grip, Lock Nut Wrench

• Z: Without Charger & Battery



Wheel Diameter Diameter Roda 轮片直径	100mm (4")
No Load Speed (RPM) Kelajuan Tanpa Beban 回转数	3,000 - 8,500
Dimensions (L x W x H) Dimensi 体积	BL1850B: 382x117x146mm (15"x4-5/8"x5-3/4")
Net Weight Berat Bersih 净重	2.2 - 2.9kg (5.0 - 6.3lbs.)
Continuous Usage Time (approx.) Masa Penggunaan Berterusan 连续使用时间	8 min with BL1850B Metal Sanding Pressing Load of 30N, 3000rpm

* All list price shown are for reference only (exclude SST).

* Semua harga yang ditunjukkan adalah untuk rujukan sahaja (tidak termasuk SST). 所有显示的建议零售价仅供参考 (不包括SST)。

Cordless Target Kord 无绳式
LED Flashlight Lampu Suluh LED LED 照明灯
Vacuum Cleaner Pemilauhi (Vakuum) 吸尘器
Drilling / Fastening Druai / Pengikat 钻头 / 螺絲
Impact Drilling / Demolition Druai / Penembak 冲击钻 / 拆墙加工
Cutting Pemotong 切割
Grinding / Sanding Pengisar / Pasir 磨削 / 砂磨
Sawing Gergaji 电锯
Planing / Routing Pengisar / Tampakan 刨削 / 雕刻
Others Lain-lain 其他
Outdoor Power Equipment Alatan Kerja Luar 户外户外





Li-ion Ah 6.0 | 5.0 | 4.0 | 3.0 | 2.0 | 1.5

DGA419Z 100mm (4")

Cordless Angle Grinder
Pengisar Sudut Tanpa Kord
充电式角向磨光机

Paddle Switch
Suis Pemacu 扳机开关



- X-LOCK for toolless accessory changes

Standard Equipment: Grinding Wheel (E-00496), Wheel Cover, Side Grip

- Z: Without Charger & Battery



Wheel Diameter Diameter Roda 轮片直径	100mm (4")
Hole Diameter Diameter Lubang 孔直径	22.23mm (7/8")
Max Wheel Thickness Ketebalan Roda Maksimum 最大轮片厚度	6mm (1/4")
No Load Speed (RPM) Kelajuan Tanpa Beban 回转数	3,000 - 8,500
Dimensions (L x W x H) Dimensi 体积	396x117x147mm (15-1/2"x4-5/8"x5-3/4")
Net Weight Berat Bersih 净重	2.4 - 3.0kg (5.3 - 6.6lbs.)

DGA411Z 100mm (4")

Cordless Angle Grinder
Pengisar Sudut Tanpa Kord
充电式角向磨光机

Top Slide Switch
Suis Gelangsar Atas 顶部滑动开关

Convenient for left & right handed
Mudah diguna dengan tangan kiri atau kanan 方便左右手操作



- Spiral bevel gear for more efficient transfer of energy

Standard Equipment: Grinding Wheel (A-80852), Wheel Cover, Side Grip, Lock Nut Wrench

- Z: Without Charger & Battery



Wheel Diameter Diameter Roda 轮片直径	100mm (4")
No Load Speed (RPM) Kelajuan Tanpa Beban 回转数	3,000 - 8,500
Dimensions (L x W x H) Dimensi 体积	BL1850B: 382x117x140mm (15-1/4"x4-5/8"x5-1/2")
Net Weight Berat Bersih 净重	2.2 - 2.8kg (4.8 - 6.1lbs.)
Continuous Usage Time (approx.) Masa Penggunaan Berterusan 连续使用时间	8 min with BL1850B Metal Sanding Pressing Load of 30N, 3000rpm

DGA406RME | DGA406RFE | DGA406Z 100mm (4")

Cordless Angle Grinder
Pengisar Sudut Tanpa Kord
充电式角向磨光机

Top Slide Switch
Suis Gelangsar Atas 顶部滑动开关

Convenient for left & right handed
Mudah diguna dengan tangan kiri atau kanan 方便左右手操作



- Electric brake for increased operator safety

Standard Equipment: Grinding Wheel (A-80852), Wheel Cover, Side Grip, Lock Nut Wrench

- RME: 1x Rapid Charger, 2x 4.0Ah Battery
- RFE: 1x Rapid Charger, 2x 3.0Ah Battery
- Z: Without Charger, Battery & Carrying Case



Wheel Diameter Diameter Roda 轮片直径	100mm (4")
No Load Speed (RPM) Kelajuan Tanpa Beban 回转数	8,500
Dimensions (L x W x H) Dimensi 体积	362x117x146mm (14-1/4"x4-5/8"x5-3/4")
Net Weight Berat Bersih 净重	2.18 - 2.77kg (4.81 - 6.12lbs)
Work Amount (approx.) Jumlah Kerja 工作量	12 m with BL1850B Cutting Concrete Depth 10mm

DGA408RME | DGA408RFE | DGA408Z 100mm (4")

Cordless Angle Grinder
Pengisar Sudut Tanpa Kord
充电式角向磨光机

Paddle Switch
Suis Pemacu 扳机开关



- Efficiency for heavy-duty grinding applications

Standard Equipment: Grinding Wheel (A-80852), Wheel Cover, Side Grip, Lock Nut Wrench

- RME: 1x Rapid Charger, 2x 4.0Ah Battery
- RFE: 1x Rapid Charger, 2x 3.0Ah Battery
- Z: Without Charger, Battery & Carrying Case



Wheel Diameter Diameter Roda 轮片直径	100mm (4")
No Load Speed (RPM) Kelajuan Tanpa Beban 回转数	8,500
Dimensions (L x W x H) Dimensi 体积	362x117x146mm (14-1/4"x4-5/8"x5-3/4")
Net Weight Berat Bersih 净重	2.18 - 2.80kg (4.81 - 6.17lbs)
Work Amount (approx.) Jumlah Kerja 工作量	12 m with BL1850B Cutting Concrete Depth 10mm

DGA404RTE | DGA404RFE | DGA404Z 100mm (4")

Cordless Angle Grinder
Pengisar Sudut Tanpa Kord
充电式角向磨光机

Top Slide Switch
Suis Gelangsar Atas 顶部滑动开关

Convenient for left & right handed
Mudah diguna dengan tangan kiri atau kanan 方便左右手操作



- Efficient internal cooling for optimum performance

Standard Equipment: Grinding Wheel (A-80852), Wheel Cover, Side Grip, Lock Nut Wrench

- RTE: 1x Rapid Charger, 2x 5.0Ah Battery
- RFE: 1x Rapid Charger, 2x 3.0Ah Battery
- Z: Without Charger, Battery & Carrying Case



Wheel Diameter Diameter Roda 轮片直径	100mm (4")
No Load Speed (RPM) Kelajuan Tanpa Beban 回转数	8,500
Dimensions (L x W x H) Dimensi 体积	362x117x140mm (14-1/4"x4-5/8"x5-1/2")
Net Weight Berat Bersih 净重	2.10 - 2.71kg (4.63 - 5.98lbs)
Work Amount (approx.) Jumlah Kerja 工作量	12 m with BL1850B Cutting Concrete Depth 10mm



VIDEO CLIP
Models and specs may vary by country

* All list price shown are for reference only (exclude SST).

* Semua harga yang ditunjukkan adalah untuk rujukan sahaja (tidak termasuk SST). 所有显示的建议零售价仅供参考 (不包括SST)。

Cordless
Targeted Jobs

LED Flashlight
Lampu Suhu LED
LED照明灯

Vacuum Cleaner
Pembersih Vakuum
吸尘器

Drilling / Fastening
Gantuli / Pasang
钻孔 / 紧固

Impact Drilling / Demolition
Gantuli / Hancurkan
冲击钻孔 / 拆除施工

Cutting
Memotong
切割

Grinding / Sanding
Pengisar / Pasah
研磨 / 砂磨

Sawing
Gigit
锯切

Planing / Routing
Pengayuh / Tanggah
刨削 / 雕刻

Others
Lain-lain
其他

Outdoor Power Equipment
Alatan Kuasa Luar
园具 / 户外





Li-ion Ah 6.0 5.0 4.0 3.0 2.0 1.5

DGA405RFE DGA405Z 100mm (4")

Cordless Angle Grinder
Pengisar Sudut Tanpa Kord
充电式角向磨光机



Paddle Switch
Suis Pemacu 扳机开关



- Efficient internal cooling for optimum performance

Standard Equipment: Grinding Wheel (A-80852), Wheel Cover, Side Handle, Lock Nut Wrench

- RFE: 1x Rapid Charger, 2x 3.0Ah Battery
- Z: Without Charger, Battery & Carrying Case



Wheel Diameter Diameter Roda 轮片直径	100mm (4")
No Load Speed (RPM) Kelajuan Tanpa Beban 回转速数	8,500
Dimensions (L x W x H) Dimensi 体积	362x117x140mm (14-1/4"x4-5/8"x5-1/2")
Net Weight Berat Bersih 淨重	2.08 - 2.69kg (4.59 - 5.94lbs)
Work Amount (approx.) Jumlah Kerja 工作量	12 m with BL1850B Cutting Concrete Depth 10mm

DGA402RFE DGA402Z 100mm (4")

430 WATT

Cordless Angle Grinder
Pengisar Sudut Tanpa Kord
充电式角向磨光机



Top Slide Switch
Suis Gelangsar Atas 顶部滑动开关
Convenient for left & right handed
Mudah diguna dengan tangan kiri atau kanan 方便左右手



- Spiral bevel gear for more efficient transfer of energy

Standard Equipment: Grinding Wheel (A-80852), Wheel Cover, Side Grip, Lock Nut Wrench

- RFE: 1x Rapid Charger, 2x 3.0Ah Battery
- Z: Without Charger, Battery & Carrying Case



Wheel Diameter Diameter Roda 轮片直径	100mm (4")
No Load Speed (RPM) Kelajuan Tanpa Beban 回转速数	11,000
Dimensions (L x W x H) Dimensi 体积	317x118x118mm (12-1/2"x4-5/8"x4-5/8")
Net Weight Berat Bersih 淨重	1.90 - 2.51kg (4.19 - 5.5 lbs)
Work Amount (approx.) Jumlah Kerja 工作量	13.5 m with BL1850B Cutting Concrete Depth 5mm

DGA456RFE DGA456Z 115mm (4-1/2")

Cordless Angle Grinder
Pengisar Sudut Tanpa Kord
充电式角向磨光机



Top Slide Switch
Suis Gelangsar Atas 顶部滑动开关
Convenient for left & right handed
Mudah diguna dengan tangan kiri atau kanan 方便左右手



- Efficiency for heavy-duty grinding applications

Standard Equipment: Grinding Wheel (A-80640), Wheel Cover, Side Handle, Lock Nut Wrench

- RFE: 1x Rapid Charger, 2x 3.0Ah Battery
- Z: Without Charger, Battery & Carrying Case



Wheel Diameter Diameter Roda 轮片直径	115mm (4-1/2")
No Load Speed (RPM) Kelajuan Tanpa Beban 回转速数	8,500
Dimensions (L x W x H) Dimensi 体积	362x130x151mm (14-1/4"x5-1/8"x5-15/16")
Net Weight Berat Bersih 淨重	2.34 - 3.03kg (5.17 - 6.67lbs)
Work Amount (approx.) Jumlah Kerja 工作量	12 m with BL1850B Cutting Concrete Depth 10mm

DGA458RFE DGA458Z 115mm (4-1/2")

Cordless Angle Grinder
Pengisar Sudut Tanpa Kord
充电式角向磨光机



Paddle Switch
Suis Pemacu 扳机开关



- Electric brake for increased operator safety

Standard Equipment: Grinding Wheel (A-80640), Wheel Cover, Side Handle, Lock Nut Wrench

- RFE: 1x Rapid Charger, 2x 3.0Ah Battery
- Z: Without Charger, Battery & Carrying Case



Wheel Diameter Diameter Roda 轮片直径	115mm (4-1/2")
No Load Speed (RPM) Kelajuan Tanpa Beban 回转速数	8,500
Dimensions (L x W x H) Dimensi 体积	362x130x151mm (14-1/4"x5-1/8"x5-15/16")
Net Weight Berat Bersih 淨重	2.34 - 3.03kg (5.17 - 6.67lbs)
Work Amount (approx.) Jumlah Kerja 工作量	12 m with BL1850B Cutting Concrete Depth 10mm

DGA452RME DGA452RFE DGA452Z 115mm (4-1/2")

430 WATT

Cordless Angle Grinder
Pengisar Sudut Tanpa Kord
充电式角向磨光机



Top Slide Switch
Suis Gelangsar Atas 顶部滑动开关
Convenient for left & right handed
Mudah diguna dengan tangan kiri atau kanan 方便左右手



- Compact barrel grip for easy handling

Standard Equipment: Grinding Wheel (A-80640), Wheel Cover, Side Handle, Lock Nut Wrench

- RME: 1x Rapid Charger, 2x 4.0Ah Battery
- RFE: 1x Rapid Charger, 2x 3.0Ah Battery
- Z: Without Charger, Battery & Carrying Case



Wheel Diameter Diameter Roda 轮片直径	115mm (4-1/2")
No Load Speed (RPM) Kelajuan Tanpa Beban 回转速数	11,000
Dimensions (L x W x H) Dimensi 体积	317x129x126mm (12-1/2"x5-1/8"x5")
Net Weight Berat Bersih 淨重	2.06 - 2.71kg (4.53 - 5.97lbs)
Work Amount (approx.) Jumlah Kerja 工作量	25 m with BL1850B Cutting Concrete Depth 5mm

* All list price shown are for reference only (exclude SST).

* Semua harga yang ditunjukkan adalah untuk rujukan sahaja (tidak termasuk SST). 所有显示的建议零售价仅供参考 (不包括SST)。

Cordless Target Kord 无绳
LED Flashlight Lampu Suluh LED LED 照明灯
Vacuum Cleaner Pemilauhi Vakuüm 吸尘器
Drilling / Fastening Daurul / Pengikat 钻孔 / 紧固
Impact Drilling / Demolition Daurul / Penembak 冲击钻孔 / 拆除加工
Cutting Pemotong 切割
Grinding / Sanding Pengisar / Pasukan 磨削 / 研磨
Sawing Gergaji 电锯
Planing / Routing Pengisar / Tangkap 刨削 / 雕刻
Others Lain-lain 其他
Outdoor Power Equipment Alatan Kerja Luar 户外动力设备
Makita



Li-ion Ah 6.0 5.0 4.0 3.0 2.0 1.5

DGA519Z 125mm (5")

Cordless Angle Grinder
Pengisar Sudut Tanpa Kord
充电式角向磨光机



Paddle Switch
Suis Pemacu 扳机开关



- X-LOCK for toolless accessory changes

Standard Equipment: Grinding Wheel (E-00402),
Wheel Cover, Side Grip

- Z: Without Charger & Battery



Wheel Diameter Diameter Roda 轮片直径	125mm (5")
Hole Diameter Diameter Lubang 孔直径	22.23mm (7/8")
Max Wheel Thickness Ketebalan Roda Maksimum 最大轮片厚度	6mm (1/4")
No Load Speed (RPM) Kelajuan Tanpa Beban 回转数	3,000 - 8,500
Dimensions (L x W x H) Dimensi 体积	396x140x147mm (15-1/2"x5-1/2"x5-3/4")
Net Weight Berat Bersih 净重	2.5 - 3.1kg (5.5 - 6.8lbs.)

DGA511Z 125mm (5")

Cordless Angle Grinder
Pengisar Sudut Tanpa Kord
充电式角向磨光机



Top Slide Switch
Suis Gelangsar Atas 顶部滑动开关
Convenient for left & right handed
Mudah diguna dengan tangan kiri atau kanan 方便左右手操作



- Spiral bevel gear for more efficient transfer of energy

Standard Equipment: Grinding Wheel (A-80656), Wheel Cover,
Side Grip, Lock Nut Wrench

- Z: Without Charger & Battery



Wheel Diameter Diameter Roda 轮片直径	125mm (5")
No Load Speed (RPM) Kelajuan Tanpa Beban 回转数	3,000 - 8,500
Dimensions (L x W x H) Dimensi 体积	BL1850B: 382x140x145mm (15"x5-1/2"x5-3/4")
Net Weight Berat Bersih 净重	2.3 - 3.0kg (5.1 - 6.6lbs.)
Work Amount (approx.) Jumlah Kerja 工作量	13.8 m with BL1850B Cutting Concrete Depth 10mm

DGA514Z 125mm (5")

Cordless Angle Grinder
Pengisar Sudut Tanpa Kord
充电式角向磨光机

Top Slide Switch
Suis Gelangsar Atas 顶部滑动开关
Convenient for left & right handed
Mudah diguna dengan tangan kiri atau kanan 方便左右手操作



- Auto-start Wireless System (AWS) connects to compatible vacuum cleaners with Bluetooth

Standard Equipment: Grinding Wheel (A-80656), Wheel Cover,
Side Grip, Lock Nut Wrench

- Z: Without Charger & Battery



Wheel Diameter Diameter Roda 轮片直径	125mm (5")
No Load Speed (RPM) Kelajuan Tanpa Beban 回转数	3,000 - 8,500
Dimensions (L x W x H) Dimensi 体积	BL1850B: 382x140x151mm (15"x5-1/2"x5-15/16")
Net Weight Berat Bersih 净重	2.4 - 3.0kg (5.2 - 6.7lbs.)
Work Amount (approx.) Jumlah Kerja 工作量	13.8 m with BL1850B Cutting Concrete Depth 10mm

DGA518Z 125mm (5")

Cordless Angle Grinder
Pengisar Sudut Tanpa Kord
充电式角向磨光机



Paddle Switch
Suis Pemacu 扳机开关



- Auto-start Wireless System (AWS) connects to compatible vacuum cleaners with Bluetooth

Standard Equipment: Grinding Wheel (A-80656), Wheel Cover,
Side Grip, Lock Nut Wrench

- Z: Without Charger & Battery



Wheel Diameter Diameter Roda 轮片直径	125mm (5")
No Load Speed (RPM) Kelajuan Tanpa Beban 回转数	3,000 - 8,500
Dimensions (L x W x H) Dimensi 体积	BL1850B: 382x140x151mm (15"x5-1/2"x6")
Net Weight Berat Bersih 净重	2.4 - 3.1kg (5.3 - 6.8lbs.)
Work Amount (approx.) Jumlah Kerja 工作量	13.8 m with BL1850B Cutting Concrete Depth 10mm

DGA508RFE | **DGA508Z** 125mm (5")

Cordless Angle Grinder
Pengisar Sudut Tanpa Kord
充电式角向磨光机



Paddle Switch
Suis Pemacu 扳机开关



- Electric brake for increased operator safety

Standard Equipment: Grinding Wheel (A-80656), Wheel Cover,
Side Handle, Lock Nut Wrench

- RFE: 1x Rapid Charger, 2x 3.0Ah Battery
- Z: Without Charger, Battery & Carrying Case



Wheel Diameter Diameter Roda 轮片直径	125mm (5")
No Load Speed (RPM) Kelajuan Tanpa Beban 回转数	8,500
Dimensions (L x W x H) Dimensi 体积	362x140x151mm (14-1/4"x5-1/2"x5-15/16")
Net weight Berat Bersih 净重	2.35 - 3.83kg (5.18 - 8.45lbs)
Work Amount (approx.) Jumlah Kerja 工作量	13.8 m with BL1850B Cutting Concrete Depth 10mm

* All list price shown are for reference only (exclude SST).

* Semua harga yang ditunjukkan adalah untuk rujukan sahaja (tidak termasuk SST). 所有显示的建议零售价仅供参考 (不包括SST)。

Cordless
Tanpa Kord 无绳

LED Flashlight
Lampu Suhu LED
LED照明灯

Vacuum Cleaner
Pembersih Vakuum
吸尘器

Drilling / Fastening
Gantuli / Pasang
钻孔 / 紧固

Impact Drilling / Demolition
Gantuli / Persekit
冲击钻孔 / 拆除

Cutting
Panas
切割

Grinding / Sanding
Pengisar / Pasir
研磨 / 砂磨

Sawing
Gigit
锯切

Planing / Routing
Pegangan / Tangan
刨削 / 雕刻

Others
Lain-lain
其他

Outdoor Power Equipment
Alatan Kuasa Luar
户外动力

Thakita
18V



Li-ion Ah 6.0 | 5.0 | 4.0 | 3.0 | 2.0 | 1.5

DGA505RFE | DGA505Z 125mm (5")

Cordless Angle Grinder
Pengisar Sudut Tanpa Kord
充电式角向磨光机



Paddle Switch
Suis Pemacu 扳机开关



- Efficient internal cooling for optimum performance

Standard Equipment: Grinding Wheel (A-80656), Wheel Cover, Side Handle, Lock Nut Wrench

- RFE: 1x Rapid Charger, 2x 3.0Ah Battery
- Z: Without Charger, Battery & Carrying Case



Wheel Diameter Diameter Roda 轮片直径	125mm (5")
No Load Speed (RPM) Kelajuan Tanpa Beban 回转数	8,500
Dimensions (L x W x H) Dimensi 体积	362x140x145mm (14-1/4"x5-1/2"x5-3/4")
Net weight Berat Bersih 淨重	2.26 - 3.73kg (4.98 - 8.23lbs)
Work Amount (approx.) Jumlah Kerja 工作量	13.8 m with BL1850B Cutting Concrete Depth 10mm

Model No. 型号			No Load Speed (rpm) Kelajuan Tanpa Beban 回转数	Switch Suis 开关	BL MOTOR	AFT	ADT	GRAB	AWS	Anti-restart function Fungsi restart semua 防撞功能	XLOCK
100mm	115mm	125mm									
DGA414	-	DGA514	3,000 - 8,500	Slide	•	•	•	•	•	•	
DGA411	-	DGA511	3,000 - 8,500	Slide	•	•	•			•	
DGA406	DGA456	-	8,500	Slide	•	•	•	•		•	
DGA404	-	-	8,500	Slide	•	•	•			•	
DGA402	DGA452	-	11,000	Slide						•	
DGA419	-	DGA519	3,000 - 8,500	Paddle	•	•	•	•		•	•
DGA418	-	DGA518	3,000 - 8,500	Paddle	•	•	•	•	•	•	
DGA405	-	DGA505	8,500	Paddle	•	•	•			•	
DGA408	DGA458	DGA508	8,500	Paddle	•	•	•	•		•	

DGD800Z

430 W

Cordless Die Grinder
Pengisar Tanpa Kord
充电式刻磨机

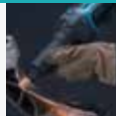

- Slide switch with lock-on for operator convenience

Standard Equipment: Wrench x2

- Z: Without Charger & Battery

Capacity Kapasiti 能力	Collet : 3mm - 8mm
Wheel Diameter Diameter Roda 轮片直径	38mm (1-1/2")
No Load Speed (RPM) Kelajuan Tanpa Beban 回转数	26,000
Dimensions (L x W x H) Dimensi 体积	402x82x118mm (15-3/4"x3-1/4"x4-5/8")
Net Weight Berat Bersih 淨重	1.7 - 2.2kg (3.8 - 4.9lbs)
Work Amount (approx.) Jumlah Kerja 工作量	9.0 g with BL1850B Grinding Steel Plate SS400

DGD801Z

430 W

Cordless Die Grinder
Pengisar Tanpa Kord
充电式刻磨机



- Round collet nut reduces the risk of damages

Standard Equipment: Wrench x2

- Z: Without Charger & Battery

Capacity Kapasiti 能力	Collet : 3mm - 8mm
Wheel Diameter Diameter Roda 轮片直径	38mm (1-1/2")
No Load Speed (RPM) Kelajuan Tanpa Beban 回转数	25,000
Dimensions (L x W x H) Dimensi 体积	307x82x118mm (12-1/8"x3-1/4"x4-5/8")
Net Weight Berat Bersih 淨重	1.5 - 2.0kg (3.3 - 4.3lbs)
Work Amount (approx.) Jumlah Kerja 工作量	9.5 g with BL1850B Grinding Steel Plate SS400

DPO600Z | DPO500Z

Cordless Random Orbit Polisher
Pelicin Orbit Tanpa Kord
充电式砂光机



- Selectable two rotation mode: normal mode & finishing mode

Standard Equipment: Hex Wrench

- Z: Without Charger & Battery



Pad Size Saiz Pad 垫子尺寸	150mm (6") DPO600 125mm (5") DPO500
Orbits Per Minute (OPM) Bilangan Putaran 轨道转速	Normal mode: 0 - 6,800 Finishing mode: 0 - 5,200
Strokes Per Minute (SPM) Kelajuan Strok 冲程速度	Normal mode: 0 - 13,600 Finishing mode: 0 - 10,400
No Load Speed (RPM) Kelajuan Tanpa Beban 回转数	Normal mode: 0 - 780 Finishing mode: 0 - 600
Orbit Diameter Kelajuan Tanpa Beban 回转数	5.5mm (7/32")
Dimensions (L x W x H) Dimensi 体积	530x148x126mm DPO600 (20-7/8"x5-7/8"x5") 530x123x134mm DPO500 (20-7/8"x4-7/8"x5-1/4")
Net Weight Berat Bersih 淨重	3.1 - 3.6kg (6.8 - 7.9lbs.)
Continuous Usage Time (approx.) Masa Penggunaan Berterusan 连续使用时间	30min with BL1860B Finishing Mode

* All list price shown are for reference only (exclude SST).

* Semua harga yang ditunjukkan adalah untuk rujukan sahaja (tidak termasuk SST). 所有显示的建议零售价仅供参考 (不包括SST)。

Cordless
Target Kord 无绳式

LED Flashlight
Lampu Suluh LED
LED 照明灯

Vacuum Cleaner
Pembersih Vakuum
吸尘器

Drilling / Fastening
Drauli / Pasang
钻孔 / 紧固

Impact Drilling / Demolition
Drauli / Perseki
起工钻孔 / 拆墙加工

Cutting
Pemotong
切割

Grinding / Sanding
Pengisar / Pasir
打磨 / 砂磨

Sawing
Gergaji
锯切

Planing / Routing
Pengaram / Tangkai
刨削 / 雕刻

Others
Lain-lain
其他

Outdoor Power Equipment
Alatan Kerja Luar
园机-户外

Makita
Makita



Li-ion Ah 6.0 5.0 4.0 3.0 2.0 1.5

DPV300Z

Cordless Sander Polisher
Penggilap Tanpa Kord
充电式打蜡抛光机



- Electronic speed control maintains constant speed under load, critical for a professional finish

Standard Equipment: Side Grip, Pad, Adapter, Wool Pad, Sponge Pad

• Z: Without Charger & Battery



Pad / Disc Diameter Diameter Pad / Cakera 垫/盘直径	Hook & Loop Style: 80mm (3-1/8") Twist-On / Twist-Off Style: 50mm (2")
Backing Pad Diameter Diameter Pad 衬垫直径	Hook & Loop Style: 75mm (2-15/16") Twist-On / Twist-Off Style: 46mm (1-13/16")
Head Length Panjang Kepala 头长度	127 mm (5")
No Load Speed (RPM) Kelajuan Tanpa Beban 回转数	Polishing: 0 - 2,800 Sanding: 0 - 9,500
Dimensions (L x W x H) Dimensi 体积	160x79x256mm (6-5/16x3-1/8x10-1/8")
Net Weight Berat Bersih 净重	2.0 - 2.6kg (4.4 - 5.7lbs.)
Continuous Usage Time (approx.) Masa Penggunaan Berterusan 连续使用时间	34min with BL1850B

DBS180Z 9mm x 533mm (3/8" x 21")

Cordless Belt Sander
Pelicin Pita Tanpa Kord
充电式带式砂光机



- High power BL motor provides high performance

Standard Equipment: Sanding Belt, Grip, Grip Base

• Z: Without Charger & Battery



Belt Width Lebar Pita 砂带宽度	6mm (1/4") 9mm (3/8") 13mm (1/2")
Belt Length Panjang Pita 砂带长度	533mm (21")
Belt Speed Kelajuan Pita 砂带速度	600 - 1,700 m/min
Dimensions (L x W x H) Dimensi 体积	500x96x116mm (19-3/4x3-3/4x4-9/16")
Net Weight Berat Bersih 净重	1.8 - 2.1kg (4.0 - 4.6lbs.)



DSL800Z 225mm (8-7/8")

Cordless Drywall Sander
Pelicin Drywall Tanpa Kord
充电式石膏板砂光机



- Easy handling by cordless

Standard Equipment: Abrasive Disc, Hex Wrench, Tool Bag

• Z: Without Charger & Battery



Pad diameter Diameter Pad 垫片直径	210mm (8-1/4")
Abrasive Disc Size Saiz Cakera 磨盘尺寸	225mm (8-7/8")
No Load Speed (RPM) Kelajuan Tanpa Beban 回转数	1,000 - 1,800
Dimensions (L x W x H) Dimensi 体积	1,100-1,520x259x273mm (43-1/4"-59-3/4"x10-1/4"x10-3/4")
Net Weight Berat Bersih 净重	4.5 - 5.7kg (10.0 - 12.6lbs.)
Continuous Usage Time (approx.) Masa Penggunaan Berterusan 连续使用时间	35 min with BL1850B Speed Dial 3



DSL801Z 225mm (8-7/8")

Cordless Drywall Sander
Pelicin Drywall Tanpa Kord
充电式石膏板砂光机



- Redesigned dust collection brush reduces dust leakage

Standard Equipment: 1pc Abrasive Disc #120, Hex Wrench, Tool Bag (195638-5)(without inner tray)

• Z: Without Charger & Battery



Pad diameter Diameter Pad 垫片直径	210mm (8-1/4")
Abrasive Disc Size Saiz Cakera 磨盘尺寸	225mm (8-7/8")
No Load Speed (RPM) Kelajuan Tanpa Beban 回转数	1,000 - 1,800
Dimensions (L x W x H) Dimensi 体积	1,100-1,520x259x273mm (43-1/4"-59-3/4"x10-1/4"x10-3/4")
Net Weight Berat Bersih 净重	4.5 - 5.7kg (10.0 - 12.6lbs.)
Continuous Usage Time (approx.) Masa Penggunaan Berterusan 连续使用时间	35 min with BL1850B Speed Dial 3

DBO380RTJ | **DBO380Z**

Cordless Finishing Sander
Pengampelas Tanpa Kord
充电式砂光机



- High capacity dust box with built-in vacuum adaptor for improved dust collection

Standard Equipment: Dust Box, Punch Plate, Abrasive Paper Grit 120 x1, Battery Protector

• RTJ: 1x Rapid Charger, 2x 5.0Ah Battery, 1x Makpac Connector Box
• Z: Without Charger & Battery



Pad Size Saiz Pad 垫子尺寸	93 x 185mm (3-5/8x7-1/4")
Abrasive Paper Size Saiz Kertas Pasir 砂纸尺寸	Rectangular: 93 x 228mm (3-5/8x9")
Orbits Per Minute (OPM) Bilangan Putaran 轨道转速	4,000, 8,000, 12,000
Strokes Per Minute (SPM) Kelajuan Strok 冲程速度	8,000, 16,000, 24,000
Orbit Diameter Jejaki Diameter 轨道直径	2.0mm (1/16")
Dimensions (L x W x H) Dimensi 体积	336x92x169mm (13-1/4x3-5/8x6-5/8")
Net Weight Berat Bersih 净重	1.9 - 2.2kg (4.2 - 4.9lbs.)
Continuous Usage Time (approx.) Masa Penggunaan Berterusan 连续使用时间	58 min with BL1860B

* All list price shown are for reference only (exclude SST).

* Semua harga yang ditunjukkan adalah untuk rujukan sahaja (tidak termasuk SST). 所有显示的建议零售价仅供参考 (不包括SST)。

Cordless
Target: Wood Surface

LED Flashlight
Lampu Suhu LED
LED明亮

Vacuum Cleaner
Pembersih Vakuum
吸尘器

Drilling / Fastening
Ganda / Pasak
钻孔 / 紧固

Impact Drilling / Demolition
Ganda / Pasak
石工钻孔 / 建筑施工

Cutting / Finishing
Pangkas
切割 / 打磨

Grinding / Sanding
Pangkas / Pasak
研磨 / 砂磨

Sanding / Grinding
Ganda / Pasak
打磨 / 研磨

Planing / Routing
Pangkas / Pasak
刨平 / 铣削

Others
Lain-lain
其他

Outdoor Power Equipment
Alatan Kuat Luar
园机 / 户外

Others
Lain-lain
其他



18V

LXT

Li-ion Ah 6.0 | 5.0 | 4.0 | 3.0 | 2.0 | 1.5

DBO180Z 125mm (5")**Cordless Random Orbit Sander**Pelicin Orbit Tanpa Kord
充电式砂光机

- Three speed control switch fast, medium and low

Standard Equipment: Abrasive Paper, Dust Bag

- Z : Without Charger & Battery



Pad Diameter Diameter Pad 垫片直径	123mm (4-7/8")
Abrasive Disc Size Saiz Cakera 磨盘尺寸	125mm (5")
Orbits Per Minute (OPM) Bilangan Putaran 轨道转速	7,000 9,500 11,000
Dimensions (L x W x H) Dimensi 体积	175x123x153mm (6-7/8"x4-7/8"x6")
Net Weight Berat Bersih 淨重	1.4 - 1.7kg (3.0 - 3.7lbs)
Continuous Usage Time (approx.) Masa Penggunaan Berterusan 连续使用时间	66 min with BL1850B Low Speed Sanding

DTM52RTJX1 | **DTM52Z****Cordless Multi Tool**Pemotong dan Pengisar Pelbagai
Fungsi Tanpa Kord
充电式多功能切割打磨机

- Compatible with STARLOCK / STARLOCK PLUS / STARLOCK MAX
- DTM52RTJX1: Dust Attachment Set (191R02-6), Oscillating Multi Tool Accessories and Plastic Case, TMA059 Plunge Cut Saw Blade 32 (B-64939), TMA047 Bow Shape Plunge Cut Saw Blade 32 (B-64814), MAM001 Bow Shape Plunge Cut Saw Blade (B-66400), TMA045 Segment Saw Blade 85 (B-64799), TMA078 Sanding Pad (B-65115), Abrasive Paper Grit 60, 100, 150 (10pcs each Grit)
- RTJX1: 1x Rapid Charger, 2x 5.0Ah Battery, 1x Makpac Connector Box
- Z: Without Charger, Battery & Carrying Case



For DTM52RTJX1 only



Oscillations Per Minute (OPM) Kelajuan Ayunan 摆动速度	10,000 - 20,000
Oscillation Angle Sudut Ayunan 摆动角度	Left: 1.8° Right: 1.8° Total: 3.6°
Shank Type Jenis Shank 刀柄类型	Multi Tool: STARLOCK MAX
Dimensions (L x W x H) Dimensi 体积	322x95x126mm (12-5/8"x3-3/4"x5")
Net Weight Berat Bersih 淨重	1.7 - 2.0kg (3.7 - 4.4lbs.)
Work Amount (approx.) Jumlah Kerja 工作量	320 cuts with BL1860B 38mm thick SPF

DTM51RFX8 | **DTM51Z****Cordless Multi Tool**Pemotong dan Pengisar Pelbagai
Fungsi Tanpa Kord
充电式多功能切割打磨机

- 12 Angle settings at every 30° from 0° to 360°

Standard Equipment: DTM51RFX8: Oscillating multi tool accessories, Tool Box

- RFX8: 1x Rapid Charger, 2x 3.0Ah Battery
- Z: Without Charger, Battery & Carrying Case



For DTM51RFX8 only



Oscillations Per Minute (OPM) Kelajuan Ayunan 摆动速度	6,000 - 20,000
Oscillation Angle Sudut Ayunan 摆动角度	Left: 1.6° Right: 1.6° Total: 3.2°
Dimensions (L x W x H) Dimensi 体积	340x80x122mm (13-3/8"x3-1/8"x4-13/16")
Net Weight Berat Bersih 淨重	2.0 - 2.4kg (4.4 - 5.3lbs)
Work Amount (approx.) Jumlah Kerja 工作量	40 pcs with BL1850B Cutting

DTM50Z**Cordless Multi Tool**Pemotong dan Pengisar Pelbagai
Fungsi Tanpa Kord
充电式多功能切割打磨机

- High operating efficiency

Standard Equipment: Hex Wrench

- Z : Without Charger & Battery



Oscillations Per Minute (OPM) Kelajuan Swing 摆动速度	6,000 - 20,000
Dimensions (L x W x H) Dimensi 体积	307x80x122mm (12-1/4"x3-1/8"x4-13/16")
Net Weight Berat Bersih 淨重	1.8 - 2.2kg (3.9 - 4.8lbs)
Work Amount (approx.) Jumlah Kerja 工作量	35 pcs with BL1850B Cutting

DLS600Z 165mm (6-1/2")**Cordless Compound Miter Saw**Gergaji Kompoun Miter Tanpa Kord
充电式斜断锯

- High accuracy & Lightweight

Standard Equipment: TCT Saw Blade (B-56487), Dust Bag, Vertical Vise, Hex Wrench, Triangular Rule

- Z : Without Charger & Battery



Blade Diameter Diameter Bilah 锯片直径	165mm (6-1/2")
Miter Angle Sudut Miter 斜接角	52°L / 52°R
Bevel Angle Sudut Bevel 斜角	46°L / 46°R
Max Cutting Capacity Kapasiti Pemotongan Maksimum 最大切割能力	90° Miter: 46 x 92mm (1-13/16" x 3-5/8") 45° Miter, L/R: 46 x 65mm (1-13/16" x 2-9/16")
No Load Speed (RPM) Kelajuan Tanpa Beban 回转数	5,000
Dimensions (L x W x H) Dimensi 体积	340x400x440mm (13-3/8"x15-3/4"x17-1/4")
Net Weight Berat Bersih 淨重	6.3 - 6.6kg (13.9 - 14.6lbs)
Work Amount (approx.) Jumlah Kerja 工作量	625 pcs with BL1850B Sawing (Round Wood Height 15 x 90mm Thick)

* All list price shown are for reference only (exclude SST).

* Semua harga yang ditunjukkan adalah untuk rujukan sahaja (tidak termasuk SST). 所有显示的建议零售价仅供参考 (不包括SST)。



Li-ion Ah 6.0 5.0 4.0 3.0 2.0 1.5

DLS713RME | DLS713Z 190mm (7-1/2") 441 mm

Cordless Slide Compound Miter Saw

Gergaji Gelongsor Komaun Miter Tanpa Kord
充电式斜断锯 (滑动复合式)



- Powerful Makita-built motor

Standard Equipment: TCT Saw Blade (A-86147), Vertical Vise, Socket Wrench, Triangular Rule, Dust Bag, Holder Set

- RME: 1x Rapid Charger, 2x 4.0Ah Battery
- Z: Without Charger & Battery



Blade Diameter Diameter Bilah 锯片直径	190mm (7-1/2")
Miter Angle Sudut Miter 斜接角	47°L / 57°R
Bevel Angle Sudut Bevel 斜角	45°L / 5°R
Max Cutting Capacity Kapasiti Pemotongan Maksimum 最大切割能力	90°: 52 x 300mm (2-1/16" x 11-3/4")
No Load Speed (RPM) Kelajuan Tanpa Beban 回转数	2,200
Dimensions (L x W x H) Dimensi 体积	655x430x454mm (25-3/4"x17"x17-7/8")
Net Weight Berat Bersih 净重	12.1kg (26.7lbs)
Work Amount (approx.) Jumlah Kerja 工作量	300 pcs with BL1850B Sawing (Merbau Decking 90 x 19mm)

DHS661RFJ | DHS661Z 165mm (6-1/2")

Cordless Circular Saw

Gergaji Piring Tanpa Kord
充电式圆锯



- Compact and Lightweight Design for Better Maneuverability

Standard Equipment: TCT Saw Blade (B-63018), Hex Wrench, Rip Fence (Guide Rule), Dust Nozzle

- RFJ: 1x Rapid Charger, 2x 3.0Ah Battery, 1x Makpac Connector Box
- Z: Without Charger, Battery & Carrying Case



Blade Diameter Diameter Bilah 锯片直径	165mm (6-1/2")
Hole Diameter Diameter Lubang 孔直径	15.88mm (5/8") 20mm (13/16")
Max Cutting Capacity Kapasiti Pemotongan Maksimum 最大切割能力	90°: 57mm (2-1/4") 45°: 41mm (1-5/8") 50°: 37mm (1-7/16")
No Load Speed (RPM) Kelajuan Tanpa Beban 回转数	5,000
Max Output Keluasan Maksima 最大输出	680W
Dimensions (L x W x H) Dimensi 体积	270x186x250mm (10-5/8"x7-3/8"x9-7/8")
Net Weight Berat Bersih 净重	2.9 - 3.2kg (6.4 - 7.1lbs.)
Work Amount (approx.) Jumlah Kerja 工作量	200 pcs with BL1850B Sawing with EFFICUT blade, 90° cut SPF 2 x 10 (Thickness 38mm, Width 89mm)

DHS680RMJ | DHS680RFJ | DHS680Z 165mm (6-1/2")

Cordless Circular Saw

Gergaji Piring Tanpa Kord
充电式圆锯



Opposite Handling
Cut left side of material



- High-efficiency BL motor provides higher power

Standard Equipment: TCT Saw Blade (B-63018), Hex Wrench, Rip Fence (Guide Rule)

- RMJ: 1x Rapid Charger, 2x 4.0Ah Battery, 1x Makpac Connector Box
- RFJ: 1x Rapid Charger, 2x 3.0Ah Battery, 1x Makpac Connector Box
- Z: Without Charger, Battery & Carrying Case



VIDEO CLIP
Models and specs may vary by country



Blade Diameter Diameter Bilah 锯片直径	165mm (6-1/2")
Max Cutting Capacity Kapasiti Pemotongan Maksimum 最大切割能力	90°: 57mm (2-1/4") 45°: 41mm (1-5/8") 50°: 37mm (1-7/16")
No Load Speed (RPM) Kelajuan Tanpa Beban 回转数	5,000
Dimensions (L x W x H) Dimensi 体积	350x170x238mm (13-3/4"x6-11/16"x9-3/8")
Net weight Berat Bersih 净重	3.0 - 3.3kg (6.6 - 7.3lbs)
Work Amount (approx.) Jumlah Kerja 工作量	170 pcs with BL1850B Sawing with Standard Blade, 90° cut SPF 2 x 10 (Thickness 38mm, Width 89mm)

DHS630RFE | DHS630Z 165mm (6-1/2") 441 mm

Cordless Circular Saw

Gergaji Piring Tanpa Kord
充电式圆锯



- Cut up to 66mm thick wood with a single stroke

Standard Equipment: TCT Saw Blade (D-51079), Hex Wrench, Rip Fence (Guide Rule)

- RFE: 1x Rapid Charger, 2x 3.0Ah Battery
- Z: Without Charger, Battery & Carrying Case



Blade Diameter Diameter Bilah 锯片直径	165mm (6-1/2")
Max Cutting Capacity Kapasiti Pemotongan Maksimum 最大切割能力	90°: 66mm (2-5/8") 45°: 46mm (1-13/16")
No Load Speed (RPM) Kelajuan Tanpa Beban 回转数	3,100
Dimensions (L x W x H) Dimensi 体积	346x220x247mm (13-5/8"x8-5/8"x9-3/4")
Net weight Berat Bersih 净重	3.0 - 3.4kg (6.6 - 7.5lbs)
Work Amount (approx.) Jumlah Kerja 工作量	260 pcs with BL1850B Sawing (Mixed Wood 2" x 2")



* All list price shown are for reference only (exclude SST).

* Semua harga yang ditunjukkan adalah untuk rujukan sahaja (tidak termasuk SST). 所有显示的建议零售价仅供参考 (不包括SST)。

Cordless
Tanpa Kord / 无线

LED Flashlight
Lampu Suhu LED
LED手电筒

Vacuum Cleaner
Pembersih Vakuum
吸尘器

Drilling / Fastening
Ganuli / Pasang
钻孔 / 紧固

Impact Drilling / Demolition
Ganuli / Persekit
石工钻孔 / 摧毁施工

Cutting
Panas
切割

Grinding / Sanding
Pergasi / Pasah
研磨 / 砂磨

Sawing
Gergaji
锯切

Planing / Routing
Pergasi / Tumpang
刨削 / 压花

Others
Lain-lain
其他

Outdoor Power Equipment
Alatan Kuasa Luar
园机 / 户外



Li-ion Ah 6.0 | 5.0 | 4.0 | 3.0 | 2.0 | 1.5

DJR187RME | DJR187RFE | DJR187Z

Cordless Recipro Saw
Gergaji Resipro Tanpa Kord
充电式往复锯



- BL Brushless DC motor with high power

Standard Equipment: Recipro Saw Blades 2pcs (B-05175 & B-05169)

- RME: 1x Rapid Charger, 2x 4.0Ah Battery
- RFE: 1x Rapid Charger, 2x 3.0Ah Battery
- Z: Without Charger, Battery & Carrying Case



Length of Stroke Panjang Strok 冲程长度	32mm (1-1/4")
Strokes Per Minute (SPM) Kelajuan Strok 冲程速度	High: 0 - 3,000 Low: 0 - 2,300
Capacity Kapasiti 能力	Pipe: 130mm (5-1/8") Wood: 255mm (10")
Dimensions (L x W x H) Dimensi 体积	439x83x231mm (17-1/4"x3-1/4"x9-1/8")
Net Weight Berat Bersih 淨重	3.4 - 3.8kg (7.6 - 8.3lbs)
Work Amount (approx.) Jumlah Kerja 工作量	65 pcs with BL1850B Cutting (Steel Pipe Ø34 x 3mm)

DJR188Z

Cordless Recipro Saw
Gergaji Resipro Tanpa Kord
充电式往复锯



- High cutting speed (Max 3,000 SPM) provide higher cutting efficiency

Standard Equipment:
Recipro Saw Blades 2pcs (B-20432 & B-20404)

- Z: Without Charger & Battery



Length of Stroke Panjang Strok 冲程长度	20mm (13/16")
Strokes Per Minute (SPM) Kelajuan Strok 冲程速度	0 - 3,000
Capacity Kapasiti 能力	Pipe : 130mm (5-1/8") Wood: 255mm (10")
Dimensions (L x W x H) Dimensi 体积	BL1815N: 316x81x203mm (12-1/2"x3-3/16"x8") BL1850B: 316x81x220mm (12-1/2"x3-3/16"x8-5/8")
Net Weight Berat Bersih 淨重	2.6 - 2.9kg (5.7 - 6.4lbs)
Work Amount (approx.) Jumlah Kerja 工作量	58 pcs with BL1850B Cutting (Steel Pipe Ø34 x 3mm)

DJR186RME | DJR186RFE | DJR186Z

441

Cordless Recipro Saw
Gergaji Resipro Tanpa Kord
充电式往复锯



- Toolless blade change; redesign of blade clamp makes it easier to remove a blade

Standard Equipment:
Recipro Saw Blades 2pcs (B-05175 & B-05169)

- RME: 1x Rapid Charger, 2x 4.0Ah Battery
- RFE: 1x Rapid Charger, 2x 3.0Ah Battery
- Z: Without Charger, Battery & Carrying Case

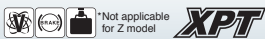

Length of Stroke Panjang Strok 冲程长度	32mm (1-1/4")
Strokes Per Minute (SPM) Kelajuan Strok 冲程速度	0 - 2,800
Capacity Kapasiti 能力	Pipe : 130mm (5-1/8") Wood: 255mm (10")
Dimensions (L x W x H) Dimensi 体积	486x81x223mm (19-1/8"x3-3/16"x8-3/4")
Net Weight Berat Bersih 淨重	3.5 - 3.8kg (7.6 - 8.3lbs)
Work Amount (approx.) Jumlah Kerja 工作量	60 pcs with BL1850B Cutting (Steel Pipe Ø34 x 3mm)

DJR181RFE

441

Cordless Recipro Saw
Gergaji Resipro Tanpa Kord
充电式往复锯



- Toolless blade change system enables fast, one-handed blade changes

Standard Equipment: Recipro Saw Blade

- RFE: 1x Rapid Charger, 2x 3.0Ah Battery



Length of Stroke Panjang Strok 冲程长度	28mm (1-1/8")
Strokes Per Minute (SPM) Kelajuan Strok 冲程速度	0 - 2,900
Capacity Kapasiti 能力	Pipe : 130mm (5-1/8") Wood: 255mm (10")
Dimensions (L x W x H) Dimensi 体积	499x91x234mm (19-5/8"x3-5/8"x9-1/4")
Net Weight Berat Bersih 淨重	3.5kg (7.7lbs)
Work Amount (approx.) Jumlah Kerja 工作量	70 pcs with BL1850B Cutting (SPF Material 2x10")

DJR183Z

Cordless Recipro Saw
Gergaji Resipro Tanpa Kord
充电式往复锯



- Dual-position on/off switch allows for either paddle or trigger switch operation

Standard Equipment: Recipro Saw Blades 2pcs

- Z: Without Charger & Battery



Capacity Panjang Strok 冲程长度	Pipe : 50mm (2") Wood: 50mm (2")
Length of Stroke Kelajuan Strok 冲程速度	13mm (1/2")
Strokes Per Minute (SPM) Kapasiti 能力	0-3,000
Dimensions (L x W x H) Dimensi 体积	392x81x209mm (15-1/2"x3-3/16"x8-1/4")
Net weight Berat Bersih 淨重	1.5 - 1.7kg (3.3 - 3.8lbs)
Work Amount (approx.) Jumlah Kerja 工作量	56 pcs with BL1850B Cutting (SPF Material 2x10")

* All list price shown are for reference only (exclude SST).

* Semua harga yang ditunjukkan adalah untuk rujukan sahaja (tidak termasuk SST). 所有显示的建议零售价仅供参考 (不包括SST)。

Cordless Target Kord 无绳
LED Flashlight Lampu Suluh LED LED 照明灯
Vacuum Cleaner Pembersih Vakuum 吸尘器
Drilling / Fastening Bor / Pasang 钻孔 / 紧固
Impact Drilling / Demolition Bor / Perseki 起工 钻孔 / 拆除加工
Cutting Pemotong 切割
Grinding / Sanding Pengisar / Pasir 打磨 / 砂磨
Sawing Gergaji 电锯
Planing / Routing Pengisar / Tampat 刨削 / 雕刻
Others Lain-lain 其他
Outdoor Power Equipment Alatan Kerja Luar 户外户外





Li-ion Ah 6.0 5.0 4.0 3.0 2.0 1.5

DJV184RFJ | DJV184Z

Cordless Jig Saw
Gergaji Jig Tanpa Kord
充电式线锯机



Li-ion Ah 6.0 5.0 4.0 3.0 2.0 1.5

18V



- High cutting performance, compact and lightweight for reduced operator fatigue

Standard Equipment: Jig Saw Blade (B-50), Hex Wrench, Cover Plate

- RFJ: 1x Rapid Charger, 2x 3.0Ah Battery, 1x Makpac Connector Box
- Z: Without Charger, Battery & Carrying Case



Capacity Kapasiti 能力	Wood: 135mm (5-5/16") Mild steel: 10mm (3/8") Aluminum: 20mm (25/32")
Length of Stroke Panjang Strok 冲程长度	23mm (7/8")
Strokes Per Minute (SPM) Kelajuan Strok 冲程速度	0 - 3,000
Dimensions (L x W x H) Dimensi 体积	259x77x205mm (10-1/4x3x8-1/8")
Net Weight Berat Bersih 净重	2.1 - 2.4kg (4.6 - 5.3lbs.)
Work Amount (approx.) Jumlah Kerja 工作量	165 pcs with BL1860B Sawing with Blade B-10 with Max Orbital mode MDF (Thickness 24mm x Width 300mm)

DJV182RME | DJV182RFE | DJV182Z

Cordless Jig Saw
Gergaji Jig Tanpa Kord
充电式线锯机



- Powerful Brushless DC motor

Standard Equipment: Jig Saw Blade Set (No. BR-10, BR-13, B-22, 2pcs each), Cover Plate, Anti-Splintering Device, Hex Wrench

- RME: 1x Rapid Charger, 2x 4.0Ah Battery
- RFE: 1x Rapid Charger, 2x 3.0Ah Battery
- Z: Without Charger, Battery & Carrying Case



Capacity Kapasiti 能力	Wood: 135mm (5-5/16") Steel: 10mm (3/8") 26mm (1")
Length of Stroke Panjang Strok 冲程长度	26mm (1")
Strokes Per Minute (SPM) Kelajuan Strok 冲程速度	800 - 3,500
Dimensions (L x W x H) Dimensi 体积	266x77x208mm (10-1/2"x3"x8-3/16")
Net Weight Berat Bersih 净重	2.4 - 2.7kg (5.2 - 5.9lbs)
Work Amount (approx.) Jumlah Kerja 工作量	266 pcs with BL1850B Sawing with Blade B-10 Plywood (Thickness 12mm x Length 300mm)



DJV181/DJV182 Models and specs may vary by country

DJV181RFE | DJV181Z

Cordless Jig Saw
Gergaji Jig Tanpa Kord
充电式线锯机



- Excellent performance provides higher productivity

Standard Equipment: Jig Saw Blade Set (No. BR-10, BR-13, B-22, 2pcs each), Cover Plate, Anti-Splintering Device, Hex Wrench

- RFE: 1x Rapid Charger, 2x 3.0Ah Battery
- Z: Without Charger, Battery & Carrying Case



Capacity Kapasiti 能力	Wood: 135mm (5-5/16") Steel: 10mm (3/8") 26mm (1")
Length of Stroke Panjang Strok 冲程长度	26mm (1")
Strokes Per Minute (SPM) Kelajuan Strok 冲程速度	800 - 3,500
Dimensions (L x W x H) Dimensi 体积	298x77x189mm (11-3/4"x3"x7-7/16")
Net Weight Berat Bersih 净重	2.3 - 2.6kg (5.0 - 5.7lbs)
Work Amount (approx.) Jumlah Kerja 工作量	266 pcs with BL1850B Sawing with Blade B-10 Plywood (Thickness 12mm x Length 300mm)



DJV181/DJV182 Models and specs may vary by country

DJV180RFE | DJV180Z

440mm

Cordless Jig Saw
Gergaji Jig Tanpa Kord
充电式线锯机



- Low vibration and low noise

Standard Equipment: Jig Saw Blade Set (No. BR-10, BR-13, B-22, 2pcs each), Cover Plate, Anti-Splintering Device, Hex Wrench

- RFE: 1x Rapid Charger, 2x 3.0Ah Battery
- Z: Without Charger, Battery & Carrying Case



Capacity Kapasiti 能力	Wood: 135mm (5-5/16") Steel: 10mm (3/8") 26mm (1")
Length of Stroke Panjang Strok 冲程长度	26mm (1")
Strokes Per Minute (SPM) Kelajuan Strok 冲程速度	0-2,600
Dimensions (L x W x H) Dimensi 体积	257x73x208mm (10-1/8"x2-7/8"x8-3/16")
Net Weight Berat Bersih 净重	2.7 - 3.0kg (6.0 - 6.7lbs)
Work Amount (approx.) Jumlah Kerja 工作量	216 pcs with BL1850B Sawing with Blade B-10 Plywood (Thickness 12mm x Length 300mm)

DSD180Z

Cordless Drywall Saw
Gergaji Drywall Tanpa Kord
充电式石膏板切割机



- Ideal for cutting holes in drywalls when setting ceiling lights, air vents etc

Standard Equipment: Blade, Blade Cover, Base Cover, Hex Wrench

- Z: Without Charger & Battery



Strokes Per Minute (SPM) Kelajuan Strok 冲程速度	0 - 6,000
Length of Stroke Panjang Strok 冲程长度	6mm (1/4")
Capacity Kapasiti 能力	Drywall: 30mm (1-3/16") Wood: 15mm (9/16")
Dimensions (L x W x H) Dimensi 体积	263x79x291mm (10-3/8"x3-1/8"x11-3/8")
Net weight Berat Bersih 净重	1.7 - 2.0kg (3.8 - 4.5lbs)
Work Amount (approx.) Jumlah Kerja 工作量	360 m with BL1850B Cutting (Gypsum Board Thickness 12.5mm/ 1ply)



DSD180 Models and specs may vary by country

* All list price shown are for reference only (exclude SST).

* Semua harga yang ditunjukkan adalah untuk rujukan sahaja (tidak termasuk SST). 所有显示的建议零售价仅供参考 (不包括SST)。

Cordless
Targeted Jobs

LED Flashlight
Lampu Saku LED
LED手电筒

Vacuum Cleaner
Pembersih Vakum
吸尘器

Drilling / Fastening
Gergaji / Pengikat
钻孔 / 紧固

Impact Drilling / Demolition
Gerudi / Penusuk
石工钻孔 / 砸墙施工

Cutting
Pemotong
切割

Grinding / Sanding
Pengkilan / Pemoles
打磨 / 砂磨

Sawing
Gergaji
锯切

Planing / Routing
Pengkilan / Tumpang
刨削 / 压花

Others
Lain-lain
其他

Outdoor Power Equipment
Alatan Kerja Luar
园机 / 户外

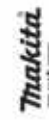



Li-ion Ah 6.0 5.0 4.0 3.0 2.0 1.5

DPJ180Z

430 mm

Cordless Plate Joiner
Mesin Kayu Tanpa Kord
充电式木工接合机

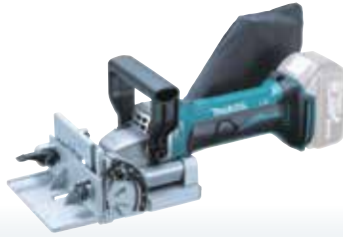

- Easy blade setting system for fast blade installation

Standard Equipment: Cutter Blade, Angle Guide, Lock Nut Wrench, Set Plate, Dust Bag

- Z: Without Charger & Battery



Blade Diameter Diameter Bilah 锯片直径	100mm (4")
Max Cutting Depth Kedalaman Pemotongan Maksimum 最大切割深度	20mm (3/4")
No Load Speed (RPM) Kelajuan Tanpa Beban 回转数	6,500
Dimensions (L x W x H) Dimensi 体积	351x139x149mm (13-3/4"x5-1/2"x5-7/8")
Net weight Berat Bersih 净重	2.8 - 3.1kg (6.2 - 6.8lbs)
Work Amount (approx.) Jumlah Kerja 工作量	333 pcs with BL1850B Biscuit (60 x 23 x 4) Cutting Slot 12.3mm

DKP181RTJ | DKP181Z 82mm (3-1/4")

Cordless Planer
Pengetam Tanpa Kord
充电式电刨



- Auto-start Wireless System (AWS) connects to vacuum cleaner with Bluetooth

Standard Equipment: Planer Blade, Blade Gauge, Guide Rule, Depth Guide, Socket Wrench, Sharpening Holder Assembly (for resharpenable blade)

- RTJ: 1x Rapid Charger, 2x 5.0Ah Battery, 1x Makpac Connector Box
- Z: Without Charger, Battery & Carrying Case



Planing Width Lebar Pelan 刨削宽度	82mm (3-1/4")
Planing Depth Kedalaman Pelan 刨削深度	3mm (1/8")
No Load Speed (RPM) Kelajuan Tanpa Beban 回转数	12,000
Dimensions (L x W x H) Dimensi 体积	366x156x166mm (14-3/8"x6-1/8"x6-1/2")
Net Weight Berat Bersih 净重	3.3 - 3.6kg (7.3 - 7.9lbs.)
Work Amount (approx.) Jumlah Kerja 工作量	46 m with BL1850B 67mm wide x 1,000mm (Douglas fir) (depth 2.0mm)



DKP180RFE | DKP180Z 82mm (3-1/4")

441 mm

Cordless Planer
Pengetam Tanpa Kord
充电式电刨



- Easy blade setting system for fast blade installation

Standard Equipment: Planer Blade, Blade Gauge, Guide Rule, Socket Wrench

- RFE: 1x Rapid Charger, 2x 3.0Ah Battery
- Z: Without Charger, Battery & Carrying Case



Planing Width Lebar Pelan 刨削宽度	82mm (3-1/4")
Planing Depth Kedalaman Pelan 刨削深度	2.0mm (5/64")
No Load Speed (RPM) Kelajuan Tanpa Beban 回转数	14,000
Dimensions (L x W x H) Dimensi 体积	333x157x160mm (13-1/8"x6-3/16"x6-5/16")
Net weight Berat Bersih 净重	3.2 - 3.5kg (7.1 - 7.9lbs)
Work Amount (approx.) Jumlah Kerja 工作量	91 m with BL1850B Wood Thickness 1mm

DGP180RT | DGP180Z

Cordless Grease Gun
Alat Tembak Gris Tanpa Kord
充电式黄油枪



- Mainly for maintenance jobs of heavy machinery, farm machinery or other large machinery, such as greasing up, crawler track tensioning and more

Standard Equipment: Shoulder Strap

- RT: 1x Rapid Charger, 1x 5.0Ah Battery
- Z: Without Charger, Battery & Carrying Case



Flow Rate Kadar Aliran 流量	Auto Speed Change Mode: 290mL/min (10.0oz/min) Slow Speed Mode: 145mL/min (5.0oz/min)
Grease Capacity w/ Barrel A	Cartridge: 410g (14.5oz) Bulk: 455g (16.0oz)
Grease Capacity w/ Barrel B	Cartridge: 450g (15.9oz) Bulk: 570g (20.1oz)
Grease Capacity w/ Barrel C	Cartridge: 500g (17.6oz) Bulk: 570g (20.1oz)
Hose Length Panjang Hos 软管长度	120cm (47-1/4")
Max Operating Pressure Tekanan Beroperasi Maksimum 最大使用气压	69MPa (10000PSI)
Dimensions (L x W x H) Dimensi 体积	411x114x245mm (16-1/4x4-1/2x9-5/8")
Net Weight Berat Bersih 净重	4.8 - 6.1kg (10.6 - 13.4lbs.)
Work Amount (approx.) Jumlah Kerja 工作量	2,356mL Dispensing (Operating pressure 60MPa at low speed range)

DCO181Z 6.35mm (1/4")

Cordless Cut-Out Tool
Mesin Pemotong Tanpa Kord
充电式石膏板开孔机



- Auto-start Wireless System (AWS) connects to compatible vacuum cleaners with Bluetooth

Standard Equipment: Drywall Guide Bit x2, Collet Cone, Dust Collection Cover, Wrench

- Z: Without Charger & Battery



Collet Capacity Kapasiti Collet 夹头直径	3mm (1/8") 6mm (1/4")
No Load Speed (RPM) Kelajuan Tanpa Beban 回转数	32,000
Circumference of Grip Portion Lingkaran Pemegang 握把周长	210mm (8-1/4")
Dimensions (L x W x H) Dimensi 体积	311x79x117mm (12-1/4x3-1/8x4-5/8")
Net Weight Berat Bersih 净重	1.4 - 1.7kg (3.1 - 3.7lbs.)
Work Amount (approx.) Jumlah Kerja 工作量	Up to 32 cuts for a drywall of 1/2 inch (12.7mm) thickness with cutting length of 910mm using drywall guide tip bit 6.35mm with BL1830B



* All list price shown are for reference only (exclude SST).

* Semua harga yang ditunjukkan adalah untuk rujukan sahaja (tidak termasuk SST). 所有显示的建议零售价仅供参考 (不包括SST)。

Cordless
Tanpa Kord 无绳式

LED Flashlight
Lampu Suluh LED
LED 手电筒

Vacuum Cleaner
Pembersih Vakuum
吸尘器

Drilling / Fastening
Mandi / Pengetam
钻孔 / 紧固

Impact Drilling / Demolition
Ganda / Penanggal
起工钻孔 / 拆墙加工

Cutting
Pemotong
切割

Grinding / Sanding
Pengisar / Pencil
磨削 / 砂磨

Sawing
Ganda
锯切

Planing / Routing
Pengetam / Tangkapan
刨削 / 刨削

Others
Lain-lain
其他

Outdoor Power Equipment
Alatan Kerja Luar
园机-户外





Li-ion Ah 6.0 5.0 4.0 3.0 2.0 1.5

DCO180Z 6.35mm (1/4")

430mm

Cordless Cut-Out Tool
Mesin Pemotong Tanpa Kord
充电式石膏板开孔机



- Accepts both 1/8" and 1/4" bits

Standard Equipment: Drywall Guide Bit x2, Collet Nut, Collet Cone 6.35mm (1/4")

- Z: Without Charger & Battery



DVP181ZK

Cordless Vacuum Pump
Pam Vakum Tanpa Kord
充电式真空泵



- High power for 20 HP professional-use refrigeration case and large air conditioner



Standard Equipment: Vacuum Pump Oil, Adapter

- ZK: With Carrying Case, Without Charger & Battery



DVP180Z

Cordless Vacuum Pump
Pam Vakum Tanpa Kord
充电式真空泵



- For air purge during installation of room air conditioner

Standard Equipment: Vacuum Pump Oil, Adapter

- Z: Without Charger & Battery

DRT50Z | DRT50ZJX9 6mm (1/4"), 8mm (3/8")

Cordless Trimmer
Mesin Perapi Tanpa Kord
充电式修边机



- Faster Trimming than Corded

Standard Equipment: Trimmer Base Assembly (196612-6), Collet Cone, Dust Nozzle, Straight Guide Assembly, Wrench x2

- Z : Without Charger, Battery & Carrying Case
- ZJX9: Tilt Base Assembly (195561-4), Plunge Base Assembly (195563-0), Side Grip, Template Guide, Guide Rail Adapter Set, Guide Holder Set, Makpac Connector Box, Without Charger & Battery



Capacity Kapasiti 能力	Collet : 3.18mm (1/8") or 6.35mm (1/4")
No Load Speed (RPM) Kelajuan Tanpa Beban 回转数	30,000
Dimensions (L x W x H) Dimensi 体积	296x77x118mm (11-5/8"x3"x4-5/8")
Net weight Berat Bersih 净重	1.5 - 1.8kg (3.3 - 4.0lbs)
Work Amount (approx.) Jumlah Kerja 工作量	225 m with BL1850B 6.35mm Bit Cutting Plaster Board 1.2 x 800mm

Flow Rate Kadar Aliran 流量	113L/min
Motor Speed Kelajuan Motor 马达速度	3,200min ⁻¹
Oil Tank Capacity Kapasiti Tangki Minyak 润滑油箱	300mL
Inlet Port Pelabuhan Inlet 进气管直径	5/16" 3/8"
Dimensions (L x W x H) Dimensi 体积	383x193x210mm (15-1/8"x7-5/8"x8-1/4")
Net Weight Berat Bersih 净重	8.1 - 8.2kg (17.9 - 18.1lbs.)
Continuous Usage Time (approx.) Masa Penggunaan Berterusan 连续使用时间	60 min with BL1860B x2

Flow Rate Kadar Aliran 流量	50L/min
Ultimate Vacuum Tahap Maksimum Vakum 最大真空度	20Pa (150 microns)
Motor Speed Kelajuan Motor 马达速度	3,840min ⁻¹
Oil Tank Capacity Kapasiti Tangki Minyak 润滑油箱	115mL
Inlet Port Pelabuhan Inlet 进气管直径	5/16"
Dimensions (L x W x H) Dimensi 体积	265x93x175mm (10-3/8"x3-5/8"x6-7/8")
Net Weight Berat Bersih 净重	3.5kg
Continuous Usage Time (approx.) Masa Penggunaan Berterusan 连续使用时间	50 min with BL1850B

Collet Capacity Kapasiti Collet 夹头直径	6mm, 8mm or 1/4", 3/8"
No Load Speed (RPM) Kelajuan Tanpa Beban 回转数	10,000 - 30,000
Plunge Capacity Kapasiti Plunge 能力	Trimmer Base: 0 - 40mm (0" - 1-9/16") Plunge Base: 0 - 35mm (0" - 1-3/8")
Dimensions (L x W x H) Dimensi 体积	134x89x226mm (5-1/4"x3-1/2"x8-7/8")
Net Weight Berat Bersih 净重	1.8 - 2.1kg (3.9 - 4.6lbs)
Work Amount (approx.) Jumlah Kerja 工作量	83 m with BL1850B Routing Ø6 x 4mm



Trimmer Base Assembly (Optional)

Trimmer Base
Part No. 196612-6



Plunge Base
Part No. 195563-0 (Optional)



Tilt Base
Part No. 195561-4 (Optional)



Offset Base
Part No. 196922-1 (Optional)

* All list price shown are for reference only (exclude SST).

* Semua harga yang ditunjukkan adalah untuk rujukan sahaja (tidak termasuk SST). 所有显示的建议零售价仅供参考 (不包括SST)。

Cordless
Target Model 30424

LED Flashlight
Lampu Suhu LED
LED照灯

Vacuum Cleaner
Pembersih Vakum
吸尘器

Drilling / Fastening
Ganuli / Pasrasah
钻孔 / 紧固

Impact Drilling / Demolition
Ganuli / Pasrasah
冲击钻孔 / 拆除施工

Cutting
Panasir
切割

Grinding / Sanding
Pengasah / Pasrah
研磨 / 砂磨

Saving / Guide
Ganuli
导引

Planing / Routing
Pengasah / Tanggam
刨削 / 压花

Others
Lain-lain
其他

Outdoor Power Equipment
Alatan Kuasa Luar
园机 / 户外

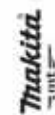



Li-ion Ah 6.0 5.0 4.0 3.0 2.0 1.5

DFN350Z

Cordless Brad Nailer
Mesin Pemaku Tanpa Kord
充电式打钉机



- Ideal for Light Duty Applications such as Fastening Chamfer Strip to Concrete Form Plywood Wall

Standard Equipment: Safety Goggles (195246-2), Nose Adapter, Hex Wrench, Belt Clip

• Z : Without Charger & Battery



Capacity Kapasiti 能力	Length: 15 - 35mm (5/8" - 1-3/8")
Magazine Capacity Bilangan Staples 装订个数	Gauge: 18Ga 110
Dimensions (L x W x H) Dimensi 体积	257x79x228mm (10-1/8"x3-1/8"x9")
Net Weight Berat Bersih 淨重	2.1 - 2.4kg (4.6 - 5.3lbs.)
Work Amount (approx.) Jumlah Kerja 工作量	4000pcs with BL1850B

Accessories (optional)			
Description	Size	Pcs/ Box	Part No.
Brad Nail 15mm (5/8")	F15	5,000	B-04307
Brad Nail 20mm (3/4")	F20	5,000	B-04313
Brad Nail 25mm (1")	F25	5,000	B-04329
Brad Nail 30mm (1-3/16")	F30	5,000	B-04335
Brad Nail 35mm (1-3/8")	F35	5,000	B-04357

DPT353Z

Cordless Pin Nailer
Mesin Pemaku Tanpa Kord
充电式打钉机



- Shoots 6,400 nails on a single full BL1860B charge

Standard Equipment: Nose Adapter, Safety Goggles (195246-2), Belt Clip

• Z : Without Charger & Battery



Capacity Staple 钉种	Length: 15, 18, 25, 30, 35mm (5/8", 11/16", 1", 1-3/16", 1-3/8")
Magazine Capacity Bilangan Staples 装订个数	Dia.: 0.6mm (1/32") Gauge: 23Ga 120
Dimensions (L x W x H) Dimensi 体积	257x79x226mm (10-1/8"x3-1/8"x8-7/8")
Net Weight Berat Bersih 淨重	2.0 - 2.3kg (4.4 - 5.1 lbs)
Work Amount (approx.) Jumlah Kerja 工作量	5300 pcs Pin Nail with BL1850B

Accessories (optional)			
Description	Size	Pcs/ Box	Part No.
Pin Nail 18mm (11/16")	P18	10,000	F-31825
Pin Nail 25mm (1")	P25	10,000	F-31838
Pin Nail 30mm (1-3/16")	P30	10,000	F-31841
Pin Nail 35mm (1-3/8")	P35	10,000	F-31854

DST121ZK

Cordless Stapler
Stapler Tanpa Kord
充电式钉枪

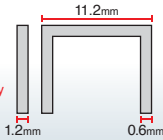

- Contact arm mechanism enables "continuous nailing" and "drag nailing"

Standard Equipment: Safety Goggles (195246-2), Nose Adapter, Belt Clip

• ZK: With Carrying Case, Without Charger & Battery



Staple Staple 钉种	Width: 10mm (3/8") Length: 13 - 25mm (1/2 - 1")
Magazine Capacity Bilangan Staples 装订个数	Size: 1.2 x 0.6mm 100
Dimensions (L x W x H) Dimensi 体积	260x79x216mm (10-1/4x3-1/8x8-1/2")
Net Weight Berat Bersih 淨重	2.2 - 2.5kg (4.9 - 5.5lbs.)
Work Amount (approx.) Jumlah Kerja 工作量	4000 pcs with BL1850B

Accessories (optional)		
Description	Length	Part No.
Staple 1010J	10mm	B-04466
Staple 1013J	13mm	B-04472
Staple 1016J	16mm	B-04488
Staple 1019J	19mm	B-04494
Staple 1022J	22mm	B-04503
Staple 1025J	25mm	B-04519

DST221Z

Cordless Stapler
Stapler Tanpa Kord
充电式钉枪

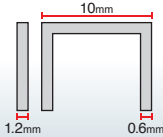

- Compact and powerful stapler can drive a wide range of 10mm staple lengths

Standard Equipment: Safety Goggles (195246-2), Hook

• Z : Without Charger & Battery



Staple Staple 钉种	Width: 10mm (3/8") Length: 10, 13, 16, 19, 22mm (3/8", 1/2", 5/8", 3/4", 7/8")
Magazine Capacity Bilangan Staples 装订个数	Gauge: 0.6 x 1.2mm (1/32" x 1/16") 98
Dimensions (L x W x H) Dimensi 体积	251x91x212mm (9-7/8"x3-5/8"x8-3/8")
Net Weight Berat Bersih 淨重	2.1 - 2.4kg (4.7 - 5.3lbs)
Work Amount (approx.) Jumlah Kerja 工作量	3000 pcs with BL1850B Stapler Width 10mm

Accessories (optional)			
Description	Length	Pcs/ Box	Part No.
Staple 1010HD	10mm (3/8")	5,040	F-32647
Staple 1013HD	13mm (1/2")	5,040	F-32650
Staple 1016HD	16mm (5/8")	5,040	F-32663
Staple 1019HD	19mm (3/4")	5,040	F-32676
Staple 1022HD	22mm (7/8")	5,040	F-32689

DST421ZK

Cordless Stapler
Stapler Tanpa Kord
充电式钉枪

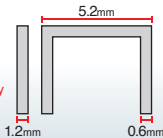

- Contact arm mechanism enables "continuous nailing" and "drag nailing"

Standard Equipment: Safety Goggles (195246-2), Nose Adapter, Belt Clip

• ZK: With Carrying Case, Without Charger & Battery



Staple Staple 钉种	Width: 4mm Length: 13 - 25mm (1/2 - 1")
Magazine Capacity Bilangan Staples 装订个数	Size: 1.2 x 0.6mm 100
Dimensions (L x W x H) Dimensi 体积	260x79x216mm (10-1/4x3-1/8x8-1/2")
Net Weight Berat Bersih 淨重	2.2 - 2.5kg (4.9 - 5.5lbs.)
Work Amount (approx.) Jumlah Kerja 工作量	4000 pcs with BL1850B

Accessories (optional)		
Description	Length	Part No.
Staple 410J	10mm	B-04400
Staple 413J	13mm	B-04416
Staple 416J	16mm	B-04422
Staple 419J	19mm	B-04438
Staple 422J	22mm	B-04444
Staple 425J	25mm	B-04450

* All list price shown are for reference only (exclude SST).

* Semua harga yang ditunjukkan adalah untuk rujukan sahaja (tidak termasuk SST). 所有显示的建议零售价仅供参考 (不包括SST)。

Cordless Target Kord 无绳式
LED Flashlight Lampu Suluh LED LED 照明灯
Vacuum Cleaner Pembersih Vakuum 吸尘器
Drilling / Fastening Dremel / Pengikat 钻式 / 紧固
Impact Drilling / Demolition Ganda / Penumbuh 起工钻式 / 拆墙加工
Cutting Pemotong 切割机
Grinding / Sanding Pengisar / Poles 磨削 / 打磨
Sawing Ganda 锯切
Planing / Routing Pengisar / Tangkapan 磨削 / 磨床
Others Lain-lain 其他
Outdoor Power Equipment Alatan Kerja Luar 园机-户外





Li-ion Ah 6.0 5.0 4.0 3.0 2.0 1.5

DVR450Z 1,200mm (4.0ft)

Cordless Concrete Vibrator
Penggatar Konkrit Tanpa Kord
充电式混凝土振动器



- Makita-built motor delivers 13,000VPM to help increase strength of concrete



• Z: Without Charger & Battery

Diameter of Vibrator Diameter Penggetar 振动器的直径	25mm (1")
Flexible Shaft Assembly Length Panjang Pemasangan Fleksibel 柔性轴组件长度	1,200mm (4.0 ft)
Vibrations Per Minute (VPM) Getaran Setiap Minit 每分钟振动	13,000
Dimensions (L x W x H) Dimensi 体积	1,483x93x250mm (58-1/2"x3-5/8"x9-7/8")
Net Weight Berat Bersih 净重	3.3 - 3.8kg (7.3 - 8.3lbs)
Continuous Usage Time (approx.) Masa Penggunaan Berterusan 连续使用时间	41 min with BL1850B

DCG180RFE | DCG180RFEB | DCG180ZB | DCG180Z

Cordless Caulking Gun
Pistol Caulking Tanpa Kord
充电式填缝枪



- 5 Speed dial optimizes flow rate 0 - 28mm/sec

Standard Equipment:

RFE / Z: 300mL Holder A, Holder Joint A, Piston, Rack 42, Safety Goggles
RFEb / ZB: 600mL Holder B, Holder Joint B, Piston, Nozzle, Rubber Ring, Rack 64, Safety Goggles

- RFE: 1x Rapid Charger, 2x 3.0Ah Battery
- RFEb: 1x Rapid Charger, 2x 3.0Ah Battery
- ZB: Without Charger, Battery & Carrying Case
- Z: Without Charger, Battery & Carrying Case



*Not applicable for Z & ZB model

Max Dispersing Force Tujahan Maksimum 最大推力	5,000N (1,100lbs)
No Load Speed Kelajuan Tanpa Beban 回转数	0 - 28mm/sec. (0 - 66in/min.)
Holder Size Kapasiti 容量	300mL 600mL (Optional Accessories 800mL Holder)
Dimensions (L x W x H) Dimensi 体积	404x108x281mm (15-7/8"x4-1/4"x11-1/8")
Net Weight Berat Bersih 净重	2.1 - 3.0kg (4.7 - 6.6lbs)
Work Amount (approx.) Jumlah Kerja 工作量	500 pcs with BL1830B 300ml silicon sealant



VIDEO CLIP
Models and specs may vary by country

DMP181
Cordless Inflator



DMP181	Light Truck	Car	Tractor	Bicycle	Road Bike	Ball	Beach ball / Swim ring
Valve Shape							
Adapter		American 		British 	French 	For Balls 	For Swim rings/ Beach balls
Objects Conditions	Size: 205/70R16 0→600kPa High speed mode	Size: 215/60R16 0→250kPa High speed mode	Size: 7-14 0→180kPa High speed mode	Size: 26 inch 0→300kPa Low speed mode	Size: 700x23C 0→700kPa High speed mode	Size: 700x23C 0→90kPa Ball mode	Size: 30cm High speed mode
Work Speed (approx)	9 min 40 sec	3 min 30 sec	1 min 50 sec	9 sec	18 sec	39 sec	25 sec
Work Amount Battery BL1860B	3 times	14 times	25 times	500 times	110 times	230 times	120 times

DMP181Z

Cordless Inflator
Inflator Tanpa Kord
充电式打气机



- Ideal for inflating tires of cars and bicycles, sport balls, and more

Standard Equipment:

British Adapter, French Adapter, Ball Adapter, Swim Ring Adapter

- Z: Without Charger & Battery



Max Air Pressure Udara Tekanan Maksimum 最大气压	1,110kPa (161 PSI) [11.1 bar]
Air Discharge Amount Pelepasan Udara 空气排放量	200kPa: 22L/min 700kPa: 11L/min
Hose Length Panjang Hos 软管长度	65cm (25-1/2")
Dimensions (L x W x H) Dimensi 体积	316x108x231mm (12-1/2"x4-1/4"x9-1/8")
Net Weight Berat Bersih 净重	2.5 - 2.8kg (5.5 - 6.2lbs.)
Work Amount (approx.) Jumlah Kerja 工作量	14 times with BL1860B (16" Car Tires 215/60R16)

DMP180Z

Cordless Inflator
Inflator Tanpa Kord
充电式打气机



- Inflates the Tires of Cars, Bikes, Sport Balls, etc

Standard Equipment: British Adapter, French Adapter, Ball Adapter, Swim Ring Adapter

- Z: Without Charger & Battery



Max Air Pressure Udara Tekanan Maksimum 最大气压	830kPa (121 PSI) [8.3 bar]
Air Discharge Amount Pelepasan Udara 空气排放量	200kPa: 12L/min 700kPa: 8L/min 830kPa: 7L/min
Hose Length Panjang Hos 软管长度	65cm (25-1/2")
Dimensions (L x W x H) Dimensi 体积	246x80x174mm (9-11/16"x3-1/8"x6-7/8")
Net Weight Berat Bersih 净重	1.4 - 1.7kg (3.1 - 3.8lbs.)
Work Amount (approx.) Jumlah Kerja 工作量	9 tires with BL1850B (16" Car Tires 215/60R16)



VIDEO CLIP
Models and specs may vary by country

* All list price shown are for reference only (exclude SST).

* Semua harga yang ditunjukkan adalah untuk rujukan sahaja (tidak termasuk SST). 所有显示的建议零售价仅供参考 (不包括SST)。

Cordless
Target Model 3000Z

LED Flashlight
Lampu Suhu LED
LED照灯

Vacuum Cleaner
Pembersih Vakuum
吸尘器

Drilling / Fastening
Gergaji / Pengikat
钻孔 / 紧固

Impact Drilling / Demolition
Gergaji / Pemusnah
冲击钻孔 / 拆毁动工

Cutting
Pemotong
切割

Grinding / Sanding
Pengkilat / Pasir
打磨 / 砂磨

Sanding
Gergaji
锯切

Planing / Routing
Pengkilat / Tanggapan
刨削 / 磨削

Others
Lain-lain
其他

Outdoor Power Equipment
Alatan Kerja Luar
园机 / 户外





DHG180 | DHG181 Cordless Heat Gun



Air volume sliding switch
Stage 1: 120 L/min,
Stage 2: 200 L/min

DHG181 only



Air temperature adjustment dial 1-6
from ambient temperature to 550°C

DHG181 only

Wide Variety of Accessories



Glass protection nozzle
Part No. PR00000028



Wide-slot nozzle
Part No. PR00000029



Reflector nozzle
Part No. PR00000030



Reduction nozzle 20
Part No. PR00000031



Overlap welding nozzle
(Optional)
Part No. PR00000032



Solder sleeves reflector
(Optional)
Part No. PR00000033

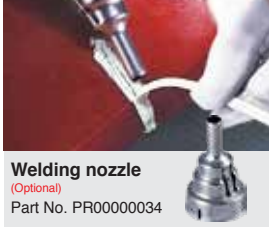

Welding nozzle
(Optional)
Part No. PR00000034



Pressure roller (Optional)
Part No. PR00000035



Scraper (Optional)
Part No. PR00000040



Scraper set (Optional)
Part No. PR00000041

Scraper (Optional)
Part No. PR00000042

DHG180ZK

Cordless Heat Gun
Pistol Udara Panas Tanpa Kord
充电式热风枪



Li-ion Ah 6.0 5.0 4.0 3.0 2.0 1.5

18V



• Max air flow of 200 L/min; Almost as powerful as Competitors' DC machines

Standard Equipment: Glass Protection Nozzle, Wide Slot Nozzle, Reflector Nozzle, Reduction Nozzle

• ZK: With Carrying Case, Without Charger & Battery



Air Temperature (°C) Suhu Udara 气温	550°C
Air Flow Aliran Udara 空气流量	200L/min
Dimensions (L x W x H) Dimensi 体积	168x79x251mm (6-5/8x3-1/8x9-7/8")
Net Weight Berat Bersih 净重	1.0 - 1.3kg (2.2 - 2.9lbs.)
Continuous Usage Time (approx.) Masa Penggunaan Berterusan 连续使用时间	21 min with BL1860B

DHG181ZK

Cordless Heat Gun
Pistol Udara Panas Tanpa Kord
充电式热风枪



Li-ion Ah 6.0 5.0 4.0 3.0 2.0 1.5

18V



• Max air flow of 200 L/min; Almost as powerful as Competitors' DC machines
• Max 550°C air temperature for a wide range of application

Standard Equipment: Glass Protection Nozzle, Wide Slot Nozzle, Reflector Nozzle, Reduction Nozzle 20

• ZK: With Carrying Case, Without Charger & Battery



Air Temperature (°C) Suhu Udara 气温	Dial 1: Ambient temperature Dial 2: 150°C Dial 3: 250°C Dial 4: 350°C Dial 5: 450°C Dial 6: 550°C
Air Flow Aliran Udara 空气流量	Stage 1: 120 L/min Stage 2: 200 L/min
Dimensions (L x W x H) Dimensi 体积	173x79x255mm (6-3/16x3-1/8x10")
Net Weight Berat Bersih 净重	1.0 - 1.4kg (2.2 - 3.1lbs.)
Continuous Usage Time (approx.) Masa Penggunaan Berterusan 连续使用时间	Stage 1: 30 min Stage 2: 21 min with BL1860B

* All list price shown are for reference only (exclude SST).

* Semua harga yang ditunjukkan adalah untuk rujukan sahaja (tidak termasuk SST). 所有显示的建议零售价仅供参考 (不包括SST)。

Cordless
Target Kord 无绳式

LED Flashlight
Lampu Suluh LED
LED 闪光灯

Vacuum Cleaner
Pembersih Vakuum
吸尘器

Drilling | Fastening
Druksi | Pasang
钻孔 | 紧固

Impact Drilling | Demolition
Druksi | Hancurkan
冲击钻孔 | 拆除加工

Cutting
Pemotong
切割

Grinding | Sanding
Pengamir | Pasir
打磨 | 砂磨

Sawing
Gergaji
锯切

Planing | Routing
Pengamir | Tampam
刨削 | 雕刻

Others
Lain-lain
其他

Outdoor Power Equipment
Alatan Kord Luar
园机-户外





Li-ion Ah 6.0 5.0 4.0 3.0 2.0 1.5

DUR194SFX1 | DUR194ZX1

Cordless Grass Trimmer
Pemotong Rumput Tanpa Kord
充电式割草机



- Speed Change Switch for easy high/ low speed selection

Standard Equipment: Safety Goggles (195246-2), Shoulder Belt, Metal Blade, Hex Wrench, Box Driver, Accessory Bag, Tool Cover

- SFX1: 1x Standard Charger, 1x 3.0Ah Battery
- ZX1: Without Charger & Battery



Max Output Keluaran Maksima 最大输出	230W
Cutting Width Lebar Keratan 切割宽度	Metal Blade: 200mm (7-7/8") Plastic Blade: 230mm (9") Trimmer Head: 280mm (11")
No Load Speed (RPM) Kelajuan Tanpa Beban 回转速数	High: 6,000 Low: 4,500
Spindle Size Saiz Spinde 主轴尺寸	M10 x 1.25LH
Dimensions (L x W x H) Dimensi 体积	1,580x288x236mm (62-1/4x11-3/8x9-1/4")
Net Weight Berat Bersih 淨重	2.6 - 2.9kg (5.7 - 6.4lbs.)
Continuous Usage Time (approx.) Masa Penggunaan Berterusan 连续使用时间	High: 32 min Low: 61 min with BL1860B Plastic blade with load

DUR193 Cordless Grass Trimmer



Continuous Usage Time with BL1830B
Nylon cutting head with load

25 min
(approx.)

Cutting Width 260mm

ø1.65mm four-leaf nylon cord

30% improvement in nylon cord durability



Telescopic shaft pipe

- Well balanced design with fully adjustable features to suit any operator
- Adjustable in length from 1,248mm to 1,436mm

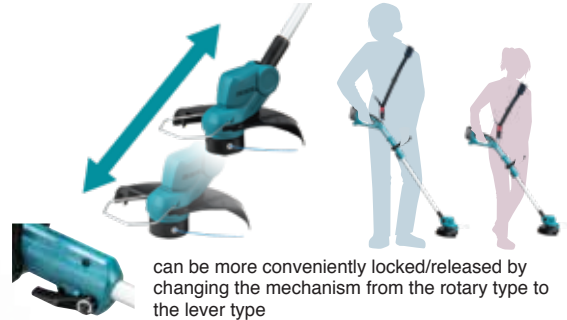

can be more conveniently locked/released by changing the mechanism from the rotary type to the lever type

Easy-to-operate front grip

Adjustable to a desired height by changing the angle and position



Angle adjustment of motor head

The cutting angle can be adjusted in 5 steps



Edger function

Using the grass trimmer as an edger is suitable for cutting the grass growing along the bricks or blocks



The nylon cutting head has a bump and feed mechanism



DUR193RF | DUR193Z

Cordless Grass Trimmer
Pemotong Rumput Tanpa Kord
充电式割草机



- Makita-built motor delivers 7,800 RPM for faster cutting
- Compact size is ideal for trimming and precise edging

Standard Equipment: Safety Goggles (195246-2), Shoulder Harness with Single Shoulder Strap, Nylon Cord

- RF: 1x Rapid Charger, 1x 3.0Ah Battery
- Z: Without Charger & Battery



Max Output Keluaran Maksima 最大输出	280W
Cutting Width Lebar Keratan 切割宽度	Nylon Cutting Head: 260mm (10-1/4")
No Load Speed (RPM) Kelajuan Tanpa Beban 回转速数	7,800
Dimensions (L x W x H) Dimensi 体积	1,248 - 1,436x265x358mm (49-1/4 - 56-1/2x10-3/8x14-1/8")
Net Weight Berat Bersih 淨重	2.3 - 2.6kg (5.1 - 5.7lbs.)
Continuous Usage Time (approx.) Masa Penggunaan Berterusan 连续使用时间	25 min with BL1830B Nylon cutting head with load

* All list price shown are for reference only (exclude SST).

* Semua harga yang ditunjukkan adalah untuk rujukan sahaja (tidak termasuk SST). 所有显示的建议零售价仅供参考 (不包括SST)。

Cordless
Target Area 30x30x30

LED Flashlight
Lampu Suhu LED
LED 闪光灯

Vacuum Cleaner
Pembersih Vakuum
吸尘器

Drilling / Fastening
Gergaji / Pengikat
钻孔 / 紧固

Impact Drilling / Demolition
Gergaji / Pemusnah
冲击钻孔 / 摧毁施工

Cutting
Pemotong
切割

Grinding / Sanding
Pengkilan / Poles
研磨 / 打磨

Sawing
Gergaji
锯切

Planing / Routing
Pengkilan / Tanggapan
刨削 / 雕刻

Others
Lain-lain
其他

Outdoor Power Equipment
Alatan Kuat Luar
园具 / 户外

Makita
1911



Li-ion Ah 6.0 | 5.0 | 4.0 | 3.0 | 2.0 | 1.5

DUR192LST | DUR192LZ

Cordless Grass Trimmer
Pemotong Rumput Tanpa Kord
充电式割草机



- Cost competitive model with increased output power

Standard Equipment: Nylon Cutting Head, Safety Goggles (195246-2), Band Assembly, Hex Wrench

- LST: 1x Standard Charger, 1x 5.0Ah Battery
- LZ: Without Charger & Battery



Max Output Keluaran Maksima 最大输出	460W
Cutting Width Lebar Keratan 切割宽度	Nylon Cutting Head: 300mm (11-3/4")
No Load Speed (RPM) Kelajuan Tanpa Beban 回转数	High: 0 - 4,500 Low: 0 - 6,000
Spindle Size Saiz Spinde 主轴尺寸	M10 x 1.25LH
Dimensions (L x W x H) Dimensi 体积	1,836x345x236mm (72-1/4x13-5/8x9-1/4")
Net Weight Berat Bersih 淨重	3.2 - 3.5kg (7.1 - 7.7lbs.)
Continuous Usage Time (approx.) Masa Penggunaan Berterusan 连续使用时间	High: 18 min Low: 34 min with BL1850B 300mm (11-3/4") Nylon Cutting Head

DUR191LRT2 | DUR191LZX2

Cordless Grass Trimmer
Pemotong Rumput Tanpa Kord
充电式割草机



- Lightweight and powerful cutting performance

Standard Equipment: Plastic Blade Set (198384-9), Safety Goggles (195246-2), Band Assembly, Accessory Bag, Hex Wrench

- LRT2: 1x Rapid Charger, 2x 5.0Ah Battery
- LZ2: Without Charger & Battery



Split shaft
for easily carried & store in car boot
Batang berasingan mudah dimasukkan dalam kereta
可拆分的把手 方便放入车箱

Max Output Keluaran Maksima 最大输出	240W
Cutting Width Lebar Keratan 切割宽度	Nylon Cutting Head: 300mm (11-3/4") Metal Blade: 230mm (9") Plastic Blade: 255mm (10")
No Load Speed (RPM) Kelajuan Tanpa Beban 回转数	3,500 - 6,000
Spindle Size Saiz Spinde 主轴尺寸	M10 x 1.25LH
Dimensions (L x W x H) Dimensi 体积	1,836x345x236mm (72-1/4x13-5/8x9-1/4")
Net Weight Berat Bersih 淨重	3.2 - 3.5kg (7.1 - 7.7lbs.)
Continuous Usage Time (approx.) Masa Penggunaan Berterusan 连续使用时间	Low: 74 min with BL1860B Plastic blade with load

DUR190LRT2 | DUR190LZX2

Cordless Grass Trimmer
Pemotong Rumput Tanpa Kord
充电式割草机



- Lightweight and powerful cutting performance

Standard Equipment: Plastic Blade Set (198384-9), Safety Goggles (195246-2), Band Assembly (125516-5), Accessory Bag, Hex Wrench

- LRT2: 1x Rapid Charger, 2x 5.0Ah Battery
- LZ2: Without Charger & Battery



Max Output Keluaran Maksima 最大输出	240W
Cutting Width Lebar Keratan 切割宽度	Nylon Cutting Head: 300mm (11-3/4") Metal Blade: 230mm (9") Plastic Blade: 255mm (10")
No Load Speed (RPM) Kelajuan Tanpa Beban 回转数	3,500 - 6,000
Spindle Size Saiz Spinde 主轴尺寸	M10 x 1.25LH
Dimensions (L x W x H) Dimensi 体积	1,836x348x236mm (72-1/4"x13-3/4"x9-1/4")
Net Weight Berat Bersih 淨重	2.9 - 3.2kg (6.4 - 7.1lbs.)
Continuous Usage Time (approx.) Masa Penggunaan Berterusan 连续使用时间	Low: 74 min with BL1860B Plastic blade with load *Depends on the density of weeds

DUR189Z

Cordless Grass Trimmer
Pemotong Rumput Tanpa Kord
充电式割草机



- Comfortable short telescopic pipe provides easy handling in tight spaces

Standard Equipment: Band Assembly, Accessory Bag, Nylon Cutting Head (198972-2), Hex Wrench

- Z: Without Charger & Battery

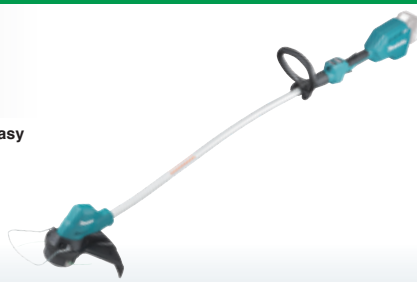

Max Output Keluaran Maksima 最大输出	240W
Cutting Width Lebar Keratan 切割宽度	Trimmer Head: 300mm (11-3/4") Plastic Blade: 255mm (10")
No Load Speed (RPM) Kelajuan Tanpa Beban 回转数	High: 6,000 Med: 5,000 Low: 4,000 ADT: 4,000 - 6,000
Spindle Size Saiz Spinde 主轴尺寸	M8 x 1.25RH
Dimensions (L x W x H) Dimensi 体积	1,518-1,618x258x369mm (59-3/4" - 63-3/4"x10-1/8"x14-1/2")
Net Weight Berat Bersih 淨重	3.1 - 3.4kg (6.8 - 7.5lbs.)
Continuous Usage Time (approx.) Masa Penggunaan Berterusan 连续使用时间	Low: 124 min Med: 54 min High: 46 min with BL1860B Nylon cutting head with load *Depends on the density of weeds

DUR188LRF | DUR188LZ

Cordless Grass Trimmer
Pemotong Rumput Tanpa Kord
充电式割草机



- Plastic triple blade for heavy duty operation

Standard Equipment: Band Assembly, Nylon Cutting Head, Accessory Bag, Hex Wrench

- LRF: 1x Rapid Charger, 2x 3.0Ah Battery
- LZ: Without Charger & Battery



Split shaft
for easily carried & store in car boot
Batang berasingan mudah dimasukkan dalam kereta
可拆分的把手 方便放入车箱



DUR187/188 VIDEO CLIP Models and specs may vary by country

Max Output Keluaran Maksima 最大输出	240W
Cutting Width Lebar Keratan 切割宽度	Nylon Cutting Head: 300mm (11-3/4") Plastic Blade: 255mm (10")
No Load Speed (RPM) Kelajuan Tanpa Beban 回转数	High: 6,000 Med: 5,000 Low: 4,000 ADT: 4,000 - 6,000
Spindle Size Saiz Spindel 主轴尺寸	M8 x 1.25 LH
Dimensions (L x W x H) Dimensi 体积	1,791x258x232mm (70-1/2"x10-1/8"x9-1/8")
Net Weight Berat Bersih 淨重	3.7 - 4.0kg (8.1 - 8.8lbs)
Continuous Usage Time (approx.) Masa Penggunaan Berterusan 连续使用时间	Low: 124 min Med: 54 min High: 46 min with BL1860B Nylon cutting head with load

* All list price shown are for reference only (exclude SST).

* Semua harga yang ditunjukkan adalah untuk rujukan sahaja (tidak termasuk SST). 所有显示的建议零售价仅供参考 (不包括SST)。

Cordless Target Kord 无绳式
LED Flashlight Lampu Suluh LED LED 照明灯
Vacuum Cleaner Pembasmi Vakuim 吸尘器
Drilling / Fastening Dremel / Pengikat 钻 / 紧固
Impact Drilling / Demolition Dremel / Penembak 冲击钻 / 拆除加工
Cutting Pemotong 切割
Grinding / Sanding Pengisar / Piskin 磨 / 砂
Sawing Cergas 电切
Planing / Routing Pengisar / Tangkapan 刨 / 雕刻
Others Lain-lain 其他
Outdoor Power Equipment Alatan Korsa Luar 户外动力工具





Li-ion Ah 6.0 5.0 4.0 3.0 2.0 1.5

DUR188URFE

Cordless Grass Trimmer
Pemotong Rumput Tanpa Kord
充电式割草機

- Plastic triple blade for heavy duty operation

Standard Equipment: Band Assembly, Nylon Cutting Head, Accessory Bag, Hex Wrench

- URFE : 1 x Rapid Charger, 2 x 3.0Ah Battery



Split shaft
for easily carried & store in car boot
Batang berasingan mudah dimasukkan dalam kereta
可拆分的把手
方便放入车箱

Max Output Keluaran Maksima 最大输出	240W
Cutting Width Lebar Keratan 切割宽度	Nylon Cutting Head: 300mm (11-3/4") Plastic Blade: 255mm (10")
No Load Speed (RPM) Kelajuan Tanpa Beban 回转数	High: 6,000 Med: 5,000 Low: 4,000 ADT: 4,000 - 6,000
Spindle Size Saiz Spinde 主轴尺寸	M8 x 1.25LH
Dimensions (L x W x H) Dimensi 体积	1,791x600x472mm (70-1/2"x23-5/8"x18-5/8")
Net Weight Berat Bersih 淨重	3.5 - 3.8kg (7.7 - 8.3lbs)
Continuous Usage Time (approx.) Masa Penggunaan Berterusan 连续使用时间	Low: 124 min Med: 54 min High: 46 min with BL1860B Nylon cutting head with load

DUR187LRFE | DUR187LZ

Cordless Grass Trimmer
Pemotong Rumput Tanpa Kord
充电式割草機

- 4 Mode rotation selection: 3 stages + ADT mode

Standard Equipment: Band Assembly, Nylon Cutting Head, Accessory Bag, Hex Wrench

- LRFE: 1x Rapid Charger, 2x 3.0Ah Battery
- LZ: Without Charger & Battery

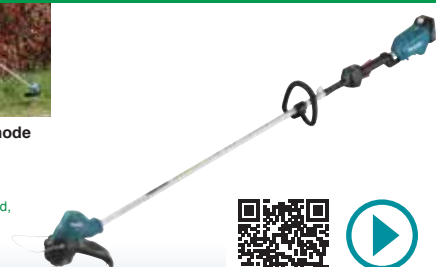

VIDEO CLIP
Models and specs may vary by country
DUR187/188

Max Output Keluaran Maksima 最大输出	240W
Cutting Width Lebar Keratan 切割宽度	Nylon Cutting Head: 300mm (11-3/4") Plastic Blade: 255mm (10")
No Load Speed (RPM) Kelajuan Tanpa Beban 回转数	High: 6,000 Med: 5,000 Low: 4,000 ADT: 4,000 - 6,000
Spindle Size Saiz Spinde 主轴尺寸	M8 x 1.25LH
Dimensions (L x W x H) Dimensi 体积	1,791x258x232mm (70-1/2"x10-1/8"x9-1/8")
Net Weight Berat Bersih 淨重	3.4 - 3.7kg (7.5 - 8.2lbs)
Continuous Usage Time (approx.) Masa Penggunaan Berterusan 连续使用时间	Low: 124 min Med: 54 min High: 46 min with BL1860B Nylon cutting head with load

DUR184LZ

Cordless Grass Trimmer
Pemotong Rumput Tanpa Kord
充电式割草機

- Low noise level for improved user comfort

Standard Equipment: Safety Goggles, Band Assembly, Nylon Cutting Head, Accessory Bag, Hex Wrench

- LZ : Without Charger & Battery



Max Output Keluaran Maksima 最大输出	250W
Cutting Width Lebar Keratan 切割宽度	Trimmer Head: 300mm (11-3/4")
Spindle Size Saiz Spinde 主轴尺寸	M8 x 1.25RH
Max Output Keluaran Maksima 最大输出	250W
No Load Speed (RPM) Kelajuan Tanpa Beban 回转数	High: 6,000 Low: 5,000
Dimensions (L x W x H) Dimensi 体积	1,534-1,634x258x417mm (60-1/2" - 64-1/2"x10-1/8"x16-3/8")
Net Weight Berat Bersih 淨重	3.1 - 3.4kg (6.8 - 7.5lbs)
Continuous Usage Time (approx.) Masa Penggunaan Berterusan 连续使用时间	80 min with BL1850B

DUR182LRF | DUR182LZ

Cordless Grass Trimmer
Pemotong Rumput Tanpa Kord
充电式割草機

- BL motor for faster cutting

Standard Equipment: Safety Goggles, Band Assembly, Nylon Cutting Head, Accessory Bag, Hex Wrench

- LRF : 1x Rapid Charger, 1x 3.0Ah Battery
- LZ : Without Charger & Battery



Max Output Keluaran Maksima 最大输出	250W
Cutting Width Lebar Keratan 切割宽度	Trimmer Head: 300mm (11-3/4") Metal Blade: 230mm (9")
No Load Speed (RPM) Kelajuan Tanpa Beban 回转数	3,500 - 6,000
Spindle Size Saiz Spinde 主轴尺寸	M8 x 1.25 LH
Dimensions (L x W x H) Dimensi 体积	1,843x287x253mm (72-1/2"x11-1/4"x10")
Net Weight Berat Bersih 淨重	3.6kg (8.0lbs)
Continuous Usage Time (approx.) Masa Penggunaan Berterusan 连续使用时间	61 min with BL1830B Nylon cutting head with load

DUR181Z

Cordless String Trimmer
Pemotong Rumput Tanpa Kord
充电式割草機

- Lightweight for reduced operator fatigue

Standard Equipment: Safety Goggles, Band Assembly, Nylon Cutting Head, Nylon Cord

- Z : Without Charger & Battery



Max Output Keluaran Maksima 最大输出	230W
Cutting Width Lebar Keratan 切割宽度	Trimmer Head: 260mm (10-1/4")
No Load Speed (RPM) Kelajuan Tanpa Beban 回转数	7,800
Dimensions (L x W x H) Dimensi 体积	1,229 - 1,433x267x186 - 257mm (48-1/2" - 56-1/2"x10-1/2"x7-3/8" - 10-1/8")
Net Weight Berat Bersih 淨重	2.8 - 3.1kg (6.2 - 6.9lbs.)
Continuous Usage Time (approx.) Masa Penggunaan Berterusan 连续使用时间	45 min with BL1830B Nylon cutting head with load

* All list price shown are for reference only (exclude SST).
* Semua harga yang ditunjukkan adalah untuk rujukan sahaja (tidak termasuk SST). 所有显示的建议零售价仅供参考 (不包括SST)。

Cordless
Target Area 3.0L x 3.0L

LED Flashlight
Lampu Suhu LED
LED照灯

Vacuum Cleaner
Pembersih Vakuum
吸尘器

Drilling / Fastening
Gantut / Pengikat
钻孔 / 紧固

Impact Drilling / Demolition
Gantut / Demolish
冲击钻孔 / 拆毁施工

Cutting
Pemotong
切割

Grinding / Sanding
Pengkilan / Pemoles
研磨 / 砂磨

Sawing
Gigitan
锯切

Planing / Routing
Pengkilan / Tumpang
刨削 / 压板

Others
Lain-lain
其他

Outdoor Power Equipment
Alatan Kuat Luar
园具/户外



18V

LXT

Li-ion Ah 6.0 5.0 4.0 3.0 2.0 1.5

DUX18RGX4 DUX18Z

Cordless Multi Function Power Head

Powerhead Pelbagai Fungsi
Tanpa Kord
充电式多功能动力机



*Not compatible with 2.0Ah, 1.5Ah batteries

- Split system of Power head and Attachment provides easier portability

Standard Equipment: Shoulder Harness, Hex Wrench, Safety Goggles (195246-2), Accessory Bag

- RGX4: 1x Rapid Charger, 1x 6.0Ah Battery, 1x Tool Bag, 1x Brushcutter Attachment EM408MP, 1x Nylon Cutting Head
- Z: Without Charger & Battery



Max Output Keluaran Maksima 最大输出	470W
No Load Speed (RPM) Kelajuan Tanpa Beban 回转数	High: 0 - 9,700 Low: 0 - 6,800
Dimensions (L x W x H) Dimensi 体积	983x318x175mm (38-3/4x12-1/2x6-7/8")
Net Weight Berat Bersih 淨重	2.8 - 3.1kg (6.2 - 6.8lbs.)

DLM330SM DLM330Z

Cordless Lawn Mower

Mesin Pemotong Rumput
Tanpa Kord
充电式手推割草机



- 3 in 1 (Cutting / Collecting / Mulching)
- Optimal for use in home garden where the ability to turn in a small radius is required

Standard Equipment: Blade, Mulching Plug, Wrench

- SM: 1x Standard Charger, 1x 4.0Ah Battery
- Z: Without Charger & Battery



Max Output Keluaran Maksima 最大输出	450W
Cutting Width Lebar Keratan 切割宽度	330mm (13")
Cutting Height Ketinggian Pemotongan 切割高度	20 - 75mm (13/16 - 2-15/16")
Grass Box Capacity Kapasiti Kotak Rumput 草箱容量	30L
No Load Speed (RPM) Kelajuan Tanpa Beban 回转数	4,300
Dimensions (L x W x H) Dimensi 体积	1,285-1,350x375x935-975mm (50-1/2-53x14-3/4x36-3/4-38-3/8")
Net Weight Berat Bersih 淨重	11.6 - 12.5kg (25.6 - 27.6lbs.)
Continuous Usage Time (approx.) Masa Penggunaan Berterusan 连续使用时间	Mowing Area 270m ² or 14 min with BL1840B

DLM230SF DLM230Z 230mm (9")

Cordless Lawn Mower

Mesin Pemotong Rumput
Tanpa Kord
充电式手推割草机



- 2 in 1 (Lawnmowing / Grass collecting)
- Newly designed Handle folding structure and compact storage

Standard Equipment: Blade, Hex wrench, Rod

- SF: 1x Standard Charger, 1x 3.0Ah Battery
- Z: Without Charger & Battery



Max Output Keluaran Maksima 最大输出	560W
Cutting Width Lebar Keratan 切割宽度	230mm
Cutting Height Ketinggian Pemotongan 切割高度	10 - 55mm
Grass Box Capacity Kapasiti Kotak Rumput 草箱容量	20L
No Load Speed (RPM) Kelajuan Tanpa Beban 回转数	7,000
Dimensions (L x W x H) Dimensi 体积	860 - 1,105x256x680 - 920mm
Net Weight Berat Bersih 淨重	8.6 - 8.9kg
Continuous Usage Time (approx.) Masa Penggunaan Berterusan 连续使用时间	Mowing Area 90m ² or 6 min with BL1830B

DLM160Z

Cordless Hand Push Lawn Trimmer

Mesin Pemotong Rumput
Tanpa Kord
充电式手推草坪修剪机

- World's First Cordless Hand Push Lawn Trimmer

Standard Equipment: Rotary Blade, Fixed Blade, Lock Nut Wrench

- Z: Without Charger & Battery



Cutting Width Lebar Keratan 切割宽度	160mm (6-5/16")
Cutting Height Ketinggian Pemotongan 切割高度	10 / 15 / 20 / 25 / 30 / 35 / 40mm
Grass box capacity Kapasiti Kotak Rumput 草箱容量	8.4L
No Load Speed (RPM) Kelajuan Tanpa Beban 回转数	1,600
Wheel Size Saiz Roda 轮片尺寸	Front / Rear: 230mm (9")
Dimensions (L x W x H) Dimensi 体积	346x178x751-1,046mm
Net Weight Berat Bersih 淨重	5.8kg
Continuous Usage Time (approx.) Masa Penggunaan Berterusan 连续使用时间	Mowing Area 190m ² or 39 min with BL1860B

DUH754SRT DUH754SZ 750mm (29-1/2")

Cordless Hedge Trimmer

Pemangkas Tanaman Pagar
Tanpa Kord
充电式篱笆修剪机



- Excellent balance of high power and lightweight

Standard Equipment: Blade Cover, Chip Receiver, Safety Goggles (195246-2)

- SRT: 1x Rapid Charger, 1x 5.0Ah Battery
- SZ: Without Charger & Battery



Blade Length Panjang bilah 刀片长度	750mm (29-1/2")
Strokes Per Minute (SPM) Kelajuan Strok 冲程速度	High: 4,400 Med: 3,600 Low: 2,000
Tooth Spacing Selang Gigi 牙齿间隔	35mm (1-3/8")
Max Cutting Capacity Kapasiti Pemotongan Maksimum 最大切割能力	23.5mm (15/16")
Dimensions (L x W x H) Dimensi 体积	1,200x282x143mm (47-1/4"x11-1/8"x5-5/8")
Net Weight Berat Bersih 淨重	3.4 - 3.9kg (7.5 - 8.6lbs.)
Continuous Usage Time (approx.) Masa Penggunaan Berterusan 连续使用时间	Low: 190 min Med: 80 min High: 65 min with BL1860B

* All list price shown are for reference only (exclude SST).

* Semua harga yang ditunjukkan adalah untuk rujukan sahaja (tidak termasuk SST). 所有显示的建议零售价仅供参考 (不包括SST)。

Cordless Target Kord 无绳式

LED Flashlight Lampu Suluh LED LED 手电筒

Vacuum Cleaner Pembersih Vakuum 吸尘器

Drilling / Fastening Dremel / Pengikat 钻头 / 紧固件

Impact Drilling / Demolition Dremel / Pemusnah 冲击钻头 / 拆除加工

Cutting Pemotong 切割

Grinding / Sanding Pengisar / Poles 研磨 / 打磨

Sawing Mengkilat 锯切

Planing / Routing Pengisar / Tangkap 刨削 / 雕刻

Others Lain-lain 其他

Outdoor Power Equipment Alatan Kerja Luar 户外动力工具

Makita



Li-ion Ah 6.0 5.0 4.0 3.0 2.0 1.5

DUH601Z 600mm (23-5/8")

Cordless Hedge Trimmer
Pemangkas Tanaman Pagar Tanpa Kord
充电式篱笆树剪



- 5-Position rotating rear handle for increased comfort during vertical and angle trimming

Standard Equipment: Shear Blade Assembly Set (199099-1), Blade Cover (412911-1), Safety Goggles (195246-2)

• Z: Without Charger & Battery



DUH601



VIDEO CLIP
Models and specs may vary by country

Blade Length Panjang bilah 刀片长度	600mm (23-5/8")
Strokes Per Minute (SPM) Kelajuan Strok 冲程速度	High: 0 - 4,400 Med: 0 - 3,600 Low: 0 - 2,000
Max Cutting Capacity Kapasiti Pemotongan Maksimum 最大切割能力	23.5mm (15/16")
Tooth Spacing Selang Gigi 牙齿间隔	35mm (1 - 3/8")
Dimensions (L x W x H) Dimensi 体积	1,121x192x225mm (44-1/8"x7-1/2"x8-7/8")
Net Weight Berat Bersih 净重	3.8 - 4.5kg (8.4 - 9.8lbs.)
Continuous Usage Time (approx.) Masa Penggunaan Berterusan 连续使用时间	Low: 200 min High: 55 min with BL1860B

DUH523RME | DUH523RFE | DUH523Z 520mm (20-1/2")

Cordless Hedge Trimmer
Pemangkas Tanaman Pagar Tanpa Kord
充电式篱笆树剪



- Delivers 2,700 SPM for increased cutting speed

Standard Equipment: Blade Cover (452685-2)

- RME: 1x Rapid Charger, 2x 4.0Ah Battery
- RFE: 1x Rapid Charger, 2x 3.0Ah Battery
- Z: Without Charger & Battery



Blade Length Panjang bilah 刀片长度	520mm (20-1/2")
Strokes Per Minute (SPM) Kelajuan Strok 冲程速度	2,700
Tooth Spacing Selang Gigi 牙齿间隔	15mm (9/16")
Dimensions (L x W x H) Dimensi 体积	938x195x193mm (37"x7-5/8"x7-5/8")
Max Output Keluasan Maksima 最大输出	210W
Net Weight Berat Bersih 净重	3.0 - 3.4kg (6.7 - 7.5lbs)
Continuous Usage Time (approx.) Masa Penggunaan Berterusan 连续使用时间	130 min with BL1850B

DUN600LZ 600mm (23-5/8")

Cordless Hedge Trimmer
Pemangkas Tanaman Pagar Tanpa Kord
充电式篱笆树剪



- Lightweight for reduced operator fatigue

Standard Equipment: Blade Cover, Hex Wrench

• LZ: Without Charger & Battery



DUN600L



VIDEO CLIP
Models and specs may vary by country

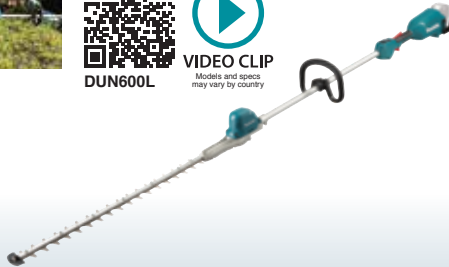

Blade Length Panjang Bilah 刀片长度	600mm (23-5/8")
Strokes Per Minute (SPM) Kelajuan Strok 冲程速度	High: 4,400 Med: 3,600 Low: 2,000
Tooth Spacing Selang Gigi 牙齿间隔	35mm (1-3/8")
Max Cutting Capacity Kapasiti Pemotongan Maksimum 最大切割能力	23.5mm (15/16")
Dimensions (L x W x H) Dimensi 体积	2,050x230x178mm (80-1/2"x9"x7")
Net Weight Berat Bersih 净重	3.7 - 4.1kg (8.2 - 9.0lbs.)
Continuous Usage Time (approx.) Masa Penggunaan Berterusan 连续使用时间	Low: 180 min Med: 80 min High: 55 min with BL1860B

DUN500WZ 500mm (19-3/4")

Cordless Hedge Trimmer
Pemangkas Tanaman Pagar Tanpa Kord
充电式篱笆树剪



- Lightweight for reduced operator fatigue

Standard Equipment: Blade Cover, Band Assembly

• WZ: Without Charger & Battery



DUN500W



VIDEO CLIP
Models and specs may vary by country

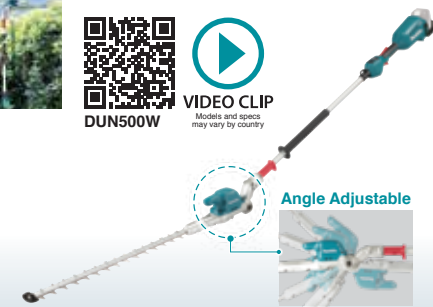

Angle Adjustable

Blade Length Panjang Bilah 刀片长度	500mm (19-3/4")
Strokes Per Minute (SPM) Kelajuan Strok 冲程速度	High: 4,400 Med: 3,600 Low: 2,000
Tooth Spacing Selang Gigi 牙齿间隔	35mm (1-3/8")
Max Cutting Capacity Kapasiti Pemotongan Maksimum 最大切割能力	23.5mm (15/16")
Dimensions (L x W x H) Dimensi 体积	2,115x97x137mm (83-1/4"x3-13/16"x5-3/8")
Net Weight Berat Bersih 净重	3.9 - 4.3kg (8.6 - 9.5lbs.)
Continuous Usage Time (approx.) Masa Penggunaan Berterusan 连续使用时间	Low: 190 min Med: 90 min High: 60 min with BL1860B

DUN461WZ 460mm (18-1/8")

Cordless Pole Hedge Trimmer
Pemangkas Tanaman Pagar Tinggi Tanpa Kord
充电式高枝篱笆树剪



- Trim tall hedges or prune the twigs or thin branches of tall trees without using stepladder

Standard Equipment: Blade Cover

• WZ: Without Charger & Battery



Blade Length Panjang Bilah 刀片长度	460mm (18-1/8")
Strokes Per Minute (SPM) Kelajuan Strok 冲程速度	3,600
Tooth Spacing Selang Gigi 牙齿间隔	28mm (1-1/8")
Max Cutting Capacity Kapasiti Pemotongan Maksimum 最大切割能力	18mm (11/16")
Dimensions (L x W x H) Dimensi 体积	1,889-2,511x87x134mm (74-1/2"-99x3-7/16x5-1/4")
Net Weight Berat Bersih 净重	3.0 - 3.3kg (6.6 - 7.3lbs.)
Continuous Usage Time (approx.) Masa Penggunaan Berterusan 连续使用时间	122 min with BL1850B

* All list price shown are for reference only (exclude SST).

* Semua harga yang ditunjukkan adalah untuk rujukan sahaja (tidak termasuk SST). 所有显示的建议零售价仅供参考 (不包括SST)。

Cordless
Targeted Jobs

LED Flashlight
Lampu Suhu LED
LED明亮

Vacuum Cleaner
Pembersih Vakuum
吸尘器

Drilling / Fastening
Gergaji / Pengikat
钻孔 / 紧固

Impact Drilling / Demolition
Gergaji / Pemusnah
冲击钻孔 / 拆除施工

Cutting
Pemotong
切割

Grinding / Sanding
Pengkilan / Pemoles
研磨 / 砂磨

Sawing
Gergaji
锯切

Planing / Routing
Pengkilan / Tergamit
刨削 / 雕刻

Others
Lain-lain
其他

Outdoor Power Equipment
Alatan Kuasa Luar
园具/户外





Li-ion Ah 6.0 | 5.0 | 4.0 | 3.0 | 2.0 | 1.5

Cordless
Target Kord 无绳式

LED Flashlight
Lampu Sulu LED
LED 照明灯

Vacuum Cleaner
Pembersih Vakuum
吸尘器

Drilling / Fastening
Drobul / Pengikat
钻孔 / 紧固

Impact Drilling / Demolition
Gardu / Perseksi
冲击钻孔 / 拆除加工

Cutting
Pemotong
切割机

Grinding / Sanding
Pengisar / Poles
打磨 / 研磨

Sawing
Gergaji
电锯

Planing / Routing
Pengaram / Tampam
刨削 / 雕刻

Others
Lain-lain
其他

Outdoor Power Equipment
Alatan Kerja Luar
园林-户外

Makita
1915

DUM604Z 160mm (6-5/16")

Cordless Grass Shear
Pemotong Rumput Tanpa Kord
充电式割草机



- 2 in 1: trimmer and shear blade can be attached



Standard Equipment: Grass Receiver, Blade Cover

- Z: Without Charger & Battery

Cutting Width Lebar Keratan 切割宽度	160mm (6-5/16")
Depth Adjustment Pelarasan Kedalaman 深度调整	15mm (9/16") 20mm (13/16") 25mm (1")
Strokes Per Minute (SPM) Kelajuan Strok 冲程速度	2,500
Dimensions (L x W x H) Dimensi 体积	337x177x131mm (13-1/4"x7"x5-1/8")
Net Weight Berat Bersih 净重	1.4 - 1.8kg (3.2 - 4.0 lbs)
Continuous Usage Time (approx.) Masa Penggunaan Berterusan 连续使用时间	200 min with BL1850B 250 min with BL1860B

DUM111SYX 110mm (4-5/16")

Cordless Grass Shear
Pemotong Rumput Tanpa Kord
充电式割草机



- 2 in 1: Both trimmer blade and shear blade can be attached



Standard Equipment:
Grass Shear Blade 110mm (191N23-4),
Grass Shear Blade 110mm Cover (413885-9),
Hedge Trimmer Blade 200mm (198408-1),
Blade Cover Set (195274-7), Oil Vessel
(to include hedge trimmer part)



- SYX: 1x Standard Charger, 1x 1.5Ah Battery

Cutting Width Lebar Keratan 切割宽度	Grass Shear Blade: 110mm (4-5/16") Hedge Trimmer Blade: 200mm (7-7/8")
Depth Adjustment Pelarasan Kedalaman 深度调整	15mm (9/16") 20mm (13/16") 25mm (1")
Strokes Per Minute (SPM) Kelajuan Strok 冲程速度	2,500
Dimensions (L x W x H) Dimensi 体积	330x120x130mm (13x4-3/4x5-1/8")
Net Weight Berat Bersih 净重	1.4 - 1.8kg (3.1 - 4.0 lbs.)
Continuous Usage Time (approx.) Masa Penggunaan Berterusan 连续使用时间	220 min with BL1850B

DUC254Z 250mm (10")

Cordless Chain Saw
Gergaji Rantai Tanpa Kord
充电式链锯



- High Cutting Performance, Ultra Lightweight Top Handle Chain Saw



Standard Equipment: Saw Chain (199075-5),
Guide Bar (161846-0), Guide Bar Cover (458501-6/ 452093-7)

- Z: Without Charger & Battery



Guide Bar Length Panjang Bar Panduan 导板长度	250mm (10")
Chain Pitch Kerapatan Rantai 链条齿距	9.5mm (3/8")
Chain Gauge Ketebalan Rantai 链条厚度	1.1 (0.043") or 1.3mm (0.050")
Chain Speed Kelajuan Rantai 链条速度	0 - 24m/s (0 - 1,440m/min) (0 - 4,720FPM)
Chain Oil Tank Volume Tangki Minyak Pelincir 链油箱	140mL (4.8US oz)
Dimensions (L x W x H) Dimensi 体积	256x185x190mm (10-1/8"x7-1/2"x7-1/4")
Net Weight Keberatan 净重	2.8 - 3.3kg (6.3 - 7.3lbs)
Work Amount (approx.) Jumlah Kerja 工作量	160 cuts with BL1850B 50 mm Cedar timber

DUB184RT | DUB184Z

Cordless Blower
Mesin Penghembus Angin
Tanpa Kord
充电式吹风机



- Compact and lightweight for single handed operation



Standard Equipment: Nozzle, Hex Wrench

- RT: 1x Rapid Charger, 1x 5.0Ah Battery
- Z: Without Charger & Battery



Max Air Volume Isipadu Angin Maksimum 最大风量	13.0m³/min (459CFM)
Max Air Velocity Velositi Angin Maksimum 最大风速	52.1m/s (116MPH)
No Load Speed (RPM) Kelajuan Tanpa Beban 回转数	0 - 18,000
Dimensions (L x W x H) Dimensi 体积	825x160x285mm (32-1/2"x6-5/16"x11-1/4")
Net Weight Berat Bersih 净重	2.5 - 3.0kg (5.4 - 6.7lbs.)
Continuous Usage Time (approx.) Masa Penggunaan Berterusan 连续使用时间	12 min with BL1860B



DUB186Z

Cordless Blower
Mesin Penghembus Angin
Tanpa Kord
充电式吹风机

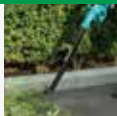

- Compact and lightweight for single handed operation



Standard Equipment: Garden Nozzle (191G09-6)

- Z: Without Charger & Battery



Max Air Volume Isipadu Angin Maksimum 最大风量	3.2m³/min
Max Air Velocity Velositi Angin Maksimum 最大风速	68m/s
Avg. Air Velocity Kelajuan Angin Purata 平均风速	56m/s
No Load Speed (RPM) Kelajuan Tanpa Beban 回转数	0 - 18,000
Dimensions (L x W x H) Dimensi 体积	861x156x210mm (34x6-1/8x8-1/4")
Net Weight Berat Bersih 净重	1.6 - 2.1kg (3.5 - 4.6lbs.)
Continuous Usage Time (approx.) Masa Penggunaan Berterusan 连续使用时间	Low: 130 min Med: 50 min High: 20 min with BL1850B

* All list price shown are for reference only (exclude SST).

* Semua harga yang ditunjukkan adalah untuk rujukan sahaja (tidak termasuk SST). 所有显示的建议零售价仅供参考 (不包括SST)。



Li-ion Ah 6.0 5.0 4.0 3.0 2.0 1.5

DUB185Z

Cordless Blower
Mesin Penghembus Angin Tanpa Kord
充电式吹风机



- Larger air volume has been obtained by increasing the air outlet diameter

Standard Equipment: Nozzle

• Z: Without Charger & Battery



Max Air Volume Isipadu Angin Maksimum 最大风量	3.2m ³ /min
Max Air Velocity Velositi Angin Maksimum 最大风速	98m/s
Avg. Air Velocity Kelajuan Angin Purata 平均风速	81m/s
Max Sealed Suction Sedutan Terkedap 最大密封吸力	5.8kPa
No Load Speed (RPM) Kelajuan Tanpa Beban 回转数	0 - 18,000
Dimensions (L x W x H) Dimensi 体积	517x156x210mm (20-3/8x6-1/8x8-1/4")
Net Weight Berat Bersih 净重	1.6 - 2.1kg (3.5 - 4.6lbs.)
Continuous Usage Time (approx.) Masa Penggunaan Berterusan 连续使用时间	Low: 130 min Med: 50 min High: 21 min with BL1850B

DVF154Z 15L

Cordless Garden Sprayer
Penyembur Tanaman Tanpa Kord
充电式花园喷雾器



- Reduced running cost with Li-ion battery

Standard Equipment: Upright Double-Headed Nozzle, Wide-Angle Herbicide Nozzle, Spray Pipe Holder, Shoulder Harness

• Z: Without Charger & Battery



Max Pressure Tekanan Maksimum 最大水压	0.3MPa (3 kgf/cm ²)
Chemical Tank Tangki Kimia 化学箱容量	15L
Dimensions (L x W x H) Dimensi 体积	345x235x525mm (13-5/8"x9-1/4"x20-3/4")
Net Weight Berat Bersih 净重	4.1 - 4.4kg (9.1 - 9.7lbs)
Continuous Usage Time (approx.) Masa Penggunaan Berterusan 连续使用时间	Wide Angle Nozzle 344 min Double Nozzle 215 min with BL1850B

DUS054Z 5L

Cordless Garden Sprayer
Penyembur Tanaman Tanpa Kord
充电式花园喷雾器



- 2-mode selectable (Mist and Stream modes)

Standard Equipment: H-Shaped Double Head Nozzle, Spray Wand, Spray Wand Holder, Shoulder Belt

• Z: Without Charger & Battery



Max Pressure Tekanan Maksimum 最大水压	0.3Mpa (3 kgf/cm ²)
Chemical Tank Tangki Kimia 化学箱容量	5L
Hose Length Panjang Hos 软管长度	1.7m
Spray Wand Length Panjang Batang Semburan 喷雾棒长度	0.5 - 0.7m
Nozzle Mounting Thread Benang Pemasangan Muncung 喷嘴安装螺纹	G 1/4
Dimensions (L x W x H) Dimensi 体积	343x182x368mm (13-1/2x7-1/8x14-1/2")
Net Weight Berat Bersih 净重	3.2 - 3.5kg (7.1 - 7.7lbs.)
Work Amount (approx.) Jumlah Kerja 工作量	170L (double outlet mist) 110L (single outlet mist) 205L (double outlet stream) 140L (single outlet stream) with BL1830B

DCU180Z Bucket Set / Carier Set

Battery Powered Wheelbarrow
Kereta Sorong Berkuasa Bateri
充电式搬运车



- Ideal for use at urban construction sites and on farms

Standard Equipment: Lock Key, Support Legs, Wrenches

• Z: Without Charger & Battery



Max Load Capacity Kapasiti Berat Maksimum 最重载量	130kg (290lbs.)
Traveling Speed Kelajuan Perjalanan 行驶速度	Forward High: 0 - 3.5km/h Forward Low: 0 - 1.5km/h Reverse: 0 - 1 km/h
Max Climbing Capacity Pergerakan atas Kecerunan Maksimum 最大爬坡能力	12°
Dimensions (L x W x H) Dimensi 体积	When carrier is installed/ During operation: 1,315x1,060x900mm (51-3/4"x41-3/4"x35-1/2") When carrier is installed/ When stored: 1,110x820x820mm (43-3/4"x32-1/4"x32-1/4") When bucket is installed/ During operation: 1,310x820x900 mm (51-1/2"x32-1/4"x35-1/2") When bucket is installed/ When stored: 1,110x820x820mm (43-3/4"x32-1/4"x32-1/4")
Net Weight Keberatan 净重	39.3 - 44.8kg (86.5 - 98.7lbs)
Continuous Usage Time (approx.) Masa Penggunaan Berterusan 连续使用时间	120 min with BL1860B x2



* All list price shown are for reference only (exclude SST).

* Semua harga yang ditunjukkan adalah untuk rujukan sahaja (tidak termasuk SST). 所有显示的建议零售价仅供参考 (不包括SST)。

Cordless Targeted Blower
LED Flashlight Lampu Suli LED LED手电筒
Vacuum Cleaner Pembasmi Vakum 吸尘器
Drilling / Fastening Gergaji / Pengikat 钻孔 / 紧固
Impact Drilling / Demolition Gergaji / Pembasmi 冲击钻孔 / 拆除
Cutting Pemotong 切割
Grinding / Sanding Pengkilan / Poles 研磨 / 砂磨
Sawing Gergaji 锯切
Planing / Routing Pengkilan / Tanggung 刨削 / 雕刻
Others Lain-lain 其他
Outdoor Power Equipment Alatan Kuat Luar 户外动力设备





Cordless
Target Kord 无绳
LED Flashlight
Lampu Suluhi LED
LED 手电筒
Vacuum Cleaner
Pembersih Vakuum
Blower
Drilling / Fastening
Gardu / Pengikat
Impact Drilling / Demolition
Gardu / Persekolah
Gardu / Pengikat
Cutting
Pemotong
Grinding / Sanding
Pengisar / Pasir
Sawing
Gergaji
Planing / Routing
Pengisar / Tangkai
Others
Lain-lain
Outdoor Power Equipment
Alatan Kerja Luar
Makita
1921

DF332DSME | DF332DSAE | DF332DZ 10mm (3/8")

Cordless Driver Drill
Gerudi Pemutar Skru Tanpa Kord
充电式螺丝起子电钻

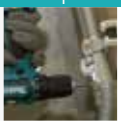

- BL motor with high power

Standard Equipment: Phillips Bit, Belt Clip

- DSME: 1x Speed Charger, 2x 4.0Ah Battery
- DSAE: 1x Speed Charger, 2x 2.0Ah Battery
- DZ: Without Charger, Battery & Carrying Case



Capacity Kapasiti 能力	Steel: 10 (3/8") Wood: 28mm (1-1/8")
Chuck Capacity Kapasiti Chuck 夹头能力	0.8 - 10mm (1/32 - 3/8")
No Load Speed (RPM) Kelajuan Tanpa Beban 回转速数	High: 0 - 1,500 Low: 0 - 450
Max Fastening Torque Maksimum Tenaga Pemutaran Pengancing 最大紧固扭力	Hard: 35N-m (310in.lbs.) Soft: 21N-m (190in.lbs.)
Max Lock Torque Pemutaran Tenaga Maksimum 最大锁紧扭力	32N-m (280in.lbs.)
Dimensions (L x W x H) Dimensi 体积	154x66x217mm (6-1/16"x2-5/8"x8-1/2")
Net Weight Berat Bersih 净重	1.0 - 1.2kg (2.3 - 2.6lbs)
Work Amount (approx.) Jumlah Kerja 工作量	460 holes with BL1021B Drilling ø9mm Auger Bit, Melapi 30mm Thickness

DF333DSME | DF333DWAE | DF333DWYE | DF333DZ 10mm (3/8")

Cordless Driver Drill
Gerudi Pemutar Skru Tanpa Kord
充电式螺丝起子电钻



- Increased motor power for higher speed and max tightening torque

Standard Equipment: Phillips Bit, Belt Clip

- DSME: 1x Speed Charger, 2x 4.0Ah Battery
- DWAE: 1x Standard Charger, 2x 2.0Ah Battery
- DWYE: 1x Standard Charger, 2x 1.5Ah Battery
- DZ: Without Charger, Battery & Carrying Case



Capacity Kapasiti 能力	Steel: 10mm (3/8") Wood: 21mm (13/16")
Chuck Capacity Kapasiti Chuck 夹头能力	0.8 - 10mm (1/32 - 3/8")
No Load Speed (RPM) Kelajuan Tanpa Beban 回转速数	High: 0 - 1,700 Low: 0 - 450
Max Fastening Torque Maksimum Tenaga Pemutaran Pengancing 最大紧固扭力	Hard: 30N-m (270in.lbs.) Soft: 14N-m (130in.lbs.)
Max Lock Torque Pemutaran Tenaga Maksimum 最大锁紧扭力	28N-m (250in.lbs.)
Dimensions (L x W x H) Dimensi 体积	179x66x212mm (7"x2-5/8"x8-3/8")
Net Weight Berat Bersih 净重	1.1 - 1.2kg (2.4 - 2.7lbs.)
Work Amount (approx.) Jumlah Kerja 工作量	350 holes with BL1021B Drilling ø9mm Auger Bit, Melapi 30mm Thickness

DF331DSME | DF331DZ 10mm (3/8")

Cordless Driver Drill
Gerudi Pemutar Skru Tanpa Kord
充电式螺丝起子电钻



- Increased motor power for higher speed

Standard Equipment: Phillips Bit, Belt Clip

- DSME: 1x Speed Charger, 2x 4.0Ah Battery
- DZ: Without Charger, Battery & Carrying Case



Capacity Kapasiti 能力	Steel: 10mm (3/8") Wood: 21mm (13/16")
Chuck Capacity Kapasiti Chuck 夹头能力	0.8 - 10mm (1/32 - 3/8")
No Load Speed (RPM) Kelajuan Tanpa Beban 回转速数	High: 0 - 1,700 Low: 0 - 450
Max Fastening Torque Maksimum Tenaga Pemutaran Pengancing 最大紧固扭力	Hard: 30N-m (270in.lbs.) Soft: 14N-m (130in.lbs.)
Max Lock Torque Pemutaran Tenaga Maksimum 最大锁紧扭力	28N-m (250in.lbs.)
Dimensions (L x W x H) Dimensi 体积	189x66x209mm (7-7/16"x2-5/8"x8-1/4")
Net Weight Berat Bersih 净重	1.1 - 1.3kg (2.4 - 2.8lbs)
Work Amount (approx.) Jumlah Kerja 工作量	350 holes with BL1021B Drilling ø9mm Auger Bit, Melapi 30mm Thickness

DF032DSME | DF032DSAE | DF032DZ 10mm (3/8")

Cordless Driver Drill
Gerudi Pemutar Skru Tanpa Kord
充电式螺丝起子电钻



- BL motor with high power

Standard Equipment: Phillips Bit, Belt Clip

- DSME: 1x Speed Charger, 2x 4.0Ah Battery
- DSAE: 1x Speed Charger, 2x 2.0Ah Battery
- DZ: Without Charger, Battery & Carrying Case



Capacity Kapasiti 能力	Steel: 10mm (3/8") Wood: 28mm (1-1/8")
Chuck Capacity Kapasiti Chuck 夹头能力	6.35mm (1/4")
No Load Speed (RPM) Kelajuan Tanpa Beban 回转速数	High: 0 - 1,500 Low: 0 - 450
Max Fastening Torque Maksimum Tenaga Pemutaran Pengancing 最大紧固扭力	Hard: 35N-m (310in.lbs.) Soft: 21N-m (190in.lbs.)
Max Lock Torque Pemutaran Tenaga Maksimum 最大锁紧扭力	32N-m (280in.lbs.)
Dimensions (L x W x H) Dimensi 体积	124x66x217mm (4-7/8"x2-5/8"x8-1/2")
Net Weight Berat Bersih 净重	0.88 - 1kg (1.9 - 2.3lbs)
Work Amount (approx.) Jumlah Kerja 工作量	200 holes with BL1021B Wood Drilling ø3x1.6mm

DF033DSME | DF033DWAE | DF033DZ 10mm (3/8")

Cordless Driver Drill
Gerudi Pemutar Skru Tanpa Kord
充电式螺丝起子电钻



- Increased motor power for higher speed and max tightening torque

Standard Equipment: Phillips Bit, Belt Clip

- DSME: 1x Speed Charger, 2x 4.0Ah Battery
- DWAE: 1x Standard Charger, 2x 2.0Ah Battery
- DZ: Without Charger, Battery & Carrying Case



Capacity Kapasiti 能力	Steel: 10mm (3/8") Wood: 21mm (13/16")
Chuck Capacity Kapasiti Chuck 夹头能力	6.35mm (1/4")
No Load Speed (RPM) Kelajuan Tanpa Beban 回转速数	High: 0 - 1,700 Low: 0 - 450
Max Fastening Torque Maksimum Tenaga Pemutaran Pengancing 最大紧固扭力	Hard: 30N-m (270in.lbs.) Soft: 14N-m (130in.lbs.)
Max Lock Torque Pemutaran Tenaga Maksimum 最大锁紧扭力	28N-m (250in.lbs.)
Dimensions (L x W x H) Dimensi 体积	149x66x212mm (5-7/8"x2-5/8"x8-3/8")
Net Weight Berat Bersih 净重	0.9 - 1.1kg (2.1 - 2.4lbs.)
Work Amount (approx.) Jumlah Kerja 工作量	160 holes with BL1021B Wood Drilling ø3x1.6mm

* All list price shown are for reference only (exclude SST).

* Semua harga yang ditunjukkan adalah untuk rujukan sahaja (tidak termasuk SST). 所有显示的建议零售价仅供参考 (不包括SST)。



DF031DWAE | DF031DWYE | DF031DZ 10mm (3/8")

Cordless Driver Drill
Gerudi Pemutar Skru Tanpa Kord
充电式螺丝起子电钻



• Ideal for work in tight spaces

Standard Equipment: Phillips Bit, Belt Clip

- DWAE: 1x Standard Charger, 2x 2.0Ah Battery
- DWYE: 1x Standard Charger, 2x 1.5Ah Battery
- DZ: Without Charger, Battery & Carrying Case



Capacity Kapasiti 能力	Steel: 10mm (3/8") Wood: 21mm (13/16") 6.35mm (1/4")
Hex Shank Batang Heksagon 六角柄	
No Load Speed (RPM) Kelajuan Tanpa Beban 回转数	High: 0 - 1,700 Low: 0 - 450
Max Fastening Torque Maksimum Tenaga Pemutaran Pengancing 最大紧固扭力	Hard: 30N-m (270in.lbs.) Soft: 14N-m (130in.lbs.)
Max Lock Torque Pemutaran Tenaga Maksimum 最大锁紧扭力	28N-m (250in.lbs.)
Dimensions (L x W x H) Dimensi 体积	157x66x209mm (6-3/16"x2-5/8"x8-1/4")
Net Weight Berat Bersih 净重	0.94 - 1.1kg (2.1 - 2.5lbs)
Work Amount (approx.) Jumlah Kerja 工作量	160 holes with BL1021B Wood Drilling ø3x1.6mm

Model No. 型号	Capacity Kapasiti 能力		No Load Speed (rpm) Kelajuan Tanpa Beban 回转数	Mechanical Speed Mekanikal Kelajuan 机械速度	Torque Setting Tetapan Pemutaran 扭转设置	Max. Fastening Torque Maksimum Tenaga Pemutaran Pengancing 最大紧固扭力	Overall Length (mm) Panjang Keseluruhan 总长度	Net Weight Berat Bersih 净重	BL MOTOR	XPT
	Steel	Wood								
DF332D	10mm	28mm	0-1,500 / 0-450	2 Speed	20	Hard: 35 / Soft: 21	154	1.0kg (2.3lbs)	●	●
DF032D	10mm	28mm	0-1,500 / 0-450	2 Speed	20	Hard: 35 / Soft: 21	124	0.88kg (1.9lbs)	●	
DF333D	10mm	21mm	0-1,700 / 0-450	2 Speed	20	Hard: 30 / Soft: 14	179	1.1kg (2.4lbs)		
DF033D	10mm	21mm	0-1,700 / 0-450	2 Speed	20	Hard: 30 / Soft: 14	149	0.9kg (2.1lbs)		
DF331D	10mm	21mm	0-1,700 / 0-450	2 Speed	18	Hard: 30 / Soft: 14	189	1.1kg (2.4lbs)		
DF031D	10mm	21mm	0-1,700 / 0-450	2 Speed	18	Hard: 30 / Soft: 14	157	0.94kg (2.1lbs)		

HP332DSME | HP332DSAE | HP332DZ 10mm (3/8")

Cordless Hammer Driver Drill
Tukul Pemutar Skru Bergerudi
Tanpa Kord
充电式冲击螺丝起子电钻

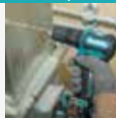

• Fast hammer drilling in masonry materials

Standard Equipment: Phillips Bit, Belt Clip

- DSME: 1x Speed Charger, 2x 4.0Ah Battery
- DSAE: 1x Speed Charger, 2x 2.0Ah Battery
- DZ: Without Charger, Battery & Carrying Case



Capacity Kapasiti 能力	Steel: 10mm (3/8") Wood: 28mm (1-1/8") Masonry: 8mm (5/16")
Chuck capacity Kapasiti Chuck 夹头能力	0.8 - 10mm (1/32 - 3/8")
Impacts Per Minute (IPM) Impak Per Minit 冲击数	High: 0 - 22,500 Low: 0 - 6,750
No Load Speed (RPM) Kelajuan Tanpa Beban 回转数	High: 0 - 1,500 Low: 0 - 450
Max Fastening Torque Maksimum Tenaga Pemutaran Pengancing 最大紧固扭力	Hard: 35N-m (310in.lbs.) Soft: 21N-m (190in.lbs.)
Max Lock Torque Pemutaran Tenaga Maksimum 最大锁紧扭力	32N-m (280in.lbs.)
Dimensions (L x W x H) Dimensi 体积	168x66x217mm (6-5/8"x2-5/8"x8-1/2")
Net Weight Berat Bersih 净重	1.1 - 1.3kg (2.4 - 2.8lbs)
Work Amount (approx.) Jumlah Kerja 工作量	460 holes with BL1021B Drilling ø9mm Auger Bit, Melapi 30mm Thickness

HP333DSME | HP333DWAE | HP333DWYE | HP333DWY | HP333DZ 10mm (3/8")

Cordless Hammer Driver Drill
Tukul Pemutar Skru Bergerudi
Tanpa Kord
充电式冲击螺丝起子电钻



• Increased motor power for higher speed and max tightening torque

Standard Equipment: Phillips Bit, Belt Clip

- DSME: 1x Speed Charger, 2x 4.0Ah Battery
- DWAE: 1x Standard Charger, 2x 2.0Ah Battery
- DWYE: 1x Standard Charger, 2x 1.5Ah Battery
- DWY: 1x Standard Charger, 1x 1.5Ah Battery
- DZ: Without Charger, Battery & Carrying Case



Capacity Kapasiti 能力	Steel: 10mm (3/8") Wood: 21mm (13/16") Masonry: 8mm (5/16")
Chuck Capacity Kapasiti Chuck 夹头能力	0.8 - 10mm (1/32 - 3/8")
Impacts Per Minute (IPM) Impak Per Minit 冲击数	High: 0 - 25,500 Low: 0 - 6,750
No Load Speed (RPM) Kelajuan Tanpa Beban 回转数	High: 0 - 1,700 Low: 0 - 450
Max Fastening Torque Maksimum Tenaga Pemutaran Pengancing 最大紧固扭力	Hard: 30N-m (270in.lbs.) Soft: 14N-m (130in.lbs.)
Max Lock Torque Pemutaran Tenaga Maksimum 最大锁紧扭力	28N-m (250 in.lbs.)
Dimensions (L x W x H) Dimensi 体积	193x66x212mm (7-5/8"x2-5/8"x8-3/8")
Net Weight Berat Bersih 净重	1.1 - 1.3kg (2.4 - 2.9lbs.)
Work Amount (approx.) Jumlah Kerja 工作量	350 holes with BL1021B Drilling ø9mm Auger Bit, Melapi 30mm Thickness

HP331DSME | HP331DWAE | HP331DWYE 10mm (3/8")

Cordless Hammer Driver Drill
Tukul Pemutar Skru Bergerudi
Tanpa Kord
充电式冲击螺丝起子电钻



• High speed mode for speedy drilling

Standard Equipment: Phillips Bit, Belt Clip

- DSME: 1x Speed Charger, 2x 4.0Ah Battery
- DWAE: 1x Standard Charger, 2x 2.0Ah Battery
- DWYE: 1x Standard Charger, 2x 1.5Ah Battery



Capacity Kapasiti 能力	Steel: 10mm (3/8") Wood: 21mm (13/16") Masonry: 8mm (5/16")
Impacts Per Minute (IPM) Impak Per Minit 冲击数	High: 0 - 25,500 Low: 0 - 6,750
No Load Speed (RPM) Kelajuan Tanpa Beban 回转数	High: 0 - 1,700 Low: 0 - 450
Max Fastening Torque Maksimum Tenaga Pemutaran Pengancing 最大紧固扭力	Hard: 30N-m (270in.lbs.) Soft: 14N-m (130in.lbs.)
Max Lock Torque Pemutaran Tenaga Maksimum 最大锁紧扭力	28N-m (250in.lbs.)
Dimensions (L x W x H) Dimensi 体积	201x66x209mm (7-7/8"x2-5/8"x8-1/4")
Net Weight Berat Bersih 净重	1.1 - 1.3kg (2.5 - 2.9lbs)
Work Amount (approx.) Jumlah Kerja 工作量	350 holes with BL1021B Drilling ø9mm Auger Bit, Melapi 30mm Thickness

* All list price shown are for reference only (exclude SST).

* Semua harga yang ditunjukkan adalah untuk rujukan sahaja (tidak termasuk SST). 所有显示的建议零售价仅供参考 (不包括SST)。

Cordless
Targeted Jobs

LED Flashlight
Lampu Saku LED
LED手电筒

Vacuum Cleaner
Pembersih Vakuum
吸尘器

Drilling / Fastening
Gerudi / Pengancing
钻孔 / 紧固

Impact Drilling / Demolition
Gerudi / Pembongkaran
冲击钻孔 / 拆墙施工

Cutting
Pemotong
切割

Grinding / Sanding
Pengkilan / Pemoles
打磨 / 砂磨

Sawing
Gergaji
锯切

Planing / Routing
Pengkilan / Tangkapan
刨削 / 压花

Others
Lain-lain
其他

Outdoor Power Equipment
Alatan Kuasa Luar
园机/户外

Makita
100 YEARS

12V_{max}

CXT

Li-ion Ah 4.0 2.0 1.5

TD111DSME | TD111DWAE | TD111DWYE | TD111DZ

Cordless Impact Driver
Pemutar Skru Impak Tanpa Kord
充电式冲击螺丝起子机



- 3-Mode operation: A-mode/ Hard mode/ Soft mode

Standard Equipment: Phillips Bit, Belt Clip

- DSME: 1x Speed Charger, 2x 4.0Ah Battery
- DWAE: 1x Standard Charger, 2x 2.0Ah Battery
- DWYE: 1x Standard Charger, 2x 1.5Ah Battery
- DZ: Without Charger, Battery & Carrying Case



Capacity Kapasiti 能力	Machine Screw: M4 - M8mm (5/32" - 5/16") Standard Bolt: M5 - M14 (3/16" - 9/16")
	High Tensile Bolt: M5 - M12 (3/16" - 1/2")
	Coarse thread (in length): 22 - 90mm (7/8" - 3-1/2")
	6.35mm (1/4")
Hex Shank Batang Heksagon 六角柄	
No Load Speed (RPM) Kelajuan Tanpa Beban 回转数	Hard: 0 - 3,000 Soft: 0 - 1,300
Impacts Per Minute (IPM) Impak Per Minit 冲击数	Hard: 0 - 3,900 Soft: 0 - 1,600
Max Fastening Torque Maksimum Tenaga Pemutaran Pengancing 最大紧固扭力	135N-m (1,200in.lbs.)
Dimensions (L x W x H) Dimensi 体积	135x66x210mm (5-5/16"x2-5/8"x8-1/4")
Net Weight Berat Bersih 净重	0.97 - 1.1kg (2.1 - 2.5lbs)
Work Amount (approx.) Jumlah Kerja 工作量	340 pcs with BL1021B Coarse Thread Wood Screw 45mm (Melapi)

TD112DNZ

Cordless Impact Driver
Pemutar Skru Impak Tanpa Kord
充电式冲击螺丝起子机



- Enhanced impact mechanism achieved by enlarging the diameter of spindle and anvil

- DNZ: Without Charger & Battery



Capacity Kapasiti 能力	Standard Bolt: M5 - M14 (3/16" - 9/16") High Strength Bolt: M5 - M12 (3/16" - 1/2")
	6.35mm (1/4")
Hex Shank Batang Heksagon 六角柄	
No Load Speed (RPM) Kelajuan Tanpa Beban 回转数	Hard: 0 - 3,000 Soft: 0 - 2,000
Impacts Per Minute (IPM) Impak Per Minit 冲击数	Hard: 0 - 3,900 Soft: 0 - 3,300
Max Fastening Torque Tenaga Pemutaran Pengancing Maksimum 最大紧固扭力	Hard: 135N-m Soft: 80N-m
Dimensions (L x W x H) Dimensi 体积	145x64x221mm (5-3/4"x2-1/2"x8-3/4")
Net Weight Berat Bersih 净重	0.99 - 1.2kg (2.2 - 2.6lbs.)

TD110DSME | TD110DWAE | TD110DWYE | TD110DZ

Cordless Impact Driver
Pemutar Skru Impak Tanpa Kord
充电式冲击螺丝起子机



- Compact and Lightweight

Standard Equipment: Phillips Bit, Belt Clip

- DSME: 1x Speed Charger, 2x 4.0Ah Battery
- DWAE: 1x Standard Charger, 2x 2.0Ah Battery
- DWYE: 1x Standard Charger, 2x 1.5Ah Battery
- DZ: Without Charger, Battery & Carrying Case



Capacity Kapasiti 能力	Machine Screw: M4 - M8mm (5/32" - 5/16") Standard Bolt: M5 - M12 (3/16" - 1/2")
	High Tensile Bolt: M5 - M10 (3/16" - 3/8")
	Coarse thread (in length): 22 - 90mm (7/8" - 3-1/2")
	6.35mm (1/4")
Hex Shank Batang Heksagon 六角柄	
No Load Speed (RPM) Kelajuan Tanpa Beban 回转数	0 - 2,600
Impacts Per Minute (IPM) Impak Per Minit 冲击数	0 - 3,500
Max Fastening Torque Maksimum Tenaga Pemutaran Pengancing 最大紧固扭力	110N-m (970in.lbs.)
Dimensions (L x W x H) Dimensi 体积	153x66x204mm (6"x2-5/8"x8-1/8")
Net Weight Berat Bersih 净重	1.0 - 1.2kg (2.3 - 2.6lbs)
Work Amount (approx.) Jumlah Kerja 工作量	250 pcs with BL1021B Coarse Thread Wood Screw 45mm (Melapi)

TW161DSME | TW161DWAE | TW161DZ 12.7mm (1/2")

Cordless Impact Wrench
Perengkuh Impak Tanpa Kord
充电式冲击套筒扳手

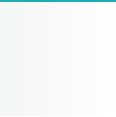

- Reverse Rotation Auto-Stop Mode stops in 0.2 seconds after loosened enough

Standard Equipment: Belt Clip

- DSME: 1x Speed Charger, 2x 4.0Ah Battery
- DWAE: 1x Standard Charger, 2x 2.0Ah Battery
- DZ: Without Charger, Battery & Carrying Case



Fastening Capacities Keupayaan Pengancing 紧固能力	Standard Bolt: M8 - M16 (5/16" - 5/8") High Tensile Bolt: M6 - M12 (1/4" - 1/2")
Square Drive Batang Segi Empat 四方头	12.7mm (1/2")
No Load Speed (RPM) Kelajuan Tanpa Beban 回转数	Hard: 0 - 2,400 Soft: 0 - 1,300
Impacts Per Minute (IPM) Impak Per Minit 冲击数	Hard: 0 - 3,600 Soft: 0 - 2,000
Max Fastening Torque Maksimum Tenaga Pemutaran Pengancing 最大紧固扭力	165N-m (122ft.lbs.)
Dimensions (L x W x H) Dimensi 体积	150x66x213mm (5-7/8"x2-5/8"x8-3/8")
Net Weight Berat Bersih 净重	1.1 - 1.2kg (2.4 - 2.7lbs.)

TW160DZ 9.5mm (3/8")

Cordless Impact Wrench
Perengkuh Impak Tanpa Kord
充电式冲击套筒扳手



- 9.5mm (3/8") square drive fits most common automotive sockets

Standard Equipment: Belt Clip

- DZ: Without Charger & Battery



Fastening Capacities Keupayaan Pengancing 紧固能力	Standard Bolt: M8 - M16 (5/16" - 5/8") High Tensile Bolt: M6 - M12 (1/4" - 1/2")
Square Drive Batang Segi Empat 四方头	9.5mm (3/8")
No Load Speed (RPM) Kelajuan Tanpa Beban 回转数	Hard: 0 - 2,400 Soft: 0 - 1,300
Impacts Per Minute (IPM) Impak Per Minit 冲击数	Hard: 0 - 3,600 Soft: 0 - 2,000
Max Fastening Torque Maksimum Tenaga Pemutaran Pengancing 最大紧固扭力	160N-m (120ft.lbs.)
Dimensions (L x W x H) Dimensi 体积	144x66x213mm (5-5/8"x2-5/8"x8-3/8")
Net Weight Berat Bersih 净重	1.0 - 1.2kg (2.2 - 2.6lbs.)

* All list price shown are for reference only (exclude SST).

* Semua harga yang ditunjukkan adalah untuk rujukan sahaja (tidak termasuk SST). 所有显示的建议零售价仅供参考 (不包括SST)。

Cordless Target Kord 无绳
LED Flashlight Lampu Suluh LED LED 手电筒
Vacuum Cleaner Pembersih VAKUUM 吸尘器
Drilling / Fastening Druai / Pengikat 钻 / 紧固
Impact Drilling / Demolition Druai / Penanggal 冲击钻 / 拆除加工
Cutting Pemotong 切割
Grinding / Sanding Pengisar / Piskin 磨削 / 打磨
Sawing Gergaji 电锯
Planing / Routing Pengisar / Tangkai 刨削 / 雕刻
Others Lain-lain 其他
Outdoor Power Equipment Alatan Kerja Luar 户外-户外
Makita



TW141DSME | TW141DWAЕ | TW141DZ 12.7mm (1/2")

Cordless Impact Wrench
Perengkuh Impak Tanpa Kord
充电式冲击套筒扳手



- Ultra compact design and lightweight

Standard Equipment: Belt Clip

- DSME: 1x Speed Charger, 2x 4.0Ah Battery
- DWAE: 1x Standard Charger, 2x 2.0Ah Battery
- DZ: Without Charger, Battery & Carrying Case



Fastening Capacities Keupayaan Pengancing 紧固能力	Standard Bolt: M8 - M16 (5/16" - 5/8") High Tensile Bolt: M6 - M12 (1/4" - 1/2")
Square Drive Batang Segi Empat 四方头	12.7mm (1/2")
No Load Speed (RPM) Kelajuan Tanpa Beban 回转数	0 - 2,600
Impacts Per Minute (IPM) Impak Per Minit 冲击数	0 - 3,200
Max Fastening Torque Maksimum Tenaga Pemutaran Pengancing 最大紧固扭力	145N·m (107ft.lbs.)
Dimensions (L x W x H) Dimensi 体积	168x66x205mm (6-5/8"x2-5/8"x8-1/8")
Net Weight Berat Bersih 净重	1.1 - 1.2kg (2.4 - 2.7lbs.)

TW140DZ 9.5mm (3/8")

Cordless Impact Wrench
Perengkuh Impak Tanpa Kord
充电式冲击套筒扳手



- 9.5mm (3/8") square drive fits most common automotive sockets

Standard Equipment: Belt Clip

- DZ: Without Charger & Battery



Fastening Capacities Keupayaan Pengancing 紧固能力	Standard Bolt: M8 - M16 (5/16" - 5/8") High Tensile Bolt: M6 - M12 (1/4" - 1/2")
Square Drive Batang Segi Empat 四方头	9.5mm (3/8")
No Load Speed (RPM) Kelajuan Tanpa Beban 回转数	0 - 2,600
Impacts Per Minute (IPM) Impak Per Minit 冲击数	0 - 3,200
Max Fastening Torque Maksimum Tenaga Pemutaran Pengancing 最大紧固扭力	140N·m (1,240in.lbs.)
Dimensions (L x W x H) Dimensi 体积	161x66x205mm (6-3/8"x2-5/8"x8-1/8")
Net Weight Berat Bersih 净重	1 - 1.2kg (2.3 - 2.7lbs.)
Work Amount (approx.) Jumlah Kerja 工作量	160 pcs with BL1021B High Tensile Bolt M12 Standard Fastening Torque at 100N.m

TW060DZ 6.35mm (1/4")

Cordless Impact Wrench
Perengkuh Impak Tanpa Kord
充电式冲击套筒扳手



- Electric brake for increased operator safety

Standard Equipment: Belt Clip

- DZ: Without Charger & Battery



Fastening Capacities Keupayaan Pengancing 紧固能力	Standard Bolt: M8 - M12 (5/16" - 1/32") High Tensile Bolt: M6 - M10 (1/4" - 3/8")
Square Drive Batang Segi Empat 四方头	6.35mm (1/4")
No Load Speed (RPM) Kelajuan Tanpa Beban 回转数	0 - 2,600
Impacts Per Minute (IPM) Impak Per Minit 冲击数	0 - 3,200
Max Fastening Torque Maksimum Tenaga Pemutaran Pengancing 最大紧固扭力	60N·m (530in.lbs.)
Dimensions (L x W x H) Dimensi 体积	161x66x205mm (6-3/8"x2-5/8"x8-1/8")
Net Weight Berat Bersih 净重	1.0 - 1.2kg (2.2 - 2.6lbs.)

HR166DSMJ | HR166DWAJ | HR166DZ 16mm (5/8")

Cordless Rotary Hammer
Tukul Putar Tanpa Kord
充电式电钻



- 2-Mode operation for Rotation Only or Hammering with Rotation

Standard Equipment: Side Grip, Depth Gauge

- DSMJ: 1x Speed Charger, 2x 4.0Ah Battery, 1x Makpac Connector Box
- DWAJ: 1x Standard Charger, 2x 2.0Ah Battery, 1x Makpac Connector Box
- DZ: Without Charger, Battery & Carrying Case



Impact Energy Kekuatan Impak 单次最大锤击力	EPTA-Procedure 05/2009: 1.1J Our experimental conditions: 1.0J
Capacity Kapasiti 能力	Concrete: 16mm (5/8") Steel: 10mm (3/8") Wood: 13mm (1/2")
Impacts Per Minute (IPM) Impak Per Minit 冲击数	0 - 4,800
No Load Speed (RPM) Kelajuan Tanpa Beban 回转数	0 - 680
Dimensions (L x W x H) Dimensi 体积	BL1021B: 250x74x187mm (9-7/8"x2-15/16"x7-3/8")
Net Weight Berat Bersih 净重	1.8 - 2.4kg (4.1 - 5.4lbs)
Work Amount (approx.) Jumlah Kerja 工作量	42 holes with BL1021B Masonry drill ø6mm (Concrete 40N/ mm2 Depth 40mm)



VIDEO CLIP
Models and specs may vary by country

HR140DWYE1 14mm (9/16")

Cordless Rotary Hammer
Tukul Putar Tanpa Kord
充电式电钻



- 2-Mode operation for Rotation Only or Hammering with Rotation

Standard Equipment: Side Grip, Depth Gauge

- DWYE1: 1x Standard Charger, 2x 1.5Ah Battery, Accessories Set

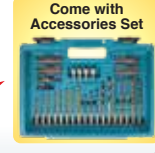

Impact Energy Kekuatan Impak 单次最大锤击力	EPTA-Procedure 05/2009: 1.0J Our experimental conditions: 0.9J
Capacity Kapasiti 能力	Concrete: 14mm (9/16") Steel: 10mm (3/8") Wood: 13mm (1/2")
Impacts Per Minute (IPM) Impak Per Minit 冲击数	0 - 4,900
No Load Speed (RPM) Kelajuan Tanpa Beban 回转数	0 - 850
Dimensions (L x W x H) Dimensi 体积	BL1021B: 246x74x179mm (9-11/16"x2-15/16"x7") BL1041B: 246x74x198mm (9-11/16"x2-15/16"x7-3/4")
Net Weight Berat Bersih 净重	1.9 - 2.6kg (4.3 - 5.6lbs)
Work Amount (approx.) Jumlah Kerja 工作量	32 holes with BL1021B Masonry drill ø6mm (Concrete 40N/ mm2 Depth 40mm)

* All list price shown are for reference only (exclude SST).

* Semua harga yang ditunjukkan adalah untuk rujukan sahaja (tidak termasuk SST). 所有显示的建议零售价仅供参考 (不包括SST)。

Cordless
Target Aplikasi

LED Flashlight
Lampu Suhu LED
LED照灯

Vacuum Cleaner
Penyedut Vakum
吸尘器

Drilling / Fastening
Gantuli / Pengancing
钻孔 / 紧固

Impact Drilling / Demolition
Gantuli / Penyah
冲击钻孔 / 拆毁

Cutting
Pemotong
切割

Grinding / Sanding
Pengamiran / Pencil
研磨 / 砂磨

Sawing
Gergaji
锯切

Planing / Routing
Pengayutan / Tangkapan
刨削 / 磨削

Others
Lain-lain
其他

Outdoor Power Equipment
Alatan Kuat Luar
园机/户外



12V_{max}

CXT

Li-ion Ah 4.0 2.0 1.5

WR100D Cordless Ratchet Wrench

LED job light

Switch lever

Forward / Reverse rotation change

Turn the reversing lever to the A side for clockwise rotation or to the B side for counterclockwise rotation

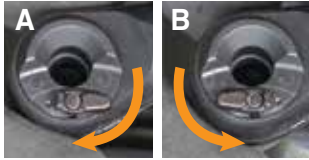

Compatible with variable sockets with socket adaptor



Accessories (Optional)



Socket Adaptor
9.5mm (3/8")
Part No.191A50-3

Socket Adaptor
6.35mm (1/4")
Part No.191A51-1

Standard Equipment



Tool Bag (optional)
Part No. 832071-7

Able to tighten 13mm nut onto M8 threaded rod



13mm nut only

WR100DWA | WR100DZ 9.5mm (3/8")

Cordless Ratchet Wrench

Perengkuh Ratchet Tanpa Kord
充电式棘轮扳手



- Supplied with Two Socket Adaptors for Compatibility with a Variety of Sockets

Standard Equipment:
Socket Adaptor 9.5mm & 6.35mm

- DWA: 1x Standard Charger, 1x 2.0Ah Battery, 1x Tool Bag
- DZ: Without Charger & Battery



Capacity Kapasiti 能力	Standard Bolt: M5 - M12 (3/16" - 1/2") High Tensile Bolt: M5 - M10 (3/16" - 3/8") 9.5mm (3/8") 6.35mm (1/4")
Square Drive Kepala Segi Empat 方形头	
No Load Speed (RPM) Kelajuan Tanpa Beban 回转数	0 - 800
Max Fastening Torque Tenaga Pemutaran Pengancing Maksimum 最大紧固扭力	47.5N·m (420in.lbs.)
Dimensions (L x W x H) Dimensi 体积	341x67x63mm (13-7/16"x2-5/8"x2-1/2")
Net Weight Berat Bersih 净重	1.0 - 1.2kg (2.3 - 2.7lbs.)

TL064DSME | TL064DWAE | TL064DZ

Cordless Angle Impact Driver

Pemutar Skru Impak Sudut
Tanpa Kord
充电式角向冲击螺丝起子机

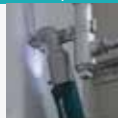

- Compact & lightweight for fastening and loosening in tight spaces

Standard Equipment: Phillips Bit, Belt Clip

- DSME: 1x Speed Charger, 2x 4.0Ah Battery
- DWAE: 1x Standard Charger, 2x 2.0Ah Battery
- DZ: Without Charger, Battery & Carrying Case



Capacity Kapasiti 能力	Machine Screw: M4 - M8 (5/32" - 5/16") Standard Bolt: M4 - M12 (5/32" - 1/2") High Tensile Bolt: M4 - M8 (5/32" - 5/16") Coarse thread (in length): 22 - 75mm (7/8" - 2-31/32") 6.35mm (1/4")
Hex Shank Batang Heksagon 六角柄	
No Load Speed (RPM) Kelajuan Tanpa Beban 回转数	0 - 2,000
Impacts Per Minute (IPM) Impak Per Minit 冲击数	0 - 3,000
Max Fastening Torque Maksimum Tenaga Pemutaran Pengancing 最大紧固扭力	60N·m (530in.lbs.)
Dimensions (L x W x H) Dimensi 体积	361x66x86mm (14-1/4"x2-5/8"x3-3/8")
Net Weight Berat Bersih 净重	1.2 - 1.6kg (2.7 - 3.6lbs)
Work Amount (approx.) Jumlah Kerja 工作量	933 pcs with BL1021B Machine Screw M8 x 16mm

TL065DSME | TL065DWAE | TL065DZ

Cordless Angle Impact Wrench

Perengkuh Impak Sudut
Tanpa Kord
充电式角向冲击套筒扳手



- Compact & lightweight for fastening and loosening in tight spaces

Standard Equipment: Belt Clip

- DSME: 1x Speed Charger, 2x 4.0Ah Battery
- DWAE: 1x Standard Charger, 2x 2.0Ah Battery
- DZ: Without Charger, Battery & Carrying Case



Capacity Kapasiti 能力	Standard Bolt: M4 - M12 (5/32" - 1/2") High Tensile Bolt: M4 - M8 (5/32" - 5/16") 9.5mm (3/8")
Square Drive Batang Segi Empat 四方头	
No Load Speed (RPM) Kelajuan Tanpa Beban 回转数	0 - 2,000
Impacts Per Minute (IPM) Impak Per Minit 冲击数	0 - 3,000
Max Fastening Torque Maksimum Tenaga Pemutaran Pengancing 最大紧固扭力	60N·m (530in.lbs.)
Dimensions (L x W x H) Dimensi 体积	361x66x86mm (14-1/4"x2-5/8"x3-3/8")
Net Weight Berat Bersih 净重	1.2 - 1.6kg (2.7 - 3.6lbs)
Work Amount (approx.) Jumlah Kerja 工作量	933 pcs with BL1021B Machine Screw M8 x 16mm

* All list price shown are for reference only (exclude SST).

* Semua harga yang ditunjukkan adalah untuk rujukan sahaja (tidak termasuk SST). 所有显示的建议零售价仅供参考 (不包括SST)。

Cordless
Tanpa Kord 无绳式

LED Flashlight
Lampu Suluh LED
LED 照明灯

Vacuum Cleaner
Pembersih Vakuum
吸尘器

Drilling / Fastening
Draib / Pengikat
钻孔 / 紧固

Impact Drilling / Demolition
Draib Impak / Hancurkan
冲击钻孔 / 拆除加工

Cutting
Pemotong
切割

Grinding / Sanding
Pengisar / Poles
磨削 / 打磨

Sawing
Gergaji
锯切

Planing / Routing
Program / Tampat
刨削 / 雕刻

Others
Lain-lain
其他

Outdoor Power Equipment
Alatan Kerja Luar
园具-户外



12V_{max}

CXT

Li-ion Ah 4.0 2.0 1.5

DA332DWA | DA332DZ 10mm (3/8")

Cordless Angle Drill
Gerudi Sudut Tanpa Kord
充电式角向电钻



- Up to 40% faster drilling and 380% longer runtime**



Standard Equipment: Chuck Key, Chuck Key Holder, Phillips Bit, Belt Clip

- DWAE: 1x Standard Charger, 2x 2.0Ah Battery
- DZ: Without Charger, Battery & Carrying Case



TM30DWA | TM30DWAEX1 | TM30DZ

Cordless Multi Tool
Mesin Pemotong Berbilang Fungsi
Tanpa Kord
充电式多功能切割打磨机



- 12 Angle settings at every 30° from 0° to 360°



Standard Equipment: Hex Wrench

- DWAE: 1x Standard Charger, 2x 2.0Ah Battery
- DWAEX1: 1x Standard Charger, 2x 2.0Ah Battery, Accessories Set (Plunge Cut Saw Blade 28 (B-21353), Segment Saw Blade 85 (B-21325), Sanding Pad (B-46202)
- DZ: Without Charger, Battery & Carrying Case



CP100DWA | CP100DZ

Cordless Multi Cutter
Pemotong Pelbagai Fungsi
Tanpa Kord
充电式多功能电剪



- Cuts thin and thick material up to 6mm such as cardboard, carpet, fabrics, leather, CD, DVD & Blu-ray



Standard Equipment: Blade

- DWA: 1x Standard Charger, 1x 2.0Ah Battery, Tool Bag
- DZ: Without Charger & Battery

Capacity Kapasiti 能力	Steel: 10mm (3/8") Wood: 12mm (1/2")
No Load Speed (RPM) Kelajuan Tanpa Beban 回转数	0 - 1,100
Head Height Ketinggian Kepala 高度	63mm (2-1/2")
Center Height Pusat Tinggi 中心高度	23.5mm (15/16")
Dimensions (L x W x H) Dimensi 体积	BL1021B: 313x68x86mm (12-3/8"x2-11/16"x3-3/8") BL1041B: 332x68x86mm (13-1/8"x2-11/16"x3-3/8")
Net Weight Berat Bersih 淨重	1.2 - 1.3kg (2.6 - 2.9lbs)
Work Amount (approx.) Jumlah Kerja 工作量	600 pcs with BL1021B Wood Screw ø4.1 x 38mm

Oscillations Per Minute (OPM) Kelajuan Ayunan 摆动速度	6,000 - 20,000
Oscillation Angle Sudut Ayunan 摆动角度	Left: 1.6° Right: 1.6° Total: 3.2°
Dimensions (L x W x H) Dimensi 体积	277x65x98mm (10-7/8"x2-9/16"x3-7/8")
Net Weight Berat Bersih 淨重	1.1 - 1.3kg (2.3 - 2.9lbs)
Continuous Usage Time (approx.) Masa Penggunaan Berterusan 连续使用时间	16 min with BL1021B

Max Cutting Capacity Kapasiti Pemotongan Maksimum 最大切割能力	6mm (1/4")
No Load Speed (RPM) Kelajuan Tanpa Beban 回转数	300
Dimensions (L x W x H) Dimensi 体积	BL1021B: 272x66x120mm (10-3/4"x2-5/8"x4-3/4") BL1041B: 291x66x121mm (11-1/2"x2-5/8"x4-3/4")
Net Weight Berat Bersih 淨重	0.72 - 0.88kg (1.6 - 1.9lbs)
Work Amount (approx.) Jumlah Kerja 工作量	800 m with BL1021B Cardboard Carton 5mm (T) 500mm (L)



SC103D
Cordless Threaded Rod Cutter
充电式螺纹杆切割机

Reversing switch lever



Clean cut surface
Burr-free cuts allow for easy nut tightening

Lightweight
2.8kg
with BL1041B
4.0Ah Battery



Compact motor section with overall length of
177mm

Maximum Cutting Capacity
Mild Steel:
M10
Stainless Steel:
W3/8

SC103DZJ

Cordless Threaded Rod Cutter
Pemotong Batang Keluli Tanpa Kord
充电式螺纹杆切割机



- More Compact & High Productivity



Standard Equipment: Cutter Blade W3/8 (199081-0), Hex Socket Head Bolt, Blade Cover, Depth Gauge, Thumb Screw, Hex Wrench

- DZJ: With 1x Makpac Connector Box, Without Charger & Battery

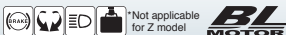

Max Cutting Capacity Kapasiti Pemotongan Maksimum 最大切割能力	Mild Steel: M10 Stainless Steel: W3/8
Min. Cutting Length Panjang Pemotongan Minimum 最小切割长度	20mm (13/16")
Dimensions (L x W x H) Dimensi 体积	180x107x289mm (7-1/8"x4-1/4"x11-3/8")
Net Weight Berat Bersih 淨重	2.7 - 2.8kg (6.0 - 6.2lbs.)
Work Amount (approx.) Jumlah Kerja 工作量	550 pcs with BL1041B Mild Steel M10

* All list price shown are for reference only (exclude SST).

* Semua harga yang ditunjukkan adalah untuk rujukan sahaja (tidak termasuk SST). 所有显示的建议零售价仅供参考 (不包括SST)。

Cordless
Target: No Cord

LED Flashlight
Lampu Suli LED
LED照灯

Vacuum Cleaner
Pembersih Vakum
吸尘器

Drilling / Fastening
Gerudi / Pengikat
钻孔 / 紧固

Impact Drilling / Demolition
Gerudi / Hancurkan
冲击钻孔 / 拆毁

Cutting
Memotong
切割

Grinding / Sanding
Pengkilan / Pemoles
打磨 / 砂磨

Sawing
Gergaji
锯切

Planing / Routing
Pergaliran / Tumpang
刨削 / 压边

Others
Lain-lain
其他

Outdoor Power Equipment
Alatan Kuat Luar
园机/户外

Makita
MAKITA



PV301DZ

Cordless Sander Polisher
Penggilap Tanpa Kord
充电式打蜡抛光机



- Easy to change Hook & Loop style backing pad mainly for polishing

Standard Equipment: Side Grip, Pad 75 (743125-4), Pad 50 (743124-6), Adapter (743128-2), Sponge Pad Rough (191N90-9), Sponge Pad Medium (191N91-7), Wool Pad (191N92-5)

- DZ: Without Charger & Battery



Pad / Disc Diameter Diameter Pad / Cakera 垫/盘直径	Hook & Loop Style: 80mm (3-1/8") Twist-On / Twist-Off Style: 50mm (2")
Backing Pad Diameter Diameter Pad 衬垫直径	Hook & Loop Style: 75mm (2-15/16") Twist-On / Twist-Off Style: 46mm (1-13/16")
Head Length Panjang Kepala 头长度	127mm (5")
No Load Speed (RPM) Kelajuan Tanpa Beban 回转速数	Polishing: 0 - 2,800 Sanding: 0 - 9,500
Dimensions (L x W x H) Dimensi 体积	137x67x231mm (5-3/8x2-5/8x9-1/8")
Net Weight Berat Bersih 净重	1.1 - 1.2kg (2.4 - 2.6lbs.)
Continuous Usage Time (approx.) Masa Penggunaan Berterusan 连续使用时间	18 min with BL1041B

CC301DWME | CC301DWAE | CC301DZ 85mm (3-3/8")

Cordless Cutter
Pemotong Tanpa Kord
充电式切割机



- Designed for cutting glass and ceramic tile

Standard Equipment: Diamond Wheel, Water Supply Tank Assembly, Hex Wrench

- DWME: 1x Standard Charger, 2x 4.0Ah Battery
- DWAE: 1x Standard Charger, 2x 2.0Ah Battery
- DZ: Without Charger, Battery & Carrying Case



Blade Diameter Diameter Bilah 锯片直径	85mm (3-3/8")
Max Cutting Capacity Kapasiti Pemotongan Maksimum 最大切割能力	90°: 25.5mm (1") 45°: 16.5mm (5/8")
No Load Speed (RPM) Kelajuan Tanpa Beban 回转速数	1,600
Tank Capacity Kapasiti Tangki 水箱容量	Water : 0.5L
Dimensions (L x W x H) Dimensi 体积	313x170x125mm (12-3/8"x6-11/16"x4-7/8")
Net Weight Berat Bersih 净重	1.9kg (4.1lbs)
Work Amount (approx.) Jumlah Kerja 工作量	1.5 pcs with BL1021B Diamond Blade, Glass 10 x 300mm

HS301DSME | HS301DWAE | HS301DZ 85mm (3-3/8")

Cordless Circular Saw
Gergaji Piring Tanpa Kord
充电式圆锯



- Fast cutting of plywood, MDF, pegboard, particleboard, melamine, drywall and more

Standard Equipment: TCT Saw Blade (B-14607), Hex Wrench

- DSME: 1x Speed Charger, 2x 4.0Ah Battery
- DWAE: 1x Standard Charger, 2x 2.0Ah Battery
- DZ: Without Charger, Battery & Carrying Case

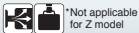

Blade Diameter Diameter Bilah 锯片直径	85mm (3-3/8")
Max Cutting Capacity Kapasiti Pemotongan Maksimum 最大切割能力	90°: 25.5mm (1") 45°: 16.5mm (5/8")
No Load Speed (RPM) Kelajuan Tanpa Beban 回转速数	1,500
Dimensions (L x W x H) Dimensi 体积	313x170x155mm (12-3/8"x6-11/16"x6-1/8")
Net Weight Berat Bersih 净重	1.6 - 1.7kg (3.5 - 3.8lbs)
Work Amount (approx.) Jumlah Kerja 工作量	140 cuts with BL1021B Sawing (SPF 1"x4" 0 Degree Cut)

SD100DWAJ | SD100DZ

Cordless Drywall Saw
Gergaji Drywall Tanpa Kord
充电式石膏板切割机



- Ideal for cutting holes in drywalls when setting ceiling lights, air vents etc

Standard Equipment: Blade, Blade Cover, Base Cover, Hex Wrench

- DWAJ: 1x Standard Charger, 2x 2.0Ah Battery, 1x Makpac Connector Box
- DZ: Without Charger, Battery & Carrying Case



Strokes Per Minute (SPM) Kelajuan Strok 冲程速度	0 - 6,000
Length of Stroke Panjang Strok 冲程长度	6mm (1/4")
Capacity Kapasiti 能力	Drywall: 30mm (1-3/16") Wood: 15mm (9/16")
Dimensions (L x W x H) Dimensi 体积	239x79x266mm (9-3/8"x3-1/8"x10-1/2")
Net Weight Berat Bersih 净重	1.4 - 1.6kg (3.2 - 3.5lbs)
Work Amount (approx.) Jumlah Kerja 工作量	50 m with BL1021B Cutting (Gypsum Board Thickness 9.5mm/ 2ply)

JV101DWAE | JV101DWYE | JV101DZ

Cordless Jig Saw
Gergaji Jig Tanpa Kord
充电式线锯机



- Aluminum die-cast base adjusts from 0°-45° right to left

Standard Equipment: Jig Saw Blade B-10 (A-85628), Hex Wrench

- DWAE: 1x Standard Charger, 2x 2.0Ah Battery
- DWYE: 1x Standard Charger, 2x 1.5Ah Battery
- DZ: Without Charger, Battery & Carrying Case



Max Cutting Capacity at 90° Kapasiti Pemotongan Maksimum 最大切割能力	Wood: 65mm (2-9/16") Aluminum: 4mm (5/32") Mild Steel: 2mm (1/16")
Length of Stroke Panjang Strok 冲程长度	18mm (11/16")
Strokes Per Minute (SPM) Kelajuan Strok 冲程速度	0-2,900
Dimensions (L x W x H) Dimensi 体积	232x76x196mm (9-1/8"x3"x7-3/4")
Net Weight Berat Bersih 净重	1.8 - 1.9kg (3.9 - 4.3lbs)
Work Amount (approx.) Jumlah Kerja 工作量	60 pcs with BL1021B Sawing (Plywood 300mm Long x 12mm thickness)

* All list price shown are for reference only (exclude SST).

* Semua harga yang ditunjukkan adalah untuk rujukan sahaja (tidak termasuk SST). 所有显示的建议零售价仅供参考 (不包括SST)。

Cordless
Tanpa Kord 无线式

LED Flashlight
Lampu Suluh LED
LED 手电筒

Vacuum Cleaner
Pembersih Vakuum
吸尘器

Drilling / Fastening
Drauli / Pengikat
钻孔 / 紧固

Impact Drilling / Demolition
Drauli / Penembak
起工钻孔 / 拆墙加工

Cutting
Pemotong
切割

Grinding / Sanding
Pengisar / Pasir
磨削 / 打磨

Sawing
Gergaji
锯切

Planing / Routing
Pengisar / Tampam
刨削 / 雕刻

Others
Lain-lain
其他

Outdoor Power Equipment
Alatan Kerja Luar
园具-户外



12V_{max}

CXT

Li-ion Ah 4.0 2.0 1.5

JV103DSMJ | JV103DWAJ | JV103DZ

Cordless Jig Saw
Gergaji Jig Tanpa Kord
充电式线锯机



• Up to 2.2X Faster Cutting & 2.2X Longer Runtime*

- Standard Equipment:**
Jig Saw Blade B-10 (A-85628), Hex Wrench
- DSMJ: 1x Speed Charger, 2x 4.0Ah Battery, 1x Makpac Connector Box
 - DWAJ: 1x Standard Charger, 2x 2.0Ah Battery, 1x Makpac Connector Box
 - DZ: Without Charger, Battery & Carrying Case



VIDEO CLIP
Models and specs may vary by country



Max Cutting Capacity at 90° Kapasiti Pemotongan Maksimum 最大切割能力	Wood: 90mm (3-1/2") Aluminum: 20mm (13/16") Mild Steel: 10mm (3/8")
Length of Stroke Panjang Strok 冲程长度	23mm (7/8")
Strokes Per Minute (SPM) Kelajuan Strok 冲程速度	800 - 3,000
Dimensions (L x W x H) Dimensi 体积	237x76x206mm (9-3/8"x3"x8-1/8")
Net Weight Berat Bersih 净重	1.9 - 2.0kg (4.1 - 4.4lbs)
Work Amount (approx.) Jumlah Kerja 工作量	90 pcs with BL1021B Sawing (Plywood 300mm Long x 12mm thickness)

JV102DZ

Cordless Jig Saw
Gergaji Jig Tanpa Kord
充电式线锯机



• Up to 2.2X Faster Cutting & 2.2X Longer Runtime*

- Standard Equipment:**
Jig Saw Blade B-10 (A-85628), Hex Wrench
- DZ: Without Charger & Battery



VIDEO CLIP
Models and specs may vary by country



Max Cutting Capacity at 90° Kapasiti Pemotongan Maksimum 最大切割能力	Wood: 90mm (3-1/2") Aluminum: 20mm (13/16") Mild Steel: 10mm (3/8")
Length of Stroke Panjang Strok 冲程长度	23mm (7/8")
Strokes Per Minute (SPM) Kelajuan Strok 冲程速度	800 - 3,000
Dimensions (L x W x H) Dimensi 体积	237x76x186mm (9-3/8"x3"x7-3/8")
Net Weight Berat Bersih 净重	1.8 - 1.9kg (3.9 - 4.2lbs)
Work Amount (approx.) Jumlah Kerja 工作量	290 pcs with BL1021B Sawing (Plywood 300mm Long x 12mm thickness)

PT354DZ

Cordless Pin Nailer
Mesin Pemaku Tanpa Kord
充电式打钉机



• Ergonomically designed handle with soft grip provides increased comfort

- Standard Equipment:** Nose Adapter, Safety Goggles, Belt Clip, Hex Wrench
- DZ: Without Charger & Battery



Capacity Kapasiti 能力	Length: 15, 18, 25, 30, 35mm (5/8", 11/16", 1", 1-3/16", 1-3/8") Dia.: 0.6mm (1/32") Gauge: 23Ga		
Magazine Capacity Bilangan Staples 装订个数	120		
Dimensions (L x W x H) Dimensi 体积	231x66x226mm (9-1/8"x2-5/8"x8-7/8")		
Net Weight Berat Bersih 净重	1.8 - 2.0kg (4.0 - 4.4lbs)		
Work Amount (approx.) Jumlah Kerja 工作量	1333 pcs with BL1021B Pin nail		
Accessories (optional)			
Description	Size	Pcs/ Box	Part No.
Pin Nail 18mm (11/16")	P18	10,000	F-31825
Pin Nail 25mm (1")	P25	10,000	F-31838
Pin Nail 30mm (1-3/16")	P30	10,000	F-31841
Pin Nail 35mm (1-3/8")	P35	10,000	F-31854

CG100DZA

Cordless Caulking Gun
Alat Tembak Silikon Tanpa Kord
充电式填缝枪



• 5 Speed dial optimizes flow rate 0 - 28mm/sec

- Standard Equipment:** Holder, Holder Joint, Piston, Rack 42, Safety Goggles
- DZA: Without Charger & Battery



VIDEO CLIP
Models and specs may vary by country

Max Dispersing Force Tujahan Maksimum 最大推力	5,000N (1,100lbs)
No Load Speed Kelajuan Tanpa Beban 回转数	0 - 28mm/sec. (0 - 66in./min.)
Holder Size Kapasiti 容量	300mL (Optional Accessories 600mL, 800mL Holder)
Dimensions (L x W x H) Dimensi 体积	404x108x259mm (15-7/8"x4-1/4"x10-1/4")
Net Weight Berat Bersih 净重	1.9 - 2.6kg (4.2 - 5.8lbs)
Work Amount (approx.) Jumlah Kerja 工作量	150 pcs with BL1016 300ml silicon sealant

JR105DWAJ | JR105DZ

Cordless Recipro Saw
Gergaji Resipro Tanpa Kord
充电式往复锯



• Cuts PVC, ABS pipe, EMT, drywall, wood & more

- Standard Equipment:** Hex Wrench, Recipro Saw Blades 2pcs (B-20404 & B-20432)
- DWAE: 1x Standard Charger, 2x 2.0Ah Battery
 - DZ: Without Charger, Battery & Carrying Case



Length of Stroke Panjang Strok 冲程长度	13mm (1/2")
Strokes Per Minute (SPM) Kelajuan Strok 冲程速度	0 - 3,300
Capacity Kapasiti 能力	Pipe: 50mm (2") Wood: 50mm (2")
Dimensions (L x W x H) Dimensi 体积	376x66x186mm (14-3/4"x2-5/8"x7-3/8")
Net Weight Berat Bersih 净重	1.3 - 1.5kg (2.9 - 3.2lbs)
Work Amount (approx.) Jumlah Kerja 工作量	45 pcs with BL1021B Cutting (PVC plastic hose 48mm)

* All list price shown are for reference only (exclude SST).
* Semua harga yang ditunjukkan adalah untuk rujukan sahaja (tidak termasuk SST). 所有显示的建议零售价仅供参考 (不包括SST)。

Cordless
Target: Wood, Metal

LED Flashlight
Lampu Saku LED
LED手电筒

Vacuum Cleaner
Pembersih Vakuum
吸尘器

Drilling / Fastening
Gergaji / Pengikat
钻孔 / 紧固

Impact Drilling / Demolition
Gergaji / Pemusnah
冲击钻孔 / 拆除施工

Cutting / Sanding
Pangkas / Gergaji
切割 / 砂磨

Grinding / Sanding
Pangkas / Gergaji
砂磨 / 砂磨

Sawing / Gouging
Gergaji
锯切

Planing / Routing
Pangkas / Tanggapan
刨削 / 压花

Others
Lain-lain
其他

Outdoor Power Equipment
Alatan Kerja Luar
园具/户外

Others
Lain-lain
其他

Others
Lain-lain
其他

Others
Lain-lain
其他



UR100DSME | UR100DZ

Cordless Grass Trimmer
Pemotong Rumput tanpa Kord
充电式割草机



- Well balanced design with fully adjustable features to suit any operator

Standard Equipment: Band Assembly, Nylon Cutting Head (198853-0), Nylon Cord, Accessory Bag, Hex Wrench

- DSME: 1x Speed Charger, 2x 4.0Ah Battery
- DZ: Without Charger & Battery



Cutting Width Lebar Keratan 切割宽度	Nylon Cutting Head: 260mm (10") Plastic Blade: 230mm (9")
No Load Speed (RPM) Kelajuan Tanpa Beban 回转数	Nylon Cutting Head: 9,000 Plastic Blade: 10,000
Spindle Size Saiz Spindel 主轴尺寸	M8 x 1.25RH
Dimensions (L x W x H) Dimensi 体积	835 - 1,185x267x210 - 315mm (32-7/8 - 46-2/3"x10-1/2"x8-1/4 - 12-1/3")
Net Weight Berat Bersih 淨重	2.1 - 2.3kg (4.4 - 4.9lbs.)
Continuous Usage Time (approx.) Masa Penggunaan Berterusan 连续使用时间	27 min with BL1021B

UH353DWA | UH353DZ 350mm (13-3/4")

Cordless Hedge Trimmer
Pemangkas Tanaman Pagar
Tanpa Kord
充电式篱笆修剪机

- Lightweight. Low Vibration. Low Noise

Standard Equipment: Blade Cover

- DWA: 1x Standard Charger, 1x 2.0Ah Battery
- DZ: Without Charger & Battery



Blade Length Panjang bilah 刀片长度	350mm (13-3/4")
Tooth Spacing Selang Gigi 牙齿间隔	28mm (1-1/8")
Max Cutting Capacity Kapasiti Pemotongan Maksimum 最大切割能力	15mm (9/16")
Strokes Per Minute (SPM) Kelajuan Strok 冲程速度	3,300
Dimensions (L x W x H) Dimensi 体积	693x175x165mm (27-1/4"x6-7/8"x6-1/2")
Net Weight Berat Bersih 淨重	1.9 - 2.1 kg (4.2 - 4.5 lbs.)
Continuous Usage Time (approx.) Masa Penggunaan Berterusan 连续使用时间	40 min with BL1021B

UN460WDZ

Cordless Pole Hedge Trimmer
Pemangkas Tanaman Pagar
Tinggi Tanpa Kord
充电式高枝篱笆树剪

- High cutting speed enables smooth and efficient trimming

Standard Equipment:
Blade Cover

- DZ: Without Charger & Battery

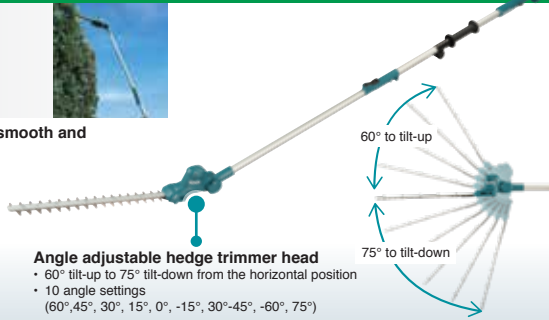

Blade Length Panjang Bilah 刀片长度	460mm (18-1/8")
Strokes Per Minute (SPM) Kelajuan Strok 冲程速度	3,600
Tooth Spacing Selang Gigi 牙齿间隔	28mm (1-1/8")
Max Cutting Capacity Kapasiti Pemotongan Maksimum 最大切割能力	18mm (11/16")
Dimensions (L x W x H) Dimensi 体积	1,889-2,511x87x134mm (74-1/2"-99x3-7/16x5-1/4")
Net Weight Berat Bersih 淨重	2.8 - 3.0kg (6.2 - 6.6lbs.)
Continuous Usage Time (approx.) Masa Penggunaan Berterusan 连续使用时间	53 min with BL1041B

UH201DWAX | UH201DZ 200mm (7-7/8")

Cordless Hedge Trimmer
Pemangkas Tanaman Pagar
Tanpa Kord
充电式篱笆修剪机

- Dual blade action cuts quickly with a shearing effect

Standard Equipment: Blade Cover (458342-0), Chip Receiver (198401-5)

- DWAX: 1x Standard Charger, 1x 2.0Ah Battery, 1x Grass Shear Blade (195267-4), 1x Grass Receiver (457426-1)
- DZ: Without Charger & Battery

For UH201DWAX only



Blade Length Panjang Bilah 刀片长度	200mm (7-7/8")
Tooth Spacing Selang Gigi 牙齿间隔	26mm (1")
Strokes Per Minute (SPM) Kelajuan Strok 冲程速度	2,500
Dimensions (L x W x H) Dimensi 体积	504x120x131mm (19-7/8"x4-3/4"x5-1/8")
Net Weight Berat Bersih 淨重	1.3 - 1.5kg (2.8 - 3.3lbs)
Continuous Usage Time (approx.) Masa Penggunaan Berterusan 连续使用时间	45 min with BL1021B

UM600DWA | UM600DZ 160mm (6-5/16")

Cordless Grass Shear
Pemotong Rumput Tanpa Kord
充电式割草机

- 2 in 1: Both trimmer blade and shear blade can be attached

Standard Equipment: Grass Receiver, Blade Cover

- DWA: 1x Standard Charger, 1x 2.0Ah Battery
- DZ: Without Charger & Battery



Cutting Width Lebar Keratan 切割宽度	160mm (6-5/16")
Depth Adjustment Pelarasan Kedalaman 深度调整	15mm (9/16") 20mm (13/16") 25mm (1")
Strokes Per Minute (SPM) Kelajuan Strok 冲程速度	2,500
Dimensions (L x W x H) Dimensi 体积	329x177x131mm (13"x7"x5-1/8")
Net Weight Berat Bersih 淨重	1.3 - 1.5kg (2.8 - 3.3lbs)
Continuous Usage Time (approx.) Masa Penggunaan Berterusan 连续使用时间	45 min with BL1021B

* All list price shown are for reference only (exclude SST).

* Semua harga yang ditunjukkan adalah untuk rujukan sahaja (tidak termasuk SST). 所有显示的建议零售价仅供参考 (不包括SST)。

Cordless Target Kord 无绳式
LED Flashlight Lampu Suluh LED LED 照明灯
Vacuum Cleaner Pemilauhi Vakuüm 吸尘器
Drilling / Fastening Dremel / Pengikat 钻头 / 紧固件
Impact Drilling / Demolition Ganda / Pemusnah 冲击钻 / 拆除加工
Cutting Pemotong 切割
Grinding / Sanding Pengisar / Piskin 研磨 / 砂磨
Sawing Ganda 锯切
Planing / Routing Pengisar / Tampat 刨削 / 雕刻
Others Lain-lain 其他
Outdoor Power Equipment Alatan Kerja Luar 户外动力工具
Makita

12V_{max}

CXT

Li-ion Ah 4.0 2.0 1.5

US053DZ

Cordless Garden Sprayer
Penyembur Tanaman Tanpa Kord
充电式花园喷雾器



- 2-mode selectable (Mist and Stream modes)

Standard Equipment:
H-Shaped Double Head Nozzle, Spray Wand,
Spray Wand Holder, Shoulder Belt

• Z: Without Charger & Battery



VIDEO CLIP
Models and specs
may vary by country



Max Pressure Tekanan Maksimum 最大水压	0.3Mpa (3 kgf/cm ²)
Chemical Tank Tangki Kimia 化学箱容量	5L
Hose Length Panjang Hos 软管长度	1.7m
Spray Wand Length Panjang Batang Semburan 喷雾棒长度	0.5 - 0.7m
Nozzle Mounting Thread Benang Pemasangan Muncung 喷嘴安装螺纹	G 1/4
Dimensions (L x W x H) Dimensi 体积	343x182x343mm (13-1/2x7-1/8x13-1/2")
Net Weight Berat Bersih 净重	2.9 - 3.0kg (6.4 - 6.6lbs.)
Work Amount (approx.) Jumlah Kerja 工作量	60L (double outlet mist) 40L (single outlet mist) 75L (double outlet stream) 50L (single outlet stream) with BL1016

UB101DZ

Cordless Blower
Mesin Penghembus Angin
Tanpa Kord
充电式吹风机



- Zero emissions and reduced maintenance;
no need for gas or oil

Standard Equipment: Garden Nozzle (191G09-6)

• DZ: Without Charger & Battery



Max Air Volume Isipadu Angin Maksimum 最大风量	2.6m ³ /min
Max Air Velocity Velositi Angin Maksimum 最大风速	56m/s
Avg. Air Velocity Kelajuan Angin Purata 平均风速	45m/s
No Load Speed (RPM) Kelajuan Tanpa Beban 回转数	0 - 15,800
Dimensions (L x W x H) Dimensi 体积	849x155x184mm (33-1/2x6-1/8x7-1/4")
Net Weight Berat Bersih 净重	1.4 - 1.9kg (3.1 - 4.2lbs.)
Continuous Usage Time (approx.) Masa Penggunaan Berterusan 连续使用时间	Low: 45min Med: 20min High: 7min with BL1016

UB100DZ

Cordless Blower
Mesin Penghembus Angin
Tanpa Kord
充电式吹风机



- Zero emissions and reduced maintenance;
no need for gas or oil

Standard Equipment: Nozzle Assembly (123245-4)

• DZ: Without Charger & Battery



Max Air Volume Isipadu Angin Maksimum 最大风量	2.6m ³ /min
Max Air Velocity Velositi Angin Maksimum 最大风速	75m/s
Avg. Air Velocity Kelajuan Angin Purata 平均风速	62m/s
Max Sealed Suction Sedutan Terkedap 最大密封吸力	4.0kPa
No Load Speed (RPM) Kelajuan Tanpa Beban 回转数	0 - 15,800
Dimensions (L x W x H) Dimensi 体积	505x155x184mm (19-7/8x6-1/8x7-1/4")
Net Weight Berat Bersih 净重	1.4 - 1.9kg (3.1 - 4.2lbs.)
Continuous Usage Time (approx.) Masa Penggunaan Berterusan 连续使用时间	Low: 45min Med: 20min High: 8min with BL1016

MP100D
Cordless Inflator



PSI/ bar/ kPa
can be changed

Pre-set pressure
stop function

Valve Shape	Car / Motorcycle	Bicycle	Road Bike	Ball	Beach ball / Swim ring
Adapter	American	British	French	For Balls	For Swim rings/ Beach balls
Maximum Air Pressure (kPa)	250 (approx.)	300 (approx.)	700 (approx.)	100 and under	50 and under
Discharge Amount (L/ min) at Target pressure	10	9	4	11	11.5
Work Amount Battery BL1016	2 Car Tires (215/60R16)	46 Bicycle Tires (Size 26inch)	20 Road Bike Tires (700 x 23c)	63 Soccer Balls (Size 5)	54 Beach Balls (dia. 30cm)

MP100DZ

Cordless Inflator
Inflator Tanpa Kord
充电式打气机



- Inflates the Tires of Cars, Bikes, Sport Balls, etc

Standard Equipment: British Adapter,
French Adapter, Ball Adapter,
Swim Ring Adapter

• DZ: Without Charger & Battery



Max Air Pressure Udara Tekanan Maksimum 最大气压	830kPa (121 PSI) [8.3 bar]
Air Discharge Amount Pelepasan Udara 空气排放量	200kPa: 10L/min
Hose Length Panjang Hos 软管长度	65cm (25-1/2")
Dimensions (L x W x H) Dimensi 体积	235x74x173mm (9-1/4"x2-15/16"x6-13/16")
Net Weight Berat Bersih 净重	1.2 - 1.3kg (2.6 - 3.0lbs.)
Work Amount (approx.) Jumlah Kerja 工作量	2 tires with BL1016 (16" Car Tires 215/60R16)



VIDEO CLIP
MP100D
Models and specs
may vary by country

* All list price shown are for reference only (exclude SST).

* Semua harga yang ditunjukkan adalah untuk rujukan sahaja (tidak termasuk SST). 所有显示的建议零售价仅供参考 (不包括SST)。

Cordless
Target: 100% 100%

LED Flashlight
Lampu Saku LED
LED手电筒

Vacuum Cleaner
Pembersih Vakuum
吸尘器

Drilling / Fastening
Ganda / Pasak
钻孔 / 紧固

Impact Drilling / Demolition
Ganda / Pasak
冲击钻孔 / 拆除施工

Cutting
Pemotong
切割

Grinding / Sanding
Pengamiran / Pasak
研磨 / 砂磨

Sawing
Ganda
锯切

Planing / Routing
Pengamiran / Pasak
刨削 / 磨削

Others
Lain-lain
其他

Outdoor Power Equipment
Alatan Kerja Luar
园机 / 户外

Thakita
TENT

12V_{max}

CXT

Li-ion Ah 4.0 2.0 1.5

Rechargeable Green Multi Line Laser

Bright green laser for increased visibility

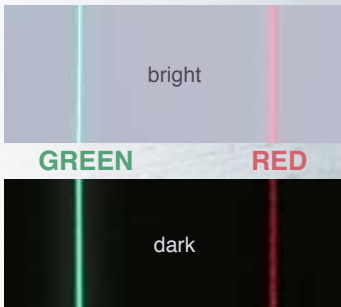

High brightness green laser for increased visibility at bright site



Horizontal / 4-Vertical lines
SK40GD

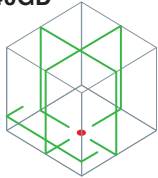

Horizontal / 2-Vertical lines
SK20GD

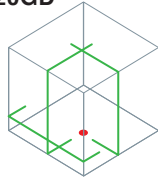

Cross line + Point
SK10GD

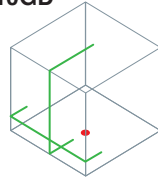

Horizontal / 2-Vertical lines
SK209GD

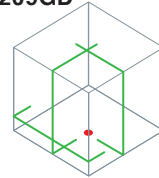

Horizontal / 3-Vertical lines
SK312GD

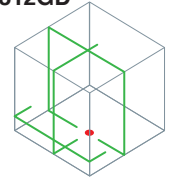

SK40GDZ | **SK20GDZ** | **SK10GDZ GREEN**

Rechargeable Green Multi Line Laser
Mesin Garis Laser Tanpa Kord
充电式激光水平仪



• High Brightness Green Laser for Increased Visibility at Bright Site

Standard Equipment:
Laser Viewing Glass,
Shoulder Strap,
Storage Case

ACCESSORIES
(Optional)
LDG-5
Laser Receiver
Part No. TK0LDG501F

• DZ : Without Charger & Battery



Leveling Accuracy Menunjukkan Ketepatan 指示精确度	±1mm / 10m
Self-leveling Range Julat Indikasi Menegak 垂直指示范围	±4°
Laser Fan Angle Sudut Kipas Laser 激光扇角	Horizontal: 110° Vertical: 130°
Laser Line Selection Pemilihan Garisan Laser 激光线选择	4V1H SK40GD 2V1H SK20GD 1V1H SK10GD
Laser Type Jenis Laser 激光类型	Laser class 2: 515nm
Protection Class Tahap Perlindungan 保护等级	IP54
Dimensions (L x W x H) Dimensi 体积	Ø98x223mm
Net Weight Berat Bersih 净重	1.4 - 1.6kg (3.1 - 3.5lbs.)
Continuous Usage Time (approx.) Masa Penggunaan Berterusan 连续使用时间	6 hrs with BL1016 SK40GD 9 hrs with BL1016 SK20GD 12 hrs with BL1016 SK10GD (max brightness mode)

SK209GDZ | **SK312GDZ GREEN**

Rechargeable Green Multi Line Laser
Mesin Garis Laser Tanpa Kord
充电式激光水平仪

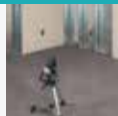

- Horizontal line - 2-Vertical line - 2-Vertical line/ horizontal line (**SK209GD**)
- Horizontal line - Horizontal/ vertical line - 3-Vertical line/ horizontal line (**SK312GD**)

Standard Equipment: Laser Viewing Glass, Shoulder Strap,
Storage Case

• DZ : Without Charger & Battery



Leveling Accuracy Menunjukkan Ketepatan 指示精确度	±1mm/ 10m
Self-leveling Range Julat Indikasi Menegak 垂直指示范围	±2°
Laser Fan Angle Sudut Perminat Laser 激光扇角	Horizontal: 110°/ Vertical: 130°
Number of Laser Lines Bilangan Garisan Laser 激光线数量	3
Laser Type Jenis Laser 激光类型	Laser class 2: 515nm
Tripod Thread Tripod 脚架	5/8"
Protection Class Tahap Perlindungan 保护等级	IP54
Dimensions (L x W x H) Dimensi 体积	BL1021B: 122x110x225mm
Net Weight Berat Bersih 净重	1.5 - 1.6kg (3.3 - 3.5lbs)
Continuous Usage Time (approx.) Masa Penggunaan Berterusan 连续使用时间	20 hrs with BL1021B SK209GD (max output) 14 hrs with BL1021B SK312GD (max output)

* All list price shown are for reference only (exclude SST).

* Semua harga yang ditunjukkan adalah untuk rujukan sahaja (tidak termasuk SST). 所有显示的建议零售价仅供参考 (不包括SST)。

Cordless
Tanpa Kord 无线式

LED Flashlight
Lampu Suluh LED
LED 照明灯

Vacuum Cleaner
Penyedut Vakuum
吸尘器

Drilling / Fastening
Dremel / Pengikat
钻头 / 螺絲

Impact Drilling / Demolition
Garu / Penembak
起工钻头 / 拆墙加工

Cutting
Pemotong
切刀

Grinding / Sanding
Pengisar / Pasir
磨刀 / 砂纸

Sawing
Gergaji
电锯

Planing / Routing
Pengisar / Tampat
刨刀 / 刨床

Others
Lain-lain
其他

Outdoor Power Equipment
Alatan Kerja Luar
园机-户外

Makita
MAKITA

12V_{max}

CXT

Li-ion Ah 4.0 2.0 1.5

Rechargeable Line Laser



Quick and easy setup

3 x full 360-degree lines

SK700D



SK700GD

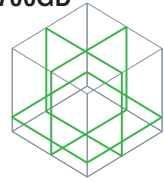

Cross line + Point

SK106D

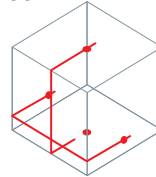

SK106GD

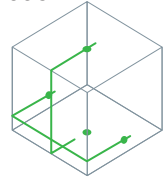

Cross line

SK105D

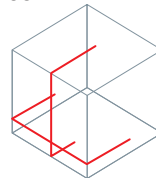

SK105GD

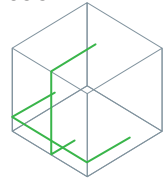

SK700D **RED** SK700GD **GREEN**

Rechargeable Multi Line Laser

Mesin Garis Laser Tanpa Kord
充电式激光水平仪



- Full 360-degree line is created by letting the laser from a light source reflect on a cone mirror

Standard Equipment:
Target Plate, Adapter, Soft Bag

- Without Charger & Battery



Leveling Accuracy Menunjukkan Ketepatan 指示精确度	2mm / 10m
Self-leveling Range Julat Indikasi Menegak 垂直指示范围	4
Laser Type Jenis Laser 激光类型	Laser class 2: 630 - 645nm SK700D Laser class 2: 510 - 530nm SK700GD
Protection Class Tahap Perlindungan 保护等级	IP54
Dimensions (L x W x H) Dimensi 体积	149x104x153mm (5-7/8x4-1/8x6")
Net Weight Berat Bersih 净重	0.99 - 1.2kg (2.2 - 2.7lbs.)
Continuous Usage Time (approx.) Masa Penggunaan Berterusan 连续使用时间	22 hrs with BL1041B SK700D 14 hrs with BL1041B SK700GD (max brightness mode)

SK106DZ **RED** SK106GDZ **GREEN**

Rechargeable Red 4-point Cross Line Laser

Mesin Garis Laser Tanpa Kord
充电式激光水平仪

- Brightness selection:
2 Modes (Bright mode/ Eco mode)

Standard Equipment: Soft Bag, Target Plate

- DZ : Without Charger & Battery



Measuring Range Jarak Mengukur 测量范围	Up to: 25m SK106D Up to: 35m SK106GD
Measuring Range w/ detector Jarak Mengukur 测量范围	Up to: 80m
Leveling Accuracy Menunjukkan Ketepatan 指示精确度	±3mm/ 10m
Self-leveling Range Julat Indikasi Menegak 垂直指示范围	±4°
Laser Fan Angle Sudut Peminat Laser 激光扇角	Horizontal: 180° Vertical: 170°
Number of Laser Bilangan Laser 激光数量	Points : 4 Lines : 2
Laser Type Jenis Laser 激光类型	Laser class 2: 635nm SK106D Laser class 2: 525nm SK106GD
Dimensions (L x W x H) Dimensi 体积	138x64x102mm (5-7/16"x2-1/2"x4")
Net Weight Berat Bersih 净重	0.69 - 0.85kg (1.5 - 1.9lbs.)
Continuous Usage Time (approx.) Masa Penggunaan Berterusan 连续使用时间	20 hrs with BL1021B SK106D (max output) 10 hrs with BL1021B SK106GD (max output)

SK105DZ **RED** SK105GDZ **GREEN**

Rechargeable Red Cross Line Laser

Mesin Garis Laser Tanpa Kord
充电式激光水平仪

- Brightness selection:
2 Modes (Bright mode/ Eco mode)

Standard Equipment: Soft Bag, Target Plate

- DZ : Without Charger & Battery



Measuring Range Jarak Mengukur 测量范围	Up to: 25m SK105D Up to: 35m SK105GD
Measuring Range w/ detector Jarak Mengukur 测量范围	Up to: 80m
Leveling Accuracy Menunjukkan Ketepatan 指示精确度	±3mm/ 10m
Self-leveling Range Julat Indikasi Menegak 垂直指示范围	±4°
Laser Fan Angle Sudut Peminat Laser 激光扇角	Horizontal: 180° Vertical: 160°
Number of Laser Lines Bilangan Garisan Laser 激光线条数量	2
Laser Type Jenis Laser 激光类型	Laser class 2: 635nm SK105D Laser class 2: 525nm SK105GD
Dimensions (L x W x H) Dimensi 体积	138x64x102mm (5-7/16"x2-1/2"x4")
Net Weight Berat Bersih 净重	0.67 - 0.84 kg (1.5 - 1.9 lbs.)
Continuous Usage Time (approx.) Masa Penggunaan Berterusan 连续使用时间	20 hrs with BL1021B SK105D (max output) 10 hrs with BL1021B SK105GD (max output)

* All list price shown are for reference only (exclude SST).

* Semua harga yang ditunjukkan adalah untuk rujukan sahaja (tidak termasuk SST). 所有显示的建议零售价仅供参考 (不包括SST)。

Cordless
Target Plate 360°

LED Flashlight
Lampu Suhu LED
LED 闪光灯

Vacuum Cleaner
Pembersih Vakuum
吸尘器

Drilling / Fastening
Gergaji / Pengikat
钻孔 / 紧固

Impact Drilling / Demolition
Gergaji / Pemusnah
冲击钻孔 / 拆墙施工

Cutting
Pemotong
切割

Grinding / Sanding
Pengkilan / Poles
打磨 / 磨光

Sawing
Gergaji
锯切

Planing / Routing
Pengkilan / Tergamit
刨平 / 雕刻

Others
Lain-lain
其他

Outdoor Power Equipment
Alatan Kuat Luar
户外动力工具



10.8V

Li-ion Ah 1.3

HP330D Cordless Hammer Driver Drill

DRILLING

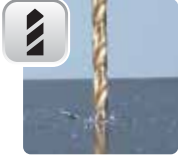

FASTENING

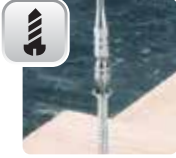

HAMMER DRILLING



HP330DWE 10mm (3/8")

Cordless Hammer Driver Drill

Tukul Pemutar Skru Bergerudi Tanpa Kord
充电式冲击螺丝起子电钻

- Hammer drill mode



10.8V



Standard Equipment: Phillips Bit, Holster

- DWE: 1x Standard Charger, 2x 1.3Ah Battery



Capacity Kapasiti 能力	Steel: 10mm (3/8") Wood: 21mm (13/16") Masonry: 8mm (5/16")
Impacts Per Minute (IPM) Impak Per Minit 冲击数	High: 0-22,500 Low: 0-6,000
No Load Speed (RPM) Kelajuan Tanpa Beban 回转数	High: 0-1,500 Low: 0-400
Max Fastening Torque Maksimum Tenaga Pemutaran Pengancing 最大紧固扭力	Hard: 24N-m Soft: 12N-m
Max Lock Torque Pemutaran Tenaga Maksimum 最大锁紧扭力	22N-m (200in.lbs.)
Dimensions (L x W x H) Dimensi 体积	201x53x183mm (7-7/8"x2-1/16"x7-1/4")
Net Weight Berat Bersih 净重	1.1kg (2.3lbs)
Work Amount (approx.) Jumlah Kerja 工作量	220 holes with BL1013 Auger Bit Drilling Ø9mm, Melapi 30mm Thickness

DF330DWE 10mm (3/8")

Cordless Driver Drill

Gerudi Pemutar Skru Tanpa Kord
充电式螺丝起子电钻

- 2-Speed design driver drill



10.8V



Standard Equipment: Phillips Bit, Holster

- DWE: 1x Standard Charger, 2x 1.3Ah Battery



Capacity Kapasiti 能力	Steel: 10mm (3/8") Wood: 21mm (13/16")
No Load Speed (RPM) Kelajuan Tanpa Beban 回转数	High: 0-1,300 Low: 0-350
Max Fastening Torque Maksimum Tenaga Pemutaran Pengancing 最大紧固扭力	Hard: 24N-m Soft: 14N-m
Max Lock Torque Pemutaran Tenaga Maksimum 最大锁紧扭力	22N-m (200in.lbs.)
Dimensions (L x W x H) Dimensi 体积	189x53x183mm (7-7/16"x2-1/16"x7-1/4")
Net Weight Berat Bersih 净重	1kg (2.2lbs)
Work Amount (approx.) Jumlah Kerja 工作量	220 holes with BL1013 Auger Bit Drilling Ø9mm, Melapi 30mm Thickness

TD090DWE

Cordless Impact Driver

Pemutar Skru Impak Tanpa Kord
充电式冲击螺丝起子机

- Compact bit sleeve 1/4" drive



10.8V



Standard Equipment: Holster

- DWE: 1x Standard Charger, 2x 1.3Ah Battery



Capacity Kapasiti 能力	Machine Screw: M4 - M8mm (5/32" - 5/16") Standard Bolt: M5 - M12 (3/16" - 1/2") High Tensile Bolt: M5 - M10 (3/16" - 3/8") Coarse thread (in length): 22 - 90mm (7/8" - 3-1/2")
No Load Speed (RPM) Kelajuan Tanpa Beban 回转数	0-2,400
Impacts Per Minute (IPM) Impak Per Minit 冲击数	0-3,000
Max Fastening Torque Maksimum Tenaga Pemutaran Pengancing 最大紧固扭力	90N-m (800in.lbs.)
Dimensions (L x W x H) Dimensi 体积	155x54x178mm (6-1/8"x2-1/8"x7")
Net Weight Berat Bersih 净重	0.92kg (2.0lbs)
Work Amount (approx.) Jumlah Kerja 工作量	550 pcs with BL1013 Bolts M8 x 16mm

TD091DWE

440

Cordless Impact Driver

Pemutar Skru Impak Tanpa Kord
充电式冲击螺丝起子机

- Battery power reduction warning lamp



10.8V



- DWE: 1x Standard Charger, 2x 1.3Ah Battery



Capacity Kapasiti 能力	Machine Screw: M4 - M8 (5/32" - 5/16") Standard Bolt: M5 - M12 (3/16" - 1/2") High Tensile Bolt: M5 - M10 (3/16" - 3/8") Coarse thread (in length): 22 - 90mm (7/8" - 3-1/2")
No Load Speed (RPM) Kelajuan Tanpa Beban 回转数	0 - 2,400
Impacts Per Minute (IPM) Impak Per Minit 冲击数	0 - 3,000
Max Fastening Torque Maksimum Tenaga Pemutaran Pengancing 最大紧固扭力	90N-m (800in.lbs.)
Dimensions (L x W x H) Dimensi 体积	134x54x200mm (5-1/4"x2-1/8"x7-7/8")
Net Weight Berat Bersih 净重	0.86kg (1.9lbs)
Work Amount (approx.) Jumlah Kerja 工作量	480 pcs with BL1013 Bolts M8x16mm

* All list price shown are for reference only (exclude SST).

* Semua harga yang ditunjukkan adalah untuk rujukan sahaja (tidak termasuk SST). 所有显示的建议零售价仅供参考 (不包括SST)。

Cordless
Tanpa Kord 无绳式

LED Flashlight
Lampu Suluh LED
LED 照明灯

Vacuum Cleaner
Pembersih Vakuum
吸尘器

Drilling / Fastening
Drauli / Pengikat
钻孔 / 紧固

Impact Drilling / Demolition
Drauli / Penanggal
起工钻孔 / 拆墙加工

Cutting
Pemotong
切割

Grinding / Sanding
Pengisar / Pasir
打磨 / 砂磨

Sawing
Gergaji
锯切

Planing / Routing
Pengalir / Tangkai
刨削 / 雕刻

Others
Lain-lain
其他

Outdoor Power Equipment
Alatan Kerja Luar
园具-户外



10.8V

Li-ion Ah 1.3

TW100DWE 9.5mm (3/8")

Cordless Impact Wrench
Perengkuh Impak Tanpa Kord
充电式冲击套筒扳手



10.8V



- 9.5mm (3/8") square drive fits most common automotive sockets

• DWE: 1x Standard Charger, 2x 1.3Ah Battery



Fastening Capacities Keupayaan Pengancing 紧固能力	Standard Bolt: M8 - M12 (5/16" - 1/2") High Tensile Bolt: M6 - M10 (1/4" - 3/8") 9.5mm (3/8")
Square Drive Batang Segi Empat 四方头	
No Load Speed (RPM) Kelajuan Tanpa Beban 回转数	0 - 2,300
Impacts Per Minute (IPM) Impak Per Minit 冲击数	0 - 3,000
Max Fastening Torque Maksimum Tenaga Pemutaran Pengancing 最大紧固扭力	110N-m (1,000in.lbs.)
Dimensions (L x W x H) Dimensi 体积	163x54x178mm (6-3/8"x2-1/8"x7")
Net Weight Berat Bersih 净重	0.95kg (2.1lbs)
Work Amount (approx.) Jumlah Kerja 工作量	550 pcs with BL1013 Bolts M8x16mm

CC300DW | CC300DZ 85mm (3-3/8")

Cordless Cutter
Pemotong Tanpa Wayar
充电式切割机



10.8V



- Adjustable cutting depth up to 25.5mm at 90° and 16.5mm at 45°

Standard Equipment: Diamond Wheel, Water Supply Tank Assembly, Hex Wrench

• DW: 1x Standard Charger, 1x 1.3Ah Battery
• DZ: Without Charger, Battery & Carrying Case



Blade Diameter Diameter Bilah 锯片直径	85mm (3-3/8")
Max Cutting Capacity Kapasiti Pemotongan Maksimum 最大切割能力	90°: 25.5mm (1") 45°: 16.5mm (5/8")
No Load Speed (RPM) Kelajuan Tanpa Beban 回转数	1,400
Tank capacity Kapasiti Tangki 水箱容量	Water : 0.5L
Dimensions (L x W x H) Dimensi 体积	300x170x154mm (11-3/4"x6-11/16"x6-1/16")
Net weight Berat Bersih 净重	16kg (3.6lbs)
Work Amount (approx.) Jumlah Kerja 工作量	2.5 pcs with BL1013 Diamond Blade (Cut Glass 10x300mm)

HS300DW 85mm (3-3/8")

Cordless Circular Saw
Gergaji Piring Tanpa Kord
充电式圆锯



10.8V



- Fast cutting of plywood, MDF, pegboard, particleboard, melamine, drywall and more

Standard Equipment: TCT Saw Blade (B-14607), Hex Wrench

• DW: 1x Standard Charger, 1x 1.3Ah Battery



Blade Diameter Diameter Bilah 锯片直径	85mm (3-3/8")
Max Cutting Capacity Kapasiti Pemotongan Maksimum 最大切割能力	90°: 25.5mm (1") 45°: 16.5mm (5/8")
No Load Speed (RPM) Kelajuan Tanpa Beban 回转数	1,400
Dimensions (L x W x H) Dimensi 体积	300x170x154mm (11-3/4"x6-11/16"x6-1/16")
Net Weight Berat Bersih 净重	1.5kg (3.4lbs)
Work Amount (approx.) Jumlah Kerja 工作量	90 cuts with BL1013 Sawing SPF 1"x4" (0 Degree Cut)

JV100DWE

Cordless Jig Saw
Gergaji Jig Tanpa Kord
充电式线锯机



10.8V



- Aluminum die-cast base adjusts from 0°-45° right to left

Standard Equipment: Jig Saw Blade (B-10), Hex Wrench, Guide Rule

• DWE: 1x Standard Charger, 2x 1.3Ah Battery



Max Cutting Capacity at 90° Kapasiti Pemotongan Maksimum 最大切割能力	Wood: 65mm (2-9/16") Aluminum: 4mm (5/32") Mild Steel: 2mm (1/16")
Length of Stroke Panjang Strok 冲程长度	18mm (11/16")
Strokes Per Minute (SPM) Kelajuan Strok 冲程速度	0 - 2,400
Dimensions (L x W x H) Dimensi 体积	231x76x196mm (9-1/8"x3"x7-3/4")
Net Weight Berat Bersih 净重	1.7kg (3.7lbs)
Work Amount (approx.) Jumlah Kerja 工作量	26 pcs with BL1013 Sawing (Fibreboard MDF 300x12mm)

JR100DWE

Cordless Recipro Saw
Gergaji Resipro Tanpa Kord
充电式往复锯



10.8V



- Dual-position on/off switch design allows for either paddle or trigger switch operation

Standard Equipment: Recipro Saw Blades 2pcs (B-20404 & B-20432)

• DWE: 1x Standard Charger, 2x 1.3Ah Battery



Capacity Kapasiti 能力	Pipe : 50mm (2") Wood : 50mm (2")
Length of Stroke Panjang Strok 冲程长度	13mm (1/2")
Strokes Per Minute (SPM) Kelajuan Strok 冲程速度	0-3,300
Dimensions (L x W x H) Dimensi 体积	355x63x146mm (14"x2-1/2"x5-3/4")
Net Weight Berat Bersih 净重	1.2kg (2.6lbs)
Work Amount (approx.) Jumlah Kerja 工作量	55 pcs with BL1013 Cutting (PVC Plastic Hose 48mm)

* All list price shown are for reference only (exclude SST).

* Semua harga yang ditunjukkan adalah untuk rujukan sahaja (tidak termasuk SST). 所有显示的建议零售价仅供参考 (不包括SST)。

Cordless
Targeted Jobs

LED Flashlight
Lampu Suhu LED
LED照明灯

Vacuum Cleaner
Pembersih Vakuum
吸尘器

Drilling / Fastening
Gantuli / Pengait
钻孔 / 紧固

Impact Drilling / Demolition
Gantuli / Penehah
冲击钻孔 / 拆除施工

Cutting
Panasir
切割

Grinding / Sanding
Pengiraan / Pencil
研磨 / 砂磨

Sawing
Gergaji
锯切

Planing / Routing
Pengiraan / Tangan
刨削 / 雕刻

Others
Lain-lain
其他

Outdoor Power Equipment
Alatan Kerja Luar
园具 / 户外

makita
1000000000

10.8V

7.2V

3.6V

JR102DWE

Cordless Recipro Saw
 Gergaji Resipro Tanpa Kord
 充电式往复锯

10.8V



- Accepts both Recipro and Jig saw blades

Standard Equipment: Hex Wrench,
Recipro Saw Blades 2pcs (B-20404 & B-20432)

- DWE: 1x Standard Charger, 2x 1.3Ah Battery



Capacity Kapasiti 能力	Pipe : 50mm (2") Wood: 50mm (2")
Length of Stroke Panjang Strok 冲程长度	13mm (1/2")
Strokes Per Minute (SPM) Kelajuan Strok 冲程速度	0-3,300
Dimensions (L x W x H) Dimensi 体积	355x63x146mm (14"x2-1/2"x5-3/4")
Net Weight Berat Bersih 淨重	1.2kg (2.6lbs)
Work Amount (approx.) Jumlah Kerja 工作量	55 pcs with BL1013 Cutting (PVC Plastic Hose 48mm)

TD022DSE

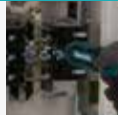
Cordless Impact Driver
 Pemutar Skru Impak Tanpa Kord
 充电式冲击螺丝起子机

7.2V



- Compact and lightweight design

Standard Equipment: Holster, Phillips Bit

- DSE: 1x Standard Charger, 2x 1.5Ah Battery



Capacity Kapasiti 能力	Machine Screw: M3 - M8 (1/8" - 5/16") Standard Bolt: M3 - M8 (1/8" - 5/16") High Tensile Bolt: M3 - M6 (1/8" - 1/4") Coarse thread (in length): 22 - 45mm (7/8" - 1-3/4")
Hex Shank Batang Heksagon 六角柄	6.35mm (1/4")
No Load Speed (RPM) Kelajuan Tanpa Beban 回转数	0 - 2,450
Impacts Per Minute (IPM) Impak Per Minit 冲击数	0 - 3,000
Max Fastening Torque Maksimum Tenaga Pemutaran Pengancing 最大紧固扭力	25N·m (220in.lbs.)
Dimensions (L x W x H) Dimensi 体积	Straight Style: 282x42x52mm (11-1/8"x1-5/8"x2-1/16") Pistol Style: 227x42x142mm (8-15/16"x1-5/8"x5-5/8")
Net Weight Berat Bersih 淨重	0.55 - 0.56kg (1.2lbs)
Work Amount (approx.) Jumlah Kerja 工作量	320 pcs with BL7010 Wood Screw ø3.1x25mm (Melapi Drove Wood)

TD020DSW

Cordless Impact Driver
 Pemutar Skru Impak Tanpa Kord
 充电式冲击螺丝起子机

7.2V



- Compact and lightweight design

Standard Equipment: Holster, Bit set

- DSW: 1x Standard Charger, 1x 1.0Ah Battery (White)



Capacity Kapasiti 能力	Machine Screw: M3 - M8 (1/8" - 5/16") Standard Bolt: M3 - M8 (1/8" - 5/16") High Tensile Bolt: M3 - M6 (1/8" - 1/4") Coarse thread (in length): 22 - 45mm (7/8" - 1-3/4")
Hex Shank Batang Heksagon 六角柄	6.35mm (1/4")
No Load Speed (RPM) Kelajuan Tanpa Beban 回转数	2,300
Impacts Per Minute (IPM) Impak Per Minit 冲击数	3,000
Max Fastening Torque Maksimum Tenaga Pemutaran Pengancing 最大紧固扭力	20N·m (177in.lbs.)
Dimensions (L x W) Dimensi 体积	Straight Style: 276x40mm (10-7/8"x1-9/16")
Dimensions (L x W x H) Dimensi 体积	Pistol Style: 213x40x131mm (8-3/8"x1-9/16"x5-1/8")
Net Weight Berat Bersih 淨重	0.53 - 0.54kg (1.2lbs)
Work Amount (approx.) Jumlah Kerja 工作量	232 pcs with BL7010 Wood screw ø3.1x25mm (Melapi White Wood)

DF012DSE

Cordless Driver Drill
 Gerudi Pemutar Skru Tanpa Kord
 充电式螺丝起子电钻

7.2V



- 2-Speed design for high or low torque applications

Standard Equipment: Phillips Bit 2pcs

- DSE: 1x Standard Charger, 2x 1.5Ah Battery



Capacity Kapasiti 能力	Steel: 5mm (3/16") Wood: 6mm (1/4")
No Load Speed (RPM) Kelajuan Tanpa Beban 回转数	High: 650 Low: 200
Max Fastening Torque Maksimum Tenaga Pemutaran Pengancing 最大紧固扭力	Hard: 5.6N·m (50in.lbs.) Soft: 3.6N·m (32in.lbs.)
Max Lock Torque Pemutaran Tenaga Maksimum 最大锁紧扭力	8.0N·m (71in.lbs.)
Dimensions (L x W x H) Dimensi 体积	Pistol Style: 218x44x142mm (8-5/8"x1-3/4"x5-5/8")
Dimensions (L x W) Dimensi 体积	Straight Style: 273x44mm (10-3/4"x1-3/4")
Net Weight Berat Bersih 淨重	0.53kg (1.2lbs.)
Work Amount (approx.) Jumlah Kerja 工作量	350 pcs with BL7010 Wood screw ø3.8x25mm (Melapi Drove Wood)

DF001DW

In-Line Cordless Screwdriver
 Pemutar Skru Tanpa Kord
 充电式螺丝起子机

3.6V



- Convenient to used even in narrow space

Standard Equipment: Bit Set 81pcs, AC Adaptor, USB Cable



Fastening Capacities Keupayaan Pengancing 紧固能力	Wood Screw: ø3.8 x 32mm (1/8"x1-1/4")
No Load Speed (RPM) Kelajuan Tanpa Beban 无负荷转速	220
Max Fastening Torque Maksimum Tenaga Pemutaran Pengancing 最大紧固扭力	Hard: 4.0N·m (35in.lbs.) Soft: 3.0N·m (27in.lbs.)
Max Lock Torque Pemutaran Tenaga Maksimum 最大锁紧扭力	6.0N·m (53 in.lbs.)
Charging Time (hours) Masa Pengecasan 充电时间	3 - 5
Dimensions (L x W x H) Dimensi 体积	Straight Style: 287x47x51mm (11-1/4"x1-7/8"x2") Pistol Style: 205x47x51mm (8-1/8"x1-7/8"x2")
Net Weight Keberatan 淨重	0.36kg (0.8 lbs.)
Work Amount (approx.) Jumlah Kerja 工作量	200 pcs Wood Screw ø3.8x25mm (SPF plate)

* All list price shown are for reference only (exclude SST).

* Semua harga yang ditunjukkan adalah untuk rujukan sahaja (tidak termasuk SST). 所有显示的建议零售价仅供参考 (不包括SST)。

Cordless
Tanpa Kord 无绳式LED Flashlight
Lampu Suluh LED
LED 照明灯Vacuum Cleaner
Pembersih Vakuum
吸尘器Drilling / Fastening
Garuhi / Pengikat
钻孔 / 紧固Impact Drilling / Demolition
Garuhi / Penembak
起子钻孔 / 拆墙加工Cutting
Pemotong
切割Grinding / Sanding
Pengisar / Piskin
打磨 / 砂磨Sawing
Gergaji
电锯Planing / Routing
Pengisar / Tangkap
刨削 / 雕刻Others
Lain-lain
其他Outdoor Power Equipment
Alatan Kerja Luar
园具-户外Makita
MAKITA

18V

14.4V

DF488DWE 13mm (1/2")**Cordless Driver Drill**Gerudi Pemutar Skru Tanpa Kord
充电式螺丝起子电钻

18V

G-Battery



- 16 clutch settings and drill mode for added fastening control



VIDEO CLIP

DF488D/HP488D

Models and specs may vary by country

Standard Equipment: (+)(-) Bit

• DWE: 1x Standard Charger, 2x 1.5Ah G-Battery



Capacity Kapasiti 能力	Steel: 13mm (1/2") Wood: 36mm (1-7/16")
Chuck Capacity Kapasiti Chuck 夹头能力	1.5 - 13mm (1/16 - 1/2")
No Load Speed (RPM) Kelajuan Tanpa Beban 回转数	High: 0 - 1,400 Low: 0 - 400
Max Fastening Torque Tenaga Pemutaran Pengancing Maksimum 最大紧固扭力	Hard: 42N·m (370 in.lbs) Soft: 24N·m (210 in.lbs)
Max Lock Torque Pemutaran Tenaga Maksimum 最大锁紧扭力	38N·m (340in.lbs.)
Clutch Torque Setting Tetapan Pemutaran 扭转设置	1 - 4N·m (9 - 35in.lbs.)
Dimensions (L x W x H) Dimensi 体积	221x83x240mm (8-3/4x3-1/4x9-1/2")
Net Weight Berat Bersih 淨重	1.7kg (3.7lbs.)

HP488DWE 13mm (1/2")**Cordless Hammer Driver Drill**Tukul Pemutar Skru Bergerudi
Tanpa Kord
充电式冲击螺丝起子电钻

18V

G-Battery



- 16 clutch settings and drill mode for added fastening control



VIDEO CLIP

DF488D/HP488D

Models and specs may vary by country

Standard Equipment: (+)(-) Bit

• DWE: 1x Standard Charger, 2x 1.5Ah G-Battery



Capacity Kapasiti 能力	Steel: 13mm (1/2") Wood: 36mm (1-7/16") Masonry: 13mm (1/2")
Chuck Capacity Kapasiti Chuck 夹头能力	1.5 - 13mm (1/16 - 1/2")
Impacts Per Minute (IPM) Impak Per Minit 冲击数	High: 0 - 21,000 Low: 0 - 6,000
No Load Speed (RPM) Kelajuan Tanpa Beban 回转数	High: 0 - 1,400 Low: 0 - 400
Max Fastening Torque Tenaga Pemutaran Pengancing Maksimum 最大紧固扭力	Hard: 42N·m (370 in.lbs) Soft: 24N·m (210 in.lbs)
Max Lock Torque Pemutaran Tenaga Maksimum 最大锁紧扭力	38N·m (340in.lbs.)
Clutch Torque Setting Tetapan Pemutaran 扭转设置	1 - 4N·m (9 - 35in.lbs.)
Dimensions (L x W x H) Dimensi 体积	239x83x240mm (9-3/8x3-1/4x9-1/2")
Net Weight Berat Bersih 淨重	1.8kg (4.0lbs.)

UM110DWAYX 110mm (4-5/16")**Cordless Grass Shear**Pemotong Rumput Tanpa Kord
充电式割草机

18V

G-Battery

2in1



- 2 in 1: Both trimmer blade and shear blade can be attached

Standard Equipment: Shear Blade, Blade Cover,
Storage Cover, Oil Vessel

• DWYX: 1x Standard Charger, 1x 1.5Ah G-Battery

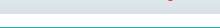

Cutting Width Lebar Keratan 切割宽度	Grass Shear Blade: 110mm (4-5/16") Hedge Trimmer Blade: 200mm (7-7/8")
Depth Adjustment Pelarasan Kedalaman 深度调整	15mm (9/16") 20mm (13/16") 25mm (1")
Strokes Per Minute (SPM) Kelajuan Strok 冲程速度	2,500
Dimensions (L x W x H) Dimensi 体积	331x120x130mm (13x4-3/4x5-1/8")
Net Weight Berat Bersih 淨重	1.4 - 1.5kg (3.1 - 3.3lbs.)
Continuous Usage Time (approx.) Masa Penggunaan Berterusan 连续使用时间	65min with BL1815G

DTL062Z 9.5mm (3/8")**Cordless Angle Impact Wrench**Perengkuh Impak Sudut
Tanpa Kord
充电式角向冲击套筒扳手

14.4V



- Compact angle head for easy access to bolts in tight places

Standard Equipment: Belt Clip

• Z: Without Charger & Battery



Fastening Capacities Keupayaan Pengancing 紧固能力	Standard Bolt: M4 - M12 (5/32" - 1/2") High Strength Bolt: M4 - M8 (5/32" - 5/16") 9.5mm (3/8")
Square Drive Skrus Persegi 方形螺柱	
No Load Speed (RPM) Kelajuan Tanpa Beban 回转数	0 - 2,000
Impacts Per Minute (IPM) Impak Per Minit 冲击数	0 - 3,000
Max Fastening Torque Tenaga Pemutaran Pengancing Maksimum 最大紧固扭力	60N·m
Dimensions (L x W x H) Dimensi 体积	387x78x97mm (15-1/4"x3-1/16"x3-13/16")
Net Weight Berat Bersih 淨重	1.4 - 1.8kg (3.0 - 4.1lbs.)

DTW152Z 12.7mm (1/2")

440

Cordless Impact WrenchPerengkuh Impak Tanpa Kord
充电式冲击套筒扳手

14.4V



- Compact and lightweight 4-pole motor

Standard Equipment: Belt Clip

• Z: Without Charger & Battery



Fastening Capacities Keupayaan Pengancing 紧固能力	Standard Bolt: M8 - M16 (5/16" - 5/8") High Strength Bolt: M8 - M12 (5/16" - 1/2") 12.7mm (1/2")
Square Drive Skrus Persegi 方形螺柱	
No Load Speed (RPM) Kelajuan Tanpa Beban 回转数	0 - 2,400
Impacts Per Minute (IPM) Impak Per Minit 冲击数	0 - 3,200
Max Fastening Torque Tenaga Pemutaran Pengancing Maksimum 最大紧固扭力	200N·m (150ft.lbs.)
Dimensions (L x W x H) Dimensi 体积	158x79x234mm (6-1/4"x3-1/8"x9-1/4")
Net Weight Berat Bersih 淨重	1.3 - 1.5kg (2.8 - 3.4lbs.)

* All list price shown are for reference only (exclude SST).

* Semua harga yang ditunjukkan adalah untuk rujukan sahaja (tidak termasuk SST). 所有显示的建议零售价仅供参考 (不包括SST).



Li-ion Ah 12 2.6 2.2

BUH550RD | BUH550Z | UH550DWB 550mm (21-5/8") 442

Cordless Hedge Trimmer

Pemangkas Tanaman Pagar Tanpa Kord
充电式篱笆树剪



36V

- 5-Position rotating rear handle for increased comfort during vertical and angle trimming

Standard Equipment: Blade Cover

- RD: 1x 36V Rapid Charger (DC36RA), 1x 36V 2.6Ah Battery (BL3626)
- DWB: 1x 36V Standard Charger (DC36WA), 1x 36V 2.2Ah Battery (BL3622A)
- Z: Without Charger & Battery



Sementara stok masih ada 售完即止
WHILE STOCK LAST
可盡速向本公司購買

Blade Length	550mm (21-5/8")
Panjang bilah 刀片长度	
Strokes Per Minute (SPM)	2,000 - 3,600
Kelajuan Strok 冲程速度	
Tooth Spacing	36mm (1-7/16")
Selang Gigi 牙齿间隔	
Dimensions (L x W x H)	1,070x220x190mm
Dimensi 体积	(42"x8-5/8"x7-1/2")
Net Weight	5.1kg (11.2lbs.)
Keberatan 净重	

BUH650RD | BUH650Z | UH650DWB 650mm (25-1/2") 442

Cordless Hedge Trimmer

Pemangkas Tanaman Pagar Tanpa Kord
充电式篱笆树剪



36V

- 5-Position rotating rear handle for increased comfort during vertical and angle trimming

Standard Equipment: Blade Cover

- RD: 1x 36V Rapid Charger (DC36RA), 1x 36V 2.6Ah Battery (BL3626)
- DWB: 1x 36V Standard Charger (DC36WA), 1x 36V 2.2Ah Battery (BL3622A)
- Z: Without Charger & Battery



Sementara stok masih ada 售完即止
WHILE STOCK LAST
可盡速向本公司購買

Blade Length	650mm (25-1/2")
Panjang bilah 刀片长度	
Strokes Per Minute (SPM)	2,000 - 3,600
Kelajuan Strok 冲程速度	
Tooth Spacing	36mm (1-7/16")
Selang Gigi 牙齿间隔	
Dimensions (L x W x H)	1,150x220x190mm
Dimensi 体积	(45-1/4"x8-5/8"x7-1/2")
Net Weight	5.2kg (11.5lbs.)
Keberatan 净重	

BUN490RD

Cordless Pole Hedge Trimmer

Pemangkas Tanaman Pagar Tinggi Tanpa Kord
充电式高枝篱笆树剪



36V

- Can be folded in the 180° position for easy transport and storage

Standard Equipment: Band Assembly, Wrench, Accessory Bag

- RD: 1x 36V Rapid Charger (DC36RA), 1x 36V 2.6Ah Battery (BL3626)



Sementara stok masih ada 售完即止
WHILE STOCK LAST
可盡速向本公司購買

Strokes Per Minute (SPM)	High: 0 - 4,000 Low: 0 - 2,800
Kelajuan Strok 冲程速度	
Tooth Spacing	35mm (1-3/8")
Selang Gigi 牙齿间隔	
Dimensions (L x W x H)	2,595x226x211mm
Dimensi 体积	(100-3/16"x8-7/8"x8-5/16")
Net Weight	6.9kg (15.2 - 15.3lbs.)
Keberatan 净重	

BBC231UZ

Cordless Brushcutter

Pemotong Rumput Tanpa Kord
充电式割草机



36V

- Low noise level and zero emissions for operator comfort

Standard Equipment: Blade, Guard, Shoulder Harness with Double Shoulder Strap, Wrenches

- UZ: Without Charger & Battery



Sementara stok masih ada 售完即止
WHILE STOCK LAST
可盡速向本公司購買

No Load Speed (RPM)	High: 0-7,300 Low: 0-5,300
Kelajuan Tanpa Beban 回转数	
Spindle Size	M10 x 1.25LH
Saiz Spindel 主轴尺寸	
Dimensions (L x W x H)	1,880x620x490mm
Dimensi 体积	(74"x24-3/8"x19-1/4")
Net Weight	7.1kg (15.7lbs.)
Keberatan 净重	
Continuous Usage Time (approx.)	Low: 30 min with BL3626
Masa Penggunaan Berterusan 连续使用时间	Metal blade with load

BML360 (STEXBML360)

Cordless Fluorescent Light

Lampu Suluh Tanpa Kord
充电式工作灯



36V

- Wide and bright illumination

- Without Charger & Battery

Sementara stok masih ada 售完即止
WHILE STOCK LAST
可盡速向本公司購買



Dimensions (L x W x H)	283x128x203mm
Dimensi 体积	(11-1/8"x5"x8")
Net Weight	2.3kg (5.1lbs.)
Berat Bersih 淨重	

* All list price shown are for reference only (exclude SST).

* Semua harga yang ditunjukkan adalah untuk rujukan sahaja (tidak termasuk SST). 所有显示的建议零售价仅供参考 (不包括SST)。

Cordless Target Kord 无绳式
LED Flashlight Lampu Suluh LED LED 闪光灯
Vacuum Cleaner Pembersih Vakuim 吸尘器
Drilling / Fastening Daurul / Pengikat 钻式 / 螺絲
Impact Drilling / Demolition Daurul / Penyahoh 钻式钻式 / 拆屋加工
Cutting Pemotong 切割
Grinding / Sanding Pengisar / Piskin 磨粉 / 磨砂
Sawing Gergaji 锯切
Planing / Routing Pengisar / Tangkapan 磨粉 / 磨粉
Others Lain-lain 其他
Outdoor Power Equipment Alatan Kerja Luar 园林-户外
Makita

Cordless
Terdapat Model 3000+

LED Flashlight
Lampu Suluh LED
LEDWORKS

Vacuum Cleaner
Pembersih Vakuum
VACUUM

Drilling / Fastening
Gantrel / Pengikat
DRILL / DRIVER

Impact Drilling / Demolition
Gantrel / Perusak
DRILL / DEMOLITION

Cutting
Pemotong
CUTTER

Grinding / Sanding
Pengam / Pemoles
GRINDER / SANDER

Sawing
Gergaji
SAW

Planing / Routing
Pergesekan / Tumpang
PLANER / ROUTER

Others
Lain-lain
OTHERS

Outdoor Power Equipment
Alat-alat Listrik
OUTDOOR POWER EQUIPMENT

Makita
19155

Cordless Cooler and Warmer Box

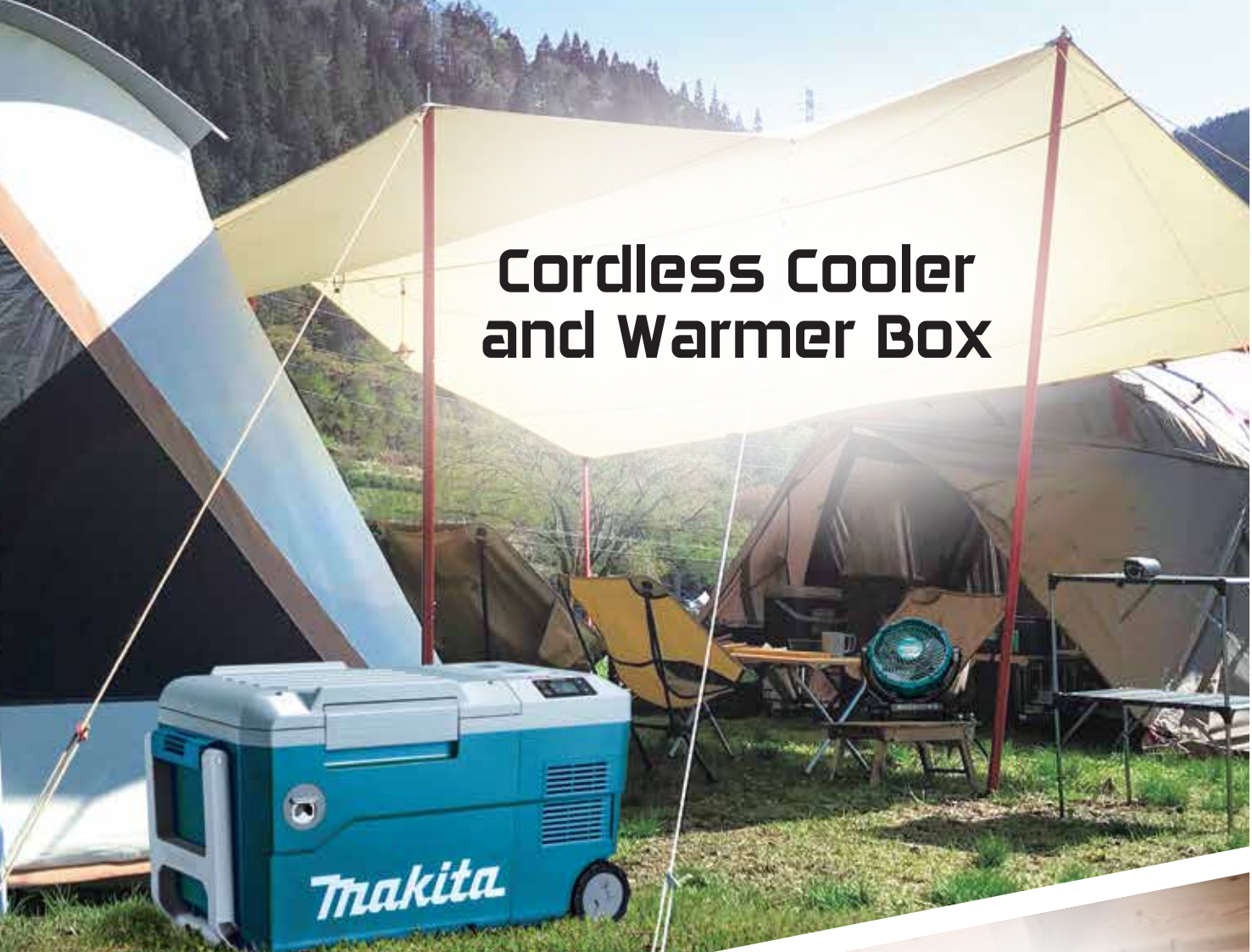

Cordless Fan



Cordless Kettle





MR006GZ 40Vmax / 18V / 12Vmax / AC

Job Site Radio
Radio Tanpa Kord
充电式收音机

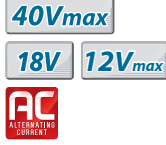

- The woofer on the bottom & the midrange/treble speakers on both sides provide deeper & richer high quality sound to suit various music genres

Standard Equipment: AC Adaptor, AA Battery

- GZ: Without Charger & Battery



Frequency Band Julat Kekelaparan 频率范围	FM: 87.5 - 108 MHz AM: 522 - 1,710 kHz
Speaker Size Saiz Speaker 扬声器尺寸	Sides: Dia. 63.5 mm x2 Bottom: Dia. 101.6 mm
Bluetooth Bluetooth 蓝牙连接	Version: 5.0 Supported Code: SBC Profile: A2DP / SCMS-T / AVRCP Max Transmission Range (Optimum): 10m (33ft) Max Transmission Range (Possible): 30m (98ft) Transmission Power Class: 2 Compatible Bluetooth Profile: A2DP
Dimensions (L x W x H) Dimensi 体积	285 x 172 x 305 mm (11-1/4 x 6-3/4 x 12")
Net Weight Berat Bersih 淨重	5.6 - 6.4 kg (12.3 - 14.1 lbs.)
Continuous Usage Time (approx.) Masa Penggunaan Berterusan 连续使用时间	19 hrs with BL4040

DMR300 18V / 12Vmax / AC

Job Site Charger Radio
Radio Tanpa Kord
充电式收音机



- Clear sound quality can be enjoyed even during battery charging

Standard Equipment: AC Adaptor, AA Battery

- Without Charger & Battery



Frequency Band Julat Kekelaparan 频率范围	FM: 87.5 - 108MHz AM: 522 - 1,710kHz
Speaker Size Saiz Speaker 扬声器尺寸	Sides: Ø63.5mm x2 Bottom: Ø101.6mm
Bluetooth Bluetooth 蓝牙连接	Version: 5.0 Profile: A2DP SCMS-T Supported Codec: SBC Max Transmission Range (Optimum): 10m (33ft) Max Transmission Range (Possible): 30m (98ft) Transmission Power Class: 2
Dimensions (L x W x H) Dimensi 体积	268x185x427mm (10-1/2x7-1/4x16-3/4")
Net Weight Berat Bersih 淨重	6.1 - 6.6kg (13.5 - 14.6lbs.)
Continuous Usage Time (approx.) Masa Penggunaan Berterusan 连续使用时间	24.7 hrs with BL1860B

DMR114 18V / 12Vmax / AC

Job Site Radio
Radio Tanpa Kord
充电式收音机



- Equipped with equalizer for 7 selectable sound modes

Standard Equipment: AC Adaptor

- Without Charger & Battery



Frequency Band Julat Kekelaparan 频率范围	FM: 87.5 - 108MHz AM: 522 - 1,710kHz
Speaker Size Saiz Speaker 喇叭尺寸	Sides: Ø63.5mm x2 Bottom: Ø101.6mm
Bluetooth Bluetooth 蓝牙连接	Version: 5.0 Profile: A2DP SCMS-T AVRCP Supported Codec: SBC / AAC Max Transmission Range: (Optimum): 10m (33ft) (Possible): 30m (98ft) Transmission Power Class: 2 Compatible Bluetooth Profile: A2DP
Dimensions (L x W x H) Dimensi 体积	268x164x295mm (10-1/2"x6-6/8"x11-5/8")
Net Weight Berat Bersih 淨重	5.1 - 5.6kg (11.3 - 12.3lbs.)
Continuous Usage Time (approx.) Masa Penggunaan Berterusan 连续使用时间	17 hrs with BL1850B

DMR203 18V / 12Vmax / AC

Cordless Job Site Speaker
Pembesaran Suara Tanpa Kord
充电式音箱



- Equipped with equalizer for 7 selectable sound modes

Standard Equipment: AC Adaptor

- Without Charger & Battery



Speaker Size Saiz Speaker 喇叭尺寸	Woofer: Ø101.6mm Tweeter: Ø36mm Passive Radiator: Ø89mm
Bluetooth Bluetooth 蓝牙连接	Version: 5.0 Profile: A2DP SCMS-T AVRCP Supported Codec: SBC Max Transmission Range: 10m (33ft) Max Transmission Range (Possible): 30m (100ft)
Dimensions (L x W x H) Dimensi 体积	217x206x199mm (8-1/2"x8-1/8"x7-7/8")
Net Weight Berat Bersih 淨重	2.7 - 3.4kg (6.0 - 7.5lbs.)
Continuous Usage Time (approx.) Masa Penggunaan Berterusan 连续使用时间	29 hrs with BL1850B (AUX-IN)

Product Comparison List

Run Time (hrs)	Up to: 19 with BL4040	MR006G	Up to: 24.7 with BL1860B	DMR300	Up to: 17 with BL1850B	DMR114	Up to: 26 Bluetooth with BL1850B	DMR203
Speaker Size	Sides: Ø63.5mm x2 Bottom: Ø101.6mm		Ø89mm x2		Sides: Ø63.5mm x2 Bottom: Ø101.6mm		Woofer: Ø101.6mm Tweeter: Ø36mm Passive Radiator: Ø89mm	
Bluetooth	●	●	●	●	●	●	●	●
Net Weight	5.6 - 6.4kg (12.3 - 14.1lbs.)		6.1 - 6.6kg (13.5 - 14.6lbs.)		5.1 - 5.6kg (11.3 - 12.3lbs.)		2.7 - 3.4kg (6.0 - 7.5lbs.)	

* All list price shown are for reference only (exclude SST).

* Semua harga yang ditunjukkan adalah untuk rujukan sahaja (tidak termasuk SST). 所有显示的建议零售价仅供参考 (不包括SST)。

18V

LXT

12V_{max}

CXT

DCF203Z 18V**Cordless Fan**
Kipas Tanpa Kord
充电式风扇

18V



- Cordless automatic swing fan

- Z : Without Charger & Battery

**Max Air Velocity**

Kelajuan Angin Maksimum 最大风速

High: 190m/min | Med: 150m/min | Low: 120m/min

Air Flow

Aliran Udara 空气流量

High: 8.2m³/min | Med: 6.5m³/min | Low: 5.2m³/min**Dimensions (L x W x H)**

Dimensi 体积

140x333x447mm

(5-1/2"x13"x16-1/2")

Net Weight

Berat Bersih 净重

1.9 - 2.6kg (4.2 - 5.6lbs.)

Continuous Usage Time (approx.)

Masa Penggunaan Berterusan 连续使用时间

Low: 1,010 min | Med: 650 min | High: 410 min with BL1860B



DCF203

VIDEO CLIP

Models and specs may vary by country.

DCF102Z 18V**Cordless Fan**
Kipas Tanpa Kord
充电式风扇

18V



- Automatically Swings 45° L/R

- Z : Without Charger & Battery

**Air Flow**

Aliran Udara 空气流量

High: 4.6L/min | Med: 3.8L/min | Low: 3.0L/min

Dimensions (L x W x H)

Dimensi 体积

185x272x284mm

(7-1/4"x10-3/10"x11-1/8")

Net Weight

Berat Bersih 净重

1.3 - 2.0kg (2.9 - 4.4lbs.)

Continuous Usage Time (approx.)

Masa Penggunaan Berterusan 连续使用时间

Low: 1,270 min | Mid: 705 min | High: 575 min with BL1860B

CF101DZ 12V_{max}**Cordless Fan**
Kipas Tanpa Kord
充电式风扇12V_{max}

- Automatically Swings 45° L/R

- Z : Without Charger & Battery

**Air Flow**

Aliran Udara 空气流量

High: 4.6L/min | Med: 3.8L/min | Low: 3.0L/min

Dimensions (L x W x H)

Dimensi 体积

185x260x284mm

(7-1/4"x10-1/4"x11-1/8")

Net Weight

Berat Bersih 净重

1.3 - 1.7kg (2.8 - 3.8lbs.)

Continuous Usage Time (approx.)

Masa Penggunaan Berterusan 连续使用时间

Low - 315min | Med - 190min | High - 135min with BL1021B

DCF201Z 18V**Cordless Fan**
Kipas Tanpa Kord
充电式风扇

18V



- Strong enough to create a comfortable work environment under hot weather

- Z : Without Charger & Battery

**Dimensions (L x W x H)**

Dimensi 体积

263x330x523mm

(10-3/8"x13"x20-5/8")

Net Weight

Berat Bersih 净重

2.5 - 2.9kg (5.5 - 6.3lbs.)

Continuous Usage Time (approx.)

Masa Penggunaan Berterusan 连续使用时间

Low: 330min | High: 165min with BL1850B

CF100DZ 12V_{max} / AC**Cordless Fan**
Kipas Tanpa Kord
充电式风扇12V_{max}

- Compact Size Allows Installation Even in Small Spaces

Standard Equipment: AC Adaptor

- Z : Without Charger & Battery

**Dimensions (L x W x H)**

Dimensi 体积

148x260x252mm

(5-7/8"x10-1/4"x9-7/8")

Net Weight

Berat Bersih 净重

1.2 - 1.4kg (2.7 - 3.1lbs)

Continuous Usage Time (approx.)

Masa Penggunaan Berterusan 连续使用时间

Low - 315min | Med - 190min | High - 135min with BL1021B

Cordless
Tangkas Tanpa KordLED Flashlight
Lampu Saku LED
LED筒射灯Vacuum Cleaner
Pembersih Vakuum
吸尘器Drilling / Fastening
Ganjal / Pengikat
钻孔 / 紧固Impact Drilling / Demolition
Ganjal / Patahkan
钻孔 / 砸毁Cutting / Finishing
Pangkas / Finishing
切割 / 打磨Grinding / Sanding
Pengkilan / Poles
研磨 / 砂磨Sawing
Gergaji
锯切Planing / Routering
Pengkilan / Tangan
刨平 / 雕刻Others
Lain-lain
其他Outdoor Power Equipment
Alatan Kuasa Luar
园具 / 户外Makita
MAKITA

* All list price shown are for reference only (exclude SST).

* Semua harga yang ditunjukkan adalah untuk rujukan sahaja (tidak termasuk SST). 所有显示的建议零售价仅供参考 (不包括SST)。

40V Li-ION
max

XGT

18V

LXT

12V max

CXT

Product Comparison List

	DCF203 18V	DCF102 18V	CF101D 12Vmax	DCF201 18V	CF100D 12Vmax
Run time (min.)	High: 360 Med: 580 Low: 960 with BL1850B	High: 480 Med: 585 Low: 1060 with BL1850B	High: 275 Med: 380 Low: 630 with BL1041B	High: 180 Low: 400 with BL1850B	High: 275 Med: 380 Low: 630 with BL1041B
Max air speed (m/min)	190	180	180	120	180
Fan size (mm)	235	180	180	250	180
Automatic swing fan	●	●	●		
Net weight	1.9 - 2.6 kg (4.2 - 5.6 lbs.)	1.3 - 2.0 kg (2.9 - 4.4 lbs.)	1.3 - 1.7 kg (2.8 - 3.8 lbs.)	2.5 - 2.9 kg (5.5 - 6.3 lbs.)	1.2 - 1.4 kg (2.7 - 3.1 lbs.)

CW001G Cordless Cooler and Warmer Box

40V Li-ION
max

18V
LITHIUM-ION

Large
Capacity

20L

Bottle Opener

More detailed inside temperature settings

	Cool storage						Hot storage							
°C	-18	-15	-10	-5	0	5	10	30	35	40	45	50	55	60
°F	0	5	15	25	30	40	50	85	95	105	115	120	130	140

CW001GZ 40Vmax / 18V

Cordless Cooler & Warmer Box

Kotak Penyejuk dan Panas
Tanpa Kord
充电式保冷箱

- Compressor type cooling system provides excellent cooling capacity

Standard Equipment:
Shoulder Belt, Cigar Socket Cable

- GZ: Without Charger & Battery

XGT



40Vmax **18V**



Capacity 20L (5.3 gal)

Kapasiti 容量

Cooling Capacity -18 / -15 / -10 / -5 / 0 / 5 / 10°C

Kapasiti Penyejukan 冷却能力 (0 / 5 / 15 / 25 / 30 / 40 / 50°F)

Warming Capacity 30 / 35 / 40 / 45 / 50 / 55 / 60°C

Kapasiti Pemanasan 加热能力 (85 / 95 / 105 / 115 / 120 / 130 / 140°F)

Cord Length 2m (6.5ft)

Panjang Kord 电源线长度 Cigar Socket Cable: 2.5m (8.2ft)

Thermal Insulation Thickness 33mm

Ketebalan Penebat Terma 保温厚度

Dimensions (L x W x H) 663x341x372mm

Dimensi 体积 (26-1/8x13-3/8x14-5/8")

Net Weight 13.8 - 16.1kg (30.4 - 35.5lbs.)

Berat Bersih 净重

Continuous Usage Time (approx.) 10 hrs with BL4050F x2
Masa Penggunaan Berterusan 连续使用时间

8.5 hrs with BL4050F x2
in warming at 60°C

* All list price shown are for reference only (exclude SST).

* Semua harga yang ditunjukkan adalah untuk rujukan sahaja (tidak termasuk SST). 所有显示的建议零售价仅供参考 (不包括SST)。



DKT360 Cordless Kettle



Hot Water, Anytime Anywhere

Easy to read water scale

Kettle can be turned on only when grounded

Dual battery fuel gauges

• Auto shut-off after boiling
• Boil-dry protection

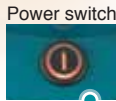
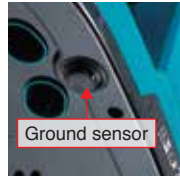

Water tank capacity	Boiling time (23°C) (approx.)	Battery BL1850B x2 capacity of boiling water (23°C) (approx.)
0.8 L	8 min	1.4 L

Easy to carry around
Kettle can be transferred easily on Power supply stand by holding the carrying handle of the stand



Removable
Removable for easy water supply and cleaning



Dual layer structure
Stainless steel interior plus plastic exterior* provides high heat retention while keeping Kettle surface cool



Anti-spill lock button
Provided to minimize spilling of hot water even if Kettle falls over



DKT360Z 18Vx2

Cordless Kettle
Cerek Tanpa Kord
充电式热水壶



• Water can be boiled without fire even at job sites where AC socket is not available



* Z: Without Charger & Battery

Water Tank Capacity Kapasiti Tangki Air 水箱容量	800mL
Dimensions (L x W x H) Dimensi 体积	233x263x307mm (9-1/8x10-3/8x12-1/8")
Net Weight Berat Bersih 淨重	2.7 - 3.4kg (6.0 - 7.5lbs.)
Work Amount (approx.) Jumlah Kerja 工作量	1.7 L boiled water with BL1860B x2 Starting water temperature 23°C

ADP001G (TWAADP001G) 40Vmax

Adapter for USB
Penyesuai untuk USB
USB适配器



• Two USB output ports; equipped with two Type A USB ports for DC5V/ 2.4A output from each port



* Without Charger & Battery

USB Port Soket USB 插口位置	2 (Type A)
Dimensions (L x W x H) Dimensi 体积	119x79x88mm (4-11/16x3-1/8x3-1/2")
Net Weight Berat Bersih 淨重	0.8 - 1.4kg (1.8 - 3.1lbs.)
Work Amount (approx.) Jumlah Kerja 工作量	7 times with BL4050F Charging iPhone XR

* All list price shown are for reference only (exclude SST).

* Semua harga yang ditunjukkan adalah untuk rujukan sahaja (tidak termasuk SST). 所有显示的建议零售价仅供参考 (不包括SST)。

Cordless
Tangki Tanpa Kord

LED Flashlight
Lampu Suluh LED
LED 闪光灯

Vacuum Cleaner
Pembersih Vakuum
吸尘器

Drilling / Fastening
Ganda / Pengikat
钻孔 / 紧固

Impact Drilling / Demolition
Ganda / Penebuk
冲击钻孔 / 拆毁施工

Cutting
Pemotong
切割

Grinding / Sanding
Pengkilan / Pemoles
研磨 / 砂磨

Sawing
Gergaji
锯切

Planing / Routing
Pegayaan / Tonggaman
刨削 / 雕刻

Others
Lain-lain
其他

Outdoor Power Equipment
Alatan Kerja Luar
园机 / 户外





ADP05 (AUBADP05) 18V

Adapter for USB
Penyesuai untuk USB
USB适配器



18V



• As a charger for smart phones

• Without Charger & Battery

USB Port Soket USB 插口位置	2 (Type A)
Dimensions (L x W x H) Dimensi 体积	102x72x43mm (4"x2-13/16"x1-11/16")
Net Weight Berat Bersih 淨重	0.46 - 0.71kg (1.0 - 1.6lbs)
Work Amount (approx.) Jumlah Kerja 工作量	10 times with BL1850B Charging Iphone 6S (1715 mA-h)

ADP06 (AUAADP06) | ADP08 (AUAADP08) 12Vmax

Adapter for USB
Penyesuai untuk USB
USB适配器



12Vmax

ADP06



ADP08



• As a charger for smart phones

• Without Charger & Battery

Battery Bateri 電池	12Vmax 1.5Ah, 2.0Ah, 4.0Ah
USB Port Soket USB 插口位置	1 (Type A)
Devices Peralatan 设备	iOS & Android
Dimensions (L x W x H) Dimensi 体积	80x53x38mm ADP06 (3-1/8"x2-1/16"x1-1/2") 80x53x28mm ADP08 (3-1/8"x2-1/16"x1-1/8")
Net Weight Berat Bersih 淨重	0.27 - 0.44kg (0.6 - 1.0lbs)
Work Amount (approx.) Jumlah Kerja 工作量	1 time charges with BL1021B ADP06 Charging Iphone 7 (1960 mA-h) 1 time charges with BL1021B ADP08 Charging Iphone 7 (1960 mA-h)

DCM501 *18V LITHIUM-ION* *12Vmax LITHIUM-ION*
Cordless Coffee Maker

Capacity of Cup



• Carry Handle for easy transport

Water Tank Capacity
240mL

Makita genuine cafe pods are prepared 20pcs/box

• Cover is slide left and right to protect the empty port when a battery is inserted

Brazil
Fragrant bitter & deep flavor

Mocha
Sweet scent & mild taste

Kilimanjaro
Aftertaste with bitter sweet & sharpness

DCM501Z 18V / 12Vmax

Cordless Coffee Maker
Mesin Kopi Tanpa Kord
充电式咖啡机



18V

12Vmax



• Large tank capacity of 240 mL

Standard Equipment: Mug, Measuring Spoon

• Z : Without Charger & Battery

Water Tank Capacity Kapasiti Tangki Air 水箱容量	240mL
Compatible Cafe Pod Type Kapasiti Kopi 咖啡容量	60mm
Dimensions (L x W x H) Dimensi 体积	243x187x218mm (9-9/16"x7-3/8"x8-9/16")
Net Weight Berat Bersih 淨重	1.9 - 2.2kg (4.1 - 4.8lbs.)
Continuous Usage Time (approx.) Masa Penggunaan Berterusan 连续使用时间	4cups 160mL Coffee with BL1860B



DCM501

VIDEO CLIP
Models and specs may vary by country

* All list price shown are for reference only (exclude SST).

* Semua harga yang ditunjukkan adalah untuk rujukan sahaja (tidak termasuk SST). 所有显示的建议零售价仅供参考 (不包括SST)。

Cordless Target Kord 无线式
LED Flashlight Lampu Suluh LED LED 手电筒
Vacuum Cleaner Pemilauhi VAKUUM 吸尘器
Drilling / Fastening Daurul / Pengikat 钻式 / 螺丝
Impact Drilling / Demolition Daurul / Penembak 钻式 / 拆墙工具
Cutting Pemotong 切割
Grinding / Sanding Pengisar / Pasukan 磨削 / 砂磨
Sawing Gergaji 锯切
Planing / Routing Pengisar / Tangkapan 刨削 / 雕刻
Others Lain-lain 其他
Outdoor Power Equipment Alatan Kerja Luar 户外电源设备



18V

LXT

12Vmax

CXT

Li-ion Ah 6.0 5.0 4.0 3.0 2.0 1.5

Cordless Fan Jacket



Max Air Flow
2.2m³/min
 (Turbo Mode)

Model No.	Battery Holder
DFJ211 DFJ216 DFJ300 DFJ416 DFJ311 DFV214A DFJ400 DFV210 DFJ411 FJ502D DFJ212 FJ203D DFJ213 FJ301D DFJ214 FJ401D	 Battery Holder Set Part No. 198732-2
DCV202 DCB200	 Battery Holder Set Part No. YL00000004
DCV202 CB100D	 Battery Holder Set Part No. YL00000003
DFV214A	 Battery Holder Set Part No. TD00000111

Jacket Size



Fan Vest

	size (in cm)	S	M	L	XL	2XL	3XL
DFV210 DFV214A	Length	67	69	71	72	73	74
	Shoulder	43	45	47	49	51	53
	Chest	113	118	123	128	133	138
	Waist	107	112	117	122	127	132

Heated Vest

	size (in cm)	S	M	L	XL	2XL	3XL
DCV202	Length	72	73	74	75	76	77
	Shoulder	47.5	49.5	51.5	53.5	55.5	57.5
	Chest	114	120	126	132	138	144
	Waist	116	122	128	134	140	146

Fan Jacket

	size (in cm)	S	M	L	XL	2XL	3XL
DFJ212	Length	66	68	70	71	72	73
	Shoulder	44	46	48	50	52	54
	Sleeve*	87	90	93	95	97	99
	Chest	117	122	127	132	137	142
DFJ213	Length	65	67	69	70	71	72
	Shoulder	47	49	51	53	55	57
	Sleeve	62	64	66	67	68	69
	Chest	117	122	127	132	137	142
DFJ214 DFJ214O	Length	68	70	72	73	74	75
	Shoulder	47	49	51	53	55	57
	Sleeve	62	64	66	67	68	69
	Chest	117	122	127	132	137	142
DFJ216	Length	67	69	71	72	73	74
	Shoulder	47	49	51	53	55	57
	Sleeve	62	64	66	67	68	69
	Chest	119	124	129	134	139	144
DFJ416	Length	89 ~ 113	94 ~ 118	99 ~ 123	104 ~ 128	109 ~ 133	114 ~ 138
	Shoulder	65	67	69	70	71	72
	Sleeve	47	49	51	53	55	57
	Chest	62	64	66	67	68	69
DFJ211 DFJ311 DFJ411	Length	119	124	129	134	139	144
	Shoulder	103 ~ 111	108 ~ 116	113 ~ 121	118 ~ 126	123 ~ 131	128 ~ 136
	Sleeve	65	67	69	70	71	72
	Chest	47	49	51	53	55	57
DFJ211 DFJ311 DFJ411	Length	68	70	72	74	76	78
	Shoulder	56.5	59	61.5	64	66.5	69
	Sleeve	58	60	62	64	66	68
	Chest	126	131	136	141	146	151
DFJ211 DFJ311 DFJ411	Waist	87 ~ 113	92 ~ 113	97 ~ 113	102 ~ 133	107 ~ 138	112 ~ 143

* All list price shown are for reference only (exclude SST).

* Semua harga yang ditunjukkan adalah untuk rujukan sahaja (tidak termasuk SST). 所有显示的建议零售价仅供参考 (不包括SST)。

Cordless
Targeted Jobs

LED Flashlight
Lampu Saku LED
LED 手电筒

Vacuum Cleaner
Pembersih Vakuum
吸尘器

Drilling / Fastening
Gantut / Pengikat
钻孔 / 紧固

Impact Drilling / Demolition
Gantut / Pengikat
冲击钻孔 / 拆除施工

Cutting / Finishing
Pemotong / Finishing
切割 / 打磨

Grinding / Sanding
Pengkilan / Pemoles
打磨 / 抛光

Sawing / Cutting
Gergaji
锯切

Planing / Routing
Pengkilan / Tumpang
刨削 / 榫槽

Others
Lain-lain
其他

Outdoor Power Equipment
Alatan Keras Luar
户外动力设备

Makita
MAKITA



Cordless
Tanpa Kord / 无线式

LED Flashlight
Lampu Suling LED
LED 照明灯

Vacuum Cleaner
Pembersih Vakuum
吸尘器

Drilling / Fastening
Drobul / Pengikat
钻 / 紧固

Impact Drilling / Demolition
Drobul / Penembak
冲击钻 / 拆除加工

Cutting
Pemotong
切割

Grinding / Sanding
Pengisar / Piskin
打磨 / 砂磨

Sawing
Gergaji
锯切

Planing / Routing
Pengisar / Tangkai
刨 / 雕刻

Others
Lain-lain
其他

Outdoor Power Equipment
Alatan Kerja Luar
园机-户外



DFJ216ZL 18V / 12Vmax

Cordless Fan Jacket
Jaket Kipas Tanpa Kord
充电式风扇夹克



- Equipped with Two Flat Fan Units with BL Motor for Increased Comfort

• Without Charger & Battery



Air Flow Settings Tetapan Aliran Udara 空气流量设置	Turbo High Medium Low
Air Flow Aliran Udara 空气流量	Turbo: 2.2m³/min High: 2.1m³/min Med: 1.7m³/min Low: 1.5m³/min
Size Saiz 尺寸	L
Pockets Poket 口袋	5
Net Weight Berat Bersih 淨重	0.23kg (N/A lbs.)
Continuous Usage Time (approx.) Masa Penggunaan Berterusan 连续使用时间	Low: 27.5 hrs Medium : 20 hrs High: 11 hrs with BL1850B

Polyester

- High repellency fabric

DFJ416ZL 18V / 12Vmax

Cordless Fan Jacket
Jaket Kipas Tanpa Kord
充电式风扇夹克



- Equipped with Two Flat Fan Units with BL Motor for Increased Comfort

• Without Charger & Battery



Air Flow Settings Tetapan Aliran Udara 空气流量设置	Turbo High Medium Low
Air Flow Aliran Udara 空气流量	Turbo: 2.2m³/min High: 2.1m³/min Med: 1.7m³/min Low: 1.5m³/min
Size Saiz 尺寸	L
Pockets Poket 口袋	5
Net Weight Berat Bersih 淨重	0.23kg (N/A lbs.)
Continuous Usage Time (approx.) Masa Penggunaan Berterusan 连续使用时间	Low: 27.5 hrs Medium : 20 hrs High: 11 hrs with BL1850B

Polyester + Titanium coating

- Reflects infrared rays and ultraviolet rays

DFJ211ZM | DFJ211ZL | DFJ211ZXL 18V / 12Vmax

Cordless Fan Jacket
Jaket Kipas Tanpa Kord
充电式风扇外套



- Equipped with Two Flat Fan Units with BL Motor for Increased Comfort

• Without Charger & Battery



Air Flow Settings Tetapan Aliran Udara 空气流量设置	Turbo High Medium Low
Air Flow Aliran Udara 空气流量	Turbo: 2.2m³/min High: 2.1m³/min Med: 1.7m³/min Low: 1.5m³/min
Size Saiz 尺寸	M L XL
Pockets Poket 口袋	5
Net Weight Berat Bersih 淨重	0.41kg (0.9lbs.)
Continuous Usage Time (approx.) Masa Penggunaan Berterusan 连续使用时间	Low: 29 hrs Medium: 21 hrs High: 12 hrs with BL1850B

Polyester For general work
Untuk kerja am | 用于一般工作

- Superior moisture permeability and water repellent

DFJ311ZM | DFJ311ZL | DFJ311ZXL 18V / 12Vmax

Cordless Fan Jacket
Jaket Kipas Tanpa Kord
充电式风扇外套



- Equipped with Two Flat Fan Units with BL Motor for Increased Comfort

• Without Charger & Battery



Air Flow Settings Tetapan Aliran Udara 空气流量设置	Turbo High Medium Low
Air Flow Aliran Udara 空气流量	Turbo: 2.2m³/min High: 2.1m³/min Med: 1.7m³/min Low: 1.5m³/min
Size Saiz 尺寸	M L XL
Pockets Poket 口袋	5
Net Weight Berat Bersih 淨重	0.52kg (1.1lbs.)
Continuous Usage Time (approx.) Masa Penggunaan Berterusan 连续使用时间	Low: 29 hrs Medium: 21 hrs High: 12 hrs with BL1850B

Cotton For welding/ grinding work
Untuk kerja kimpalan/ pengisaran | 用于焊接/ 打磨工作

- Strong in heat and sparks

DFJ411ZM | DFJ411ZL | DFJ411ZXL 18V / 12Vmax

Cordless Fan Jacket
Jaket Kipas Tanpa Kord
充电式风扇外套



- Equipped with Two Flat Fan Units with BL Motor for Increased Comfort

• Without Charger & Battery



Air Flow Settings Tetapan Aliran Udara 空气流量设置	Turbo High Medium Low
Air Flow Aliran Udara 空气流量	Turbo: 2.2m³/min High: 2.1m³/min Med: 1.7m³/min Low: 1.5m³/min
Size Saiz 尺寸	M L XL
Pockets Poket 口袋	5
Net Weight Berat Bersih 淨重	0.49kg (1.1lbs.)
Continuous Usage Time (approx.) Masa Penggunaan Berterusan 连续使用时间	Low: 29 hrs Medium: 21 hrs High: 12 hrs with BL1850B

Polyester + Titanium coating For outdoor work
Untuk kerja luaran | 用于户外工作

- Reflective in ultraviolet rays and infrared rays

* All list price shown are for reference only (exclude SST).

* Semua harga yang ditunjukkan adalah untuk rujukan sahaja (tidak termasuk SST). 所有显示的建议零售价仅供参考 (不包括SST)。



FJ502DZM | FJ502DZL | FJ502DZLL 18V / 12Vmax

Cordless Fan Jacket
Jaket Kipas Tanpa Kord
充电式风扇外套

- Equipped with Two Flat Fan Units with BL Motor for Increased Comfort

M / L / LL



- Without Charger & Battery



Air Flow Settings Tetapan Aliran Udara 空气流量设置	Turbo High Medium Low
Air Flow Aliran Udara 空气流量	Turbo: 2.2m ³ /min High: 2.1m ³ /min Med: 1.7m ³ /min Low: 1.5m ³ /min
Size Saiz 尺寸	M L LL

DFJ214OM | DFJ214OL | DFJ214OXL | DFJ214O2XL 18V / 12Vmax

Cordless Fan Jacket
Jaket Kipas Tanpa Kord
充电式风扇夹克

- Equipped with Two Flat Fan Units with BL Motor for Increased Comfort

M / L / XL / 2XL



- Without Charger & Battery



Air Flow Settings Tetapan Aliran Udara 空气流量设置	Turbo High Medium Low
Air Flow Aliran Udara 空气流量	Turbo: 2.2m ³ /min High: 2.1m ³ /min Med: 1.7m ³ /min Low: 1.5m ³ /min
Size Saiz 尺寸	M L XL 2XL
Pockets Poket 口袋	5
Net Weight Berat Bersih 净重	0.54kg (1.2lbs.)
Continuous Usage Time (approx.) Masa Penggunaan Berterusan 连续使用时间	Low: 27.5 hrs Medium : 20 hrs High: 11 hrs with BL1850B

Polyester

- water repellency, antistatic fabric

DFJ214ZM | DFJ214ZL | DFJ214ZXL 18V / 12Vmax

Cordless Fan Jacket
Jaket Kipas Tanpa Kord
充电式风扇外套



- Equipped with Two Flat Fan Units with BL Motor for Increased Comfort

M / L / XL



- Without Charger & Battery



Air Flow Settings Tetapan Aliran Udara 空气流量设置	Turbo High Medium Low
Air Flow Aliran Udara 空气流量	Turbo: 2.2m ³ /min High: 2.1m ³ /min Med: 1.7m ³ /min Low: 1.5m ³ /min
Size Saiz 尺寸	M L XL
Pockets Poket 口袋	5
Net Weight Berat Bersih 净重	0.54kg (1.2lbs.)
Continuous Usage Time (approx.) Masa Penggunaan Berterusan 连续使用时间	Low: 27.5 hrs Medium : 20 hrs High: 11 hrs with BL1850B

Polyester

- water repellency, antistatic fabric

DFJ212ZM | DFJ212ZL | DFJ212ZXL 18V / 12Vmax

Cordless Fan Jacket
Jaket Kipas Tanpa Kord
充电式风扇外套



- Equipped with Two Flat Fan Units with BL Motor for Increased Comfort

M / L / XL



- Without Charger & Battery



Air Flow Settings Tetapan Aliran Udara 空气流量设置	Turbo High Medium Low
Air Flow Aliran Udara 空气流量	Turbo: 2.2m ³ /min High: 2.1m ³ /min Med: 1.7m ³ /min Low: 1.5m ³ /min
Size Saiz 尺寸	M L XL
Pockets Poket 口袋	5
Net Weight Berat Bersih 净重	0.43kg (0.9lbs.)
Continuous Usage Time (approx.) Masa Penggunaan Berterusan 连续使用时间	Low: 29 hrs Medium : 21 hrs High: 12 hrs with BL1850B

Polyester

- High repellency fabric

DFJ213ZM | DFJ213ZL | DFJ213ZXL 18V / 12Vmax

Cordless Fan Jacket
Jaket Kipas Tanpa Kord
充电式风扇外套



- Equipped with Two Flat Fan Units with BL Motor for Increased Comfort

M / L / XL



- Without Charger & Battery



Air Flow Settings Tetapan Aliran Udara 空气流量设置	Turbo High Medium Low
Air Flow Aliran Udara 空气流量	Turbo: 2.2m ³ /min High: 2.1m ³ /min Med: 1.7m ³ /min Low: 1.5m ³ /min
Size Saiz 尺寸	M L XL
Pockets Poket 口袋	5
Net Weight Berat Bersih 净重	0.54kg (1.2lbs.)
Continuous Usage Time (approx.) Masa Penggunaan Berterusan 连续使用时间	Low: 29 hrs Medium : 21 hrs High: 12 hrs with BL1850B

Polyester

- Stretchable fabric

* All list price shown are for reference only (exclude SST).

* Semua harga yang ditunjukkan adalah untuk rujukan sahaja (tidak termasuk SST). 所有显示的建议零售价仅供参考 (不包括SST)。

Cordless
Target Area Jacket

LED Flashlight
Lampu Suhu LED
LED 手电筒

Vacuum Cleaner
Pembersih Vakuum
吸尘器

Drilling / Fastening
Gantut / Pengikat
钻孔 / 紧固

Impact Drilling / Demolition
Gantut / Persekit
冲击钻孔 / 拆除

Cutting
Pemotong
切割

Grinding / Sanding
Pengisar / Pasir
研磨 / 打磨

Sawing
Gergaji
锯切

Planing / Routing
Pengisar / Tanggapan
刨削 / 雕刻

Others
Lain-lain
其他

Outdoor Power Equipment
Alatan Kuat Luar
户外动力





Cordless Target Kord 无绳式
LED Flashlight Lampu Suluh LED LED 照明灯
Vacuum Cleaner Pembersih Vakuum 吸尘器
Drilling / Fastening Druai / Penamok 钻孔 / 紧固
Impact Drilling / Demolition Druai / Penamok 冲击钻孔 / 拆除加工
Cutting Pemotong 切割
Grinding / Sanding Pengisar / Poles 研磨 / 打磨
Sawing Gergaji 电锯
Planing / Routing Pengisar / Tangkapan 刨削 / 雕刻
Others Lain-lain 其他
Outdoor Power Equipment Alatan Kerja Luar 园林-户外

DFV214A01 | DFV214A02 18V / 12Vmax

Cordless Fan Vest
Jaket Kipas Tanpa Kord
充电式风扇背心



• Two flatter fan units, higher voltage and redesigned air flow for increased air volume and comfort

• Without Charger & Battery

DFV214A01 (S-L)
DFV214A02 (XL-3L)



Air Flow Settings Tetapan Aliran Udara 空气流量设置	Turbo High Medium Low
Size Saiz 尺寸	01: S-L 02: XL-3L
Pockets Poket 口袋	4
Net Weight Berat Bersih 淨重	0.23kg
Continuous Usage Time (approx.) Masa Penggunaan Berterusan 连续使用时间	Low: 68 hrs Medium : 29.5 hrs High: 16 hrs Max: 10 hrs with BL1860B

Polyester

• High repellency fabric

DFV210ZM | DFV210ZL | DFV210ZX | DFV210Z2XL 18V / 12Vmax

Cordless Fan Vest
Jaket Kipas Tanpa Kord
充电式风扇背心



• Equipped with Two Flat Fan Units with BL Motor for Increased Comfort

• Without Charger & Battery

M / L / XL / 2XL



Air Flow Settings Tetapan Aliran Udara 空气流量设置	Turbo High Medium Low
Air Flow Aliran Udara 空气流量	Turbo: 2.2m³/min High: 2.1m³/min Med: 1.7m³/min Low: 1.5m³/min
Size Saiz 尺寸	M L XL
Pockets Poket 口袋	5
Net Weight Berat Bersih 淨重	0.38kg (0.8lbs.)
Continuous Usage Time (approx.) Masa Penggunaan Berterusan 连续使用时间	Low: 29 hrs Medium: 21 hrs High: 12 hrs with BL1850B

Polyester

• High repellency fabric

FJ203DZL | FJ203DZLL 18V / 12Vmax

Cordless Fan Jacket
Jaket Kipas Tanpa Kord
充电式风扇外套



• Powerful fan provides air flow to keep you cool

Standard Equipment: Fan Hook

• Without Charger & Battery



L / LL

Air Flow Settings Tetapan Aliran Udara 空气流量设置	Turbo High Medium Low
Air Flow Aliran Udara 空气流量	Turbo: 1.4m³/min High: 1.2m³/min Med: 1.0m³/min Low: 0.8m³/min
Size Saiz 尺寸	L XL LL
Pockets Poket 口袋	5
Net weight Berat Bersih 淨重	1.5 - 1.9kg (3.3 - 4.1lbs)
Continuous Usage Time (approx.) Masa Penggunaan Berterusan 连续使用时间	Low: 28 hrs Medium: 20 hrs High: 11 hrs with BL1850B

Polyester

For general work

Untuk kerja am | 用于一般工作

• Superior moisture permeability and water repellent

DFJ300ZXL | FJ301DZM | FJ301DZL | FJ301DZLL 18V / 12Vmax

Cordless Fan Jacket
Jaket Kipas Tanpa Kord
充电式风扇外套



• 100% cotton - hardly-burned, suitable for welding/ grinding

Standard Equipment: Fan Hook

• Without Charger & Battery



DFJ300ZXL

FJ301DZM / L / LL

Air Flow Settings Tetapan Aliran Udara 空气流量设置	Turbo High Medium Low
Air Flow Aliran Udara 空气流量	Turbo: 1.4m³/min High: 1.2m³/min Med: 1.0m³/min Low: 0.8m³/min
Size Saiz 尺寸	DFJ300: XL FJ301: M L LL
Pockets Poket 口袋	5
Net weight Berat Bersih 淨重	1.5 - 1.9kg (3.3 - 4.1lbs)
Continuous Usage Time (approx.) Masa Penggunaan Berterusan 连续使用时间	Low: 29 hrs Medium: 21 hrs High: 12 hrs with BL1850B

Cotton

For welding/ grinding work

Untuk kerja kimpalan/ pengisaran | 用于焊接/ 打磨工作

• Strong in heat and sparks

DFJ400ZXL | FJ401DZL | FJ401DZLL | FJ401DZ3L 18V / 12Vmax

Cordless Fan Jacket
Jaket Kipas Tanpa Kord
充电式风扇外套



• Heavy-duty shoulder pad lightens the burden on a shoulder and prevents torn while carrying reinforcing bars

Standard Equipment: Fan Hook

• Without Charger & Battery



DFJ400ZXL

FJ401DZL / LL / 3L

Air Flow Settings Tetapan Aliran Udara 空气流量设置	Turbo High Medium Low
Air Flow Aliran Udara 空气流量	Turbo: 1.4m³/min High: 1.2m³/min Med: 1.0m³/min Low: 0.8m³/min
Size Saiz 尺寸	DFJ400: XL FJ401: L LL 3L
Pockets Poket 口袋	5
Net weight Berat Bersih 淨重	1.5 - 1.9kg (3.3 - 4.1lbs)
Continuous Usage Time (approx.) Masa Penggunaan Berterusan 连续使用时间	Low: 28 hrs Medium: 20 hrs High: 11 hrs with BL1850B

Polyester + Titanium processing

For outdoor work

Untuk kerja luaran | 用于户外工作

• Reflective in ultraviolet rays and infrared rays

* All list price shown are for reference only (exclude SST).

* Semua harga yang ditunjukkan adalah untuk rujukan sahaja (tidak termasuk SST). 所有显示的建议零售价仅供参考 (不包括SST)。



18V

LXT

12Vmax

CXT

Li-ion Ah 6.0 5.0 4.0 3.0 2.0 1.5

DCV202YXL 18V

Cordless Heated Vest
Ves Pemanas Tanpa Kord
充电式发热背心



- Stay warm in cold harsh job site environments

XL

- Without Charger & Battery

Heat Zones Tetapan Aliran Udara 發熱區域	Total: 4 Chest: 2 Back: 2
Heat Settings Aliran Udara 加熱設定	High Medium Low
Heat Value Aliran Udara 加熱值	High: 9.5W Mid : 4.5W Low: 2.3W
Size Saiz 尺寸	XL
Pockets Poket 口袋	4
Net Weight Berat Bersih 淨重	0.5kg (1.1lbs.)
Continuous Usage Time (approx.) Masa Penggunaan Berterusan 连续使用时间	Low: 29 hrs Medium: 17 hrs High: 8 hrs with BL1850B

Polyester

- High repency fabric

Cordless Heated Blanket

1.5m Extension Cord



Continuous Usage Time
with BL1850B
(Low Mode)

29hrs
(approx.)



Power Button

To turn on the blanket, press and hold the power button for a few seconds. To turn off, press and hold the power button again

Temperature Adjustment

There are three temperature settings (high, medium, low)

*Continuous runtime on a single full battery charge with BL1860B (18V-6.0Ah Battery)

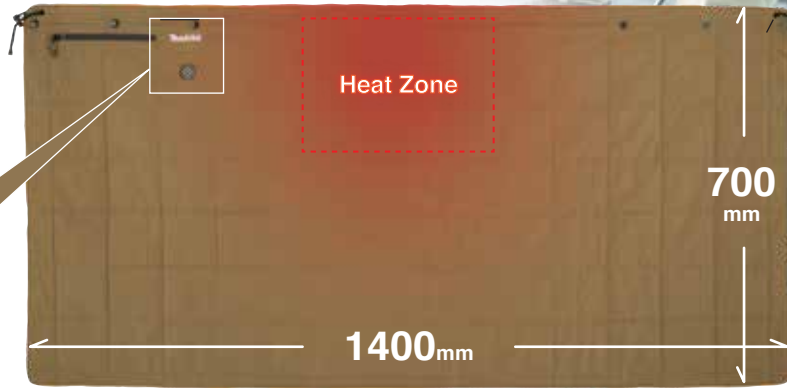

Washable & Dryable

Be sure to remove the battery holder from the blanket before washing and drying

DCB200B 18V

Cordless Heated Blanket
Selimut Elektrik Tanpa Kord
充电式电热毯



- Machine-washable and machine-dryable

Standard Equipment: Battery Holder, Storage Bag, Extension Cord

- Without Charger & Battery

Heat Zone Tetapan Aliran Udara 發熱區域	Upper Center: 1
Heat Settings Aliran Udara 加熱設定	High Medium Low
Heat Value Aliran Udara 加熱值	High: 9.5W Med: 4.5W Low: 2.3W
Dimensions (L x W) Dimensi 体积	700x1,400mm (27-1/2"x55")
Net Weight Berat Bersih 淨重	0.58kg (1.28lbs.)
Continuous Usage Time (approx.) Masa Penggunaan Berterusan 连续使用时间	Low: 29 hrs Med: 16.5 hrs High: 8 hrs with BL1850B

CB100DB 12Vmax

Cordless Heated Blanket
Selimut Elektrik Tanpa Kord
充电式电热毯



- Machine-washable and machine-dryable

Standard Equipment: Battery Holder, Storage Bag, Extension Cord

- Without Charger & Battery

Heat Zone Tetapan Aliran Udara 發熱區域	Upper Center: 1
Heat Settings Aliran Udara 加熱設定	High Medium Low
Heat Value Aliran Udara 加熱值	High: 9.5W Med: 4.5W Low: 2.3W
Dimensions (L x W) Dimensi 体积	700x1,400mm (27-1/2"x55")
Net Weight Berat Bersih 淨重	0.58kg (1.28lbs.)
Continuous Usage Time (approx.) Masa Penggunaan Berterusan 连续使用时间	Low: 14 hrs Med: 7.5 hrs High: 4 hrs with BL1041B

* All list price shown are for reference only (exclude SST).

* Semua harga yang ditunjukkan adalah untuk rujukan sahaja (tidak termasuk SST). 所有显示的建议零售价仅供参考 (不包括SST)。

Cordless
Target Area 3.0Ah

LED Flashlight
Lampu Saku LED
LED手电筒

Vacuum Cleaner
Pembersih Vakuum
吸尘器

Drilling / Fastening
Gantol / Pengikat
钻孔 / 紧固

Impact Drilling / Demolition
Gantol / Pemukul
冲击钻孔 / 拆墙工具

Cutting
Pemotong
切割

Grinding / Sanding
Pengkilan / Pengkilan
打磨 / 砂磨

Sawing
Gergaji
锯切

Planing / Routing
Pengkilan / Tergantol
刨平 / 磨边

Others
Lain-lain
其他

Outdoor Power Equipment
Alatan Kuat Luar
户外动力工具

Makita
工具

LED FLASHLIGHT

Lampu Suluh LED LED照明灯

Cordless
Tangan Kordless

LED Flashlight
Lampu Suluh LED
LED照明灯

Vacuum Cleaner
Pembersih Vakuum
吸尘器

Drilling | Fastening
Gores | Pengetat
钻孔 | 紧固

Impact Drilling | Demolition
Gores | Pencah
冲击钻孔 | 拆除加工

Cutting
Pemotongan
切割

Grinding | Sanding
Pengam | Pasah
打磨 | 打磨

Sawing
Gergaji
锯切

Planing | Routers
Pengaliran | Routers
刨削 | 雕刻

Others
Lain-lain
其他

Outdoor Power Equipment
Alat-alat Kerja Luar
园具-户外



Distance*

Long-distance irradiation

640m

Spot mode

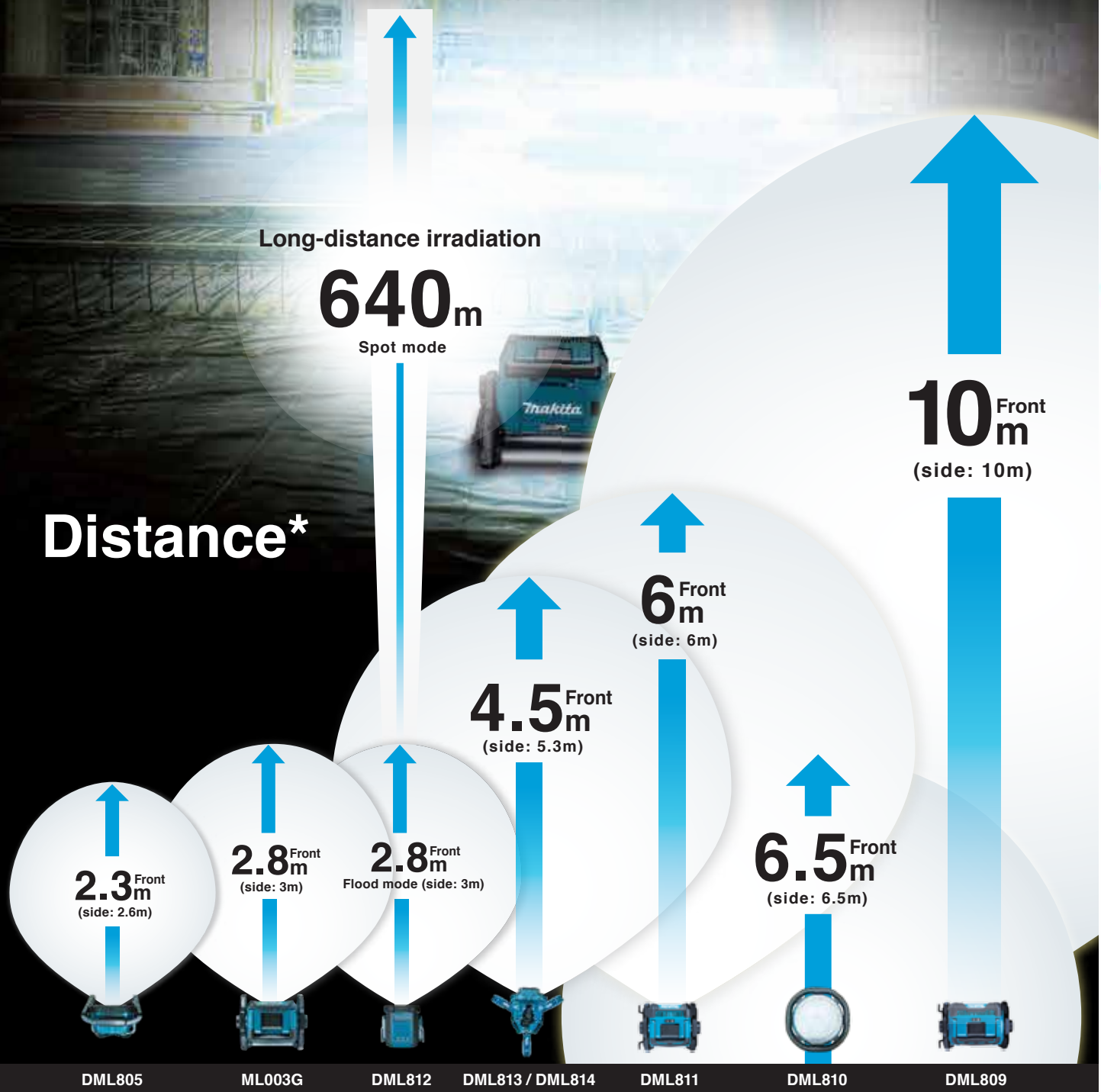

DML805

ML003G

DML812

DML813 / DML814

DML811

DML810

DML809

*measured in accordance with ANSI

Luminous flux



Cordless
Tethered 1000mAh

LED Flashlight
Lampu Senter LED
LED 3000lm

Vacuum Cleaner
Pembersih Vakuam
吸尘器

Drilling / Fastening
Gabus / Penggulat
钻头 / 紧固件

Impact Drilling / Demolition
Gabus / Pemecah
冲击钻头 / 拆除工具

Cutting
Pemotong
切割机

Grinding / Sanding
Penghalus / Pasir
打磨 / 砂磨

Sawing
Gergaji
电锯

Planing / Routing
Penghalus / Tumpang
刨平 / 雕刻

Others
Lain-lain
其他

Outdoor Power Equipment
Alat-alat Listrik
户外电源设备





DML813 (MYADML813) 18V

Cordless Worklight
Lampu Kerja Tanpa Kord
充电式工作灯



18V

- LED color is daylight white, which is similar to the natural light and ideal for working spaces



Spot lighting



Standard Equipment: Shoulder Belt, Tool Bag

- Without Charger & Battery

Luminous Flux Cahaya Fluks 发光通量	High: 3,000 Mid: 1,700 Low: 900 lm
Illuminance Pencahayaannya 照度	at 1m from the light source: High: 1,250 Mid: 750 Low: 400 lx at 3m from the light source: High: 130 Mid: 80 Low: 40 lx at 5m from the light source: High: 50 Mid: 30 Low: 15 lx Front: 4.5m Sides: 5.3m
Lighting Coverage Liputan Pencahayaannya 照明覆盖	
Dimensions (L x W x H) Dimensi 体积	Folding Position: 260x216x1,000mm (10-1/4x8-1/2x39-3/8") Operating Position (Max Height): 573x658x1,250 - 2,240mm (22-1/2x26x49-1/4-88")
Net Weight Berat Bersih 净重	7.2 - 7.9kg (15.9 - 17.4lbs.)
Continuous Usage Time (approx.) Masa Penggunaan Berterusan 连续使用时间	Low: 10 hrs Med: 5.5 hrs High: 3 hrs with BL1850B

DML814 (MYADML814) 18V

Cordless Worklight
Lampu Kerja Tanpa Kord
充电式工作灯



18V

- LED color is daylight white, which is similar to the natural light and ideal for working spaces



Spot lighting



Area lighting



Standard Equipment: Shoulder Belt, Tool Bag

- Without Charger & Battery

Luminous Flux Cahaya Fluks 发光通量	High: 3,000 Mid: 1,700 Low: 900 lm
Illuminance Pencahayaannya 照度	at 1m from the light source: High: 1,250 Mid: 750 Low: 400 lx at 3m from the light source: High: 130 Mid: 80 Low: 40 lx at 5m from the light source: High: 50 Mid: 30 Low: 15 lx Front: 4.7m Sides: 5.6m
Lighting Coverage Liputan Pencahayaannya 照明覆盖	
Dimensions (L x W x H) Dimensi 体积	Folding Position: 260x216x1,000mm (10-1/4x8-1/2x39-3/8") Operating Position (Max Height): 573x658x1,250 - 2,240mm (22-1/2x26x49-1/4-88")
Net Weight Berat Bersih 净重	7.4 - 8.1kg (16.3 - 17.9lbs.)
Continuous Usage Time (approx.) Masa Penggunaan Berterusan 连续使用时间	Low: 10 hrs Med: 5.5 hrs High: 3 hrs with BL1850B

DML810 18V / AC

Cordless Area Worklight
Lampu Kerja Kawasan Tanpa Kord
充电式区域工作灯



18V



- Self-righting design won't fall over even if bumped



Standard Equipment: AC Power Cord

- Without Charger & Battery

Luminous Flux Cahaya Fluks 发光通量	High: 5,500lm Mid: 3,000lm Low: 1,500lm
Illuminance Pencahayaannya 照度	at 1m from the light source: 550 / 300 / 150 lx at 3m from the light source: 70 / 40 / 20 lx at 5m from the light source: 25 / 15 / 7 lx
Dimensions (L x W x H) Dimensi 体积	420x420x787mm (16-1/2"x16-1/2"x31")
Net Weight Berat Bersih 净重	13.9 - 15.3kg (30.6 - 33.7lbs.)
Continuous Usage Time (approx.) Masa Penggunaan Berterusan 连续使用时间	18 hrs with BL1850B x2

ML003G (TWAML003G) 40Vmax / 18V

Cordless Worklight
Lampu Kerja Tanpa Kord
充电式工作灯



40Vmax

18V

- IP65 rated for maximum weather and water resistance suitable for jobsite use



- Without Charger & Battery



Luminous Flux Cahaya Fluks 发光通量	High: 1,100lm Low: 450lm
Illuminance Pencahayaannya 照度	at 1m from the light source High: 500lx Low: 200lx
Dimensions (L x W x H) Dimensi 体积	249x298x280mm (9-3/4x11-3/4x11")
Net Weight Berat Bersih 净重	3.7 - 4.7kg (8.2 - 10.4lbs.)
Continuous Usage Time (approx.) Masa Penggunaan Berterusan 连续使用时间	High: 10 hrs Low: 22 hrs with BL4040

DML809 (GBDDML809) 18V / AC

Cordless Worklight
Lampu Kerja Tanpa Kord
充电式工作灯



18V



- 96 super luminous daylight white LEDs



Standard Equipment: AC Power Cord

- Without Charger & Battery



Luminous Flux Cahaya Fluks 发光通量	High: 10,000lm Mid: 4,000lm Low: 2,000lm
Illuminance Pencahayaannya 照度	at 1m from the light source: 3,800 / 1,500 / 800 lx at 3m from the light source: 380 / 150 / 80 lx at 5m from the light source: 150 / 60 / 30 lx
Dimensions (L x W x H) Dimensi 体积	249x370x278mm (9-3/4x14-1/2x11")
Net Weight Berat Bersih 净重	5.7 - 7.0 kg (12.6 - 15.4 lbs.)
Continuous Usage Time (approx.) Masa Penggunaan Berterusan 连续使用时间	8.5 hrs with BL1860B x2 Low mode

* All list price shown are for reference only (exclude SST).

* Semua harga yang ditunjukkan adalah untuk rujukan sahaja (tidak termasuk SST). 所有显示的建议零售价仅供参考 (不包括SST)。

Cordless
Tanpa Kord 无线式

LED Flashlight
Lampu Suhu LED
LED 照明灯

Vacuum Cleaner
Pembersih Vakuum
吸尘器

Drilling / Fastening
Gores / Pengikat
钻孔 / 紧固

Impact Drilling / Demolition
Gores / Pencah
冲击钻孔 / 拆除加工

Cutting
Memotong
切割

Grinding / Sanding
Pengam / Pasah
打磨 / 研磨

Sawing
Mengaji
锯切

Planing / Routing
Pengam / Tumpang
刨削 / 雕刻

Others
Lain-lain
其他

Outdoor Power Equipment
Alat-alat Kerja Luar
园具-户外

Makita
makita



DML811 (GBDDML811) 18V / AC

Cordless Worklight
Lampu Kerja Tanpa Kord
充电式工作灯



- 30 super luminous daylight white LEDs

Standard Equipment: AC Power Cord

- Without Charger & Battery

Luminous Flux Cahaya Fluks 发光通量	High: 3,000lm Mid: 1,500lm Low: 750lm
illuminance Pencahayaannya 照度	at 1m from the light source: 1,800 / 800 / 350 lx at 3m from the light source: 200 / 100 / 40 lx at 5m from the light source: 85 / 40 / 17 lx
Dimensions (L x W x H) Dimensi 体积	249x302x271mm (9-3/4x11-7/8x10-5/8")
Net Weight Berat Bersih 淨重	4.1 - 4.8kg (9.0 - 10.5lbs.)
Continuous Usage Time (approx.) Masa Penggunaan Berterusan 连续使用时间	13 hrs with BL1860B Low mode

DML805 (GBDDML805) 18V / AC

Cordless and Cordless LED Worklight
Lampu Kerja LED Kuasa Elektrik dan Tanpa Kord
电源及充电式LED工作灯



- 2-mode operation: delivers 750 lumens on high mode or 450 lumens on low mode

- Without Charger & Battery

Luminous Flux Cahaya Fluks 发光通量	Hi: 750lm, Lo: 450lm
illuminance Pencahayaannya 照度	at 0.5m from the light source Hi: 1,150lx, Lo: 750lx at 1m from the light source Hi: 300lx, Lo: 200lx
Dimensions (L x W x H) Dimensi 体积	214x261x328mm (8-3/8"x10-1/4"x12-7/8")
Net Weight Berat Bersih 淨重	2.3 - 2.7kg (5.1 - 5.9lbs)
Continuous Usage Time (approx.) Masa Penggunaan Berterusan 连续使用时间	10.5 hrs with BL1850B

ML007G (TWAML007G)

Cordless Flashlight
Lampu Suluh Tanpa Kord
充电式工作灯



- Bright light with a max luminous flux of 1,250lm

Standard Equipment: Hand strap

- Without Charger & Battery



Luminous Flux Cahaya Fluks 发光通量	Spot: 600lm Flood: 1,000lm Spot-Flood: 1,250lm
illuminance Pencahayaannya 照度	Spot: 82,000lx Flood: 520lx Spot-Flood: 60,000lx
Dimensions (L x W x H) Dimensi 体积	330x120x133mm (13x4-3/4x5-1/4")
Net Weight Berat Bersih 淨重	1.6 - 2.9kg (3.5 - 6.4lbs.)
Continuous Usage Time (approx.) Masa Penggunaan Berterusan 连续使用时间	Spot mode: 10 hrs Spot-Flood mode: 7.5 hrs Flood mode: 10 hrs Strobe mode: 10 hrs with BL4040

DML812 (TWADML812) 18V

Cordless Flashlight
Lampu Suluh Tanpa Kord
充电式工作灯



- Super luminous daylight white LEDs

Standard Equipment: Strap Hook

- Without Charger & Battery



Luminous Flux Cahaya Fluks 发光通量	Spot: 600 lm Flood: 1,000 lm Spot-Flood: 1,250 lm
illuminance Pencahayaannya 照度	Spot: 71,000 lx Flood: 520 lx Spot-Flood: 51,000 lx
Dimensions (L x W x H) Dimensi 体积	313x119x115mm (12-3/8"x4-11/16"x4-1/2")
Net Weight Berat Bersih 淨重	1.2 - 1.6kg (2.6 - 3.4lbs.)
Continuous Usage Time (approx.) Masa Penggunaan Berterusan 连续使用时间	Spot: 8.5 hrs Flood: 6.5 hrs Spot-Flood: 5.0 hrs Strobe: 7.0 hrs with BL1850B

ML001G (AUAML001G) 40Vmax

Cordless LED Flashlight
Lampu Suluh LED Tanpa Kord
充电式LED照明灯



- 12 position pivoting flashlight head with positive stops from 0° - 170°

Standard Equipment: Strap Hook

- Without Charger & Battery



Luminous Flux Cahaya Fluks 发光通量	160lm
illuminance Pencahayaannya 照度	at 1m from the light source: 3,000lx
Dimensions (L x W x H) Dimensi 体积	281x88x121mm (11-1/8x3-1/2x4-3/4")
Net Weight Berat Bersih 淨重	1.0 - 1.3kg (2.2 - 2.9lbs.)
Continuous Usage Time (approx.) Masa Penggunaan Berterusan 连续使用时间	55 hrs with BL4040

* All list price shown are for reference only (exclude SST).

* Semua harga yang ditunjukkan adalah untuk rujukan sahaja (tidak termasuk SST). 所有显示的建议零售价仅供参考 (不包括SST)。

Cordless
Tempa Kord 充电式

LED Flashlight
Lampu Suluh LED
LED 照明灯

Vacuum Cleaner
Penyedut A Vakuum
吸尘器

Drilling | Fastening
Gergaji | Pasang
电钻 | 紧固

Impact Drilling | Demolition
Gergaji | Pecahkan
电钻 | 拆毁

Cutting
Pemotong
切割

Grinding | Sanding
Pengkilan | Pasir
打磨 | 砂磨

Sawing
Gergaji
锯切

Planing | Routing
Meyakam | Tumpang
刨削 | 镶嵌

Others
Lain-lain
其他

Outdoor Power Equipment
Alatan Kerja Luar
户外动力设备



40V^{Li-ion}max **XGT**

18V

LXT

12V^{max}

CXT

DML815 (AUADML815) 18V

Cordless LED Flashlight
Lampu Suluh LED Tanpa Kord
充电式LED工作灯



18V



- 12 position pivoting flashlight head with positive stops from 0° - 170°

Standard Equipment: Strap Hook

- Without Charger & Battery

Luminous Flux Cahaya Fluks 发光通量	160lm
Illuminance Pencahayaann 照度	at 1m from the light source: 3,000lx
Dimensions (L x W x H) Dimensi 体积	272x79x116mm (10-3/4x3-1/8x4-9/16")
Net Weight Berat Bersih 淨重	0.26 - 0.93kg (0.57 - 2.05lbs.)
Continuous Usage Time (approx.) Masa Penggunaan Berterusan 连续使用时间	54 hrs with BL1860B

DML808 (AUADML808) 18V

Cordless LED Flashlight
Lampu Suluh LED Tanpa Kord
充电式LED工作灯



18V



- Multifaceted Reflector Illuminates Evenly for Increased Visibility

- Without Charger & Battery

Luminous Flux Cahaya Fluks 发光通量	190lm
Illuminance Pencahayaann 照度	at 1m from the light source 170 - 4,500lx
Dimensions (L x W x H) Dimensi 体积	297x79x119mm (11-3/4"x3-1/8"x4-11/16")
Net Weight Berat Bersih 淨重	0.73 - 1.09kg (1.6 - 2.4lbs)
Continuous Usage Time (approx.) Masa Penggunaan Berterusan 连续使用时间	26 hrs with BL1850B



DML808/ML106
Models and specs may vary by country

ML106 (AUAML106) 12V^{max}

Cordless LED Flashlight
Lampu Suluh LED Tanpa Kord
充电式LED工作灯



12V^{max}



- Multifaceted Reflector Illuminates Evenly for Increased Visibility

Standard Equipment: Strap Hook

- Without Charger & Battery

Luminous Flux Cahaya Fluks 发光通量	190lm
Illuminance Pencahayaann 照度	at 1m from the light source 170 - 4,500lx
Dimensions (L x W x H) Dimensi 体积	271x66x93mm (10-5/8"x2-5/8"x3-5/8")
Net Weight Berat Bersih 淨重	0.61 - 0.78kg (1.3 - 1.7lbs)
Continuous Usage Time (approx.) Masa Penggunaan Berterusan 连续使用时间	6 hrs with BL1021B



DML808/ML106
Models and specs may vary by country

ML105 (AUAML105) 12V^{max}

Cordless LED Flashlight
Lampu Suluh LED Tanpa Kord
充电式LED工作灯



12V^{max}



- Multifaceted Reflector Illuminates Evenly for Increased Visibility

Standard Equipment: Strap Hook

- Without Charger & Battery

Luminous Flux Cahaya Fluks 发光通量	190lm
Illuminance Pencahayaann 照度	at 1m from the light source 5,500lx
Dimensions (L x W x H) Dimensi 体积	249x66x93mm (9-3/4"x2-5/8"x3-5/8")
Net Weight Berat Bersih 淨重	0.53 - 0.70kg (1.2 - 1.5lbs.)
Continuous Usage Time (approx.) Masa Penggunaan Berterusan 连续使用时间	7 hrs with BL1021B

ML002G (TWAML002G) 40V^{max}

Cordless LED Worklight
Lampu Kerja LED Tanpa Kord
充电式LED工作灯



40V^{max}



- Without Charger & Battery

XGT XPT

Main Light (on bar side) Lampu Utama 主灯	Luminous flux (Full brightness): 710lm illumiance (Full brightness): 340lx Luminous flux (Half brightness): 340lx illumiance (Half brightness): 310lx
Sub Light (on top side) Lampu Tambahan 副灯	Luminous flux: 130lm illumiance: 1,900lx
Dimensions (L x W x H) Dimensi 体积	376x86x126mm (14-3/4x3-3/8x5")
Net Weight Berat Bersih 淨重	1.2 - 1.5kg (2.7 - 3.3lbs.)
Continuous Usage Time (approx.) Masa Penggunaan Berterusan 连续使用时间	51 hrs with BL4040

* All list price shown are for reference only (exclude SST).

* Semua harga yang ditunjukkan adalah untuk rujukan sahaja (tidak termasuk SST). 所有显示的建议零售价仅供参考 (不包括SST)。

Cordless
Tanpa Kord 无线式

LED Flashlight
Lampu Suluh LED
LED工作灯

Vacuum Cleaner
Pembersih Vakuum
吸尘器

Drilling / Fastening
Gores / Pengesat
钻孔 / 紧固

Impact Drilling / Demolition
Gores / Pencah
冲击钻孔 / 拆除加工

Cutting
Pemesat
切割

Grinding / Sanding
Pengam / Pasah
打磨 / 打磨

Sawing
Gores
切割

Planing / Routing
Pengalam / Tenggam
刨削 / 雕刻

Others
Lain-lain
其他

Outdoor Power Equipment
Alat-alat Kerja Luar
园具-户外

Makita
makita



DML807 (AUBDML807) 18V

Cordless LED Flashlight

Lampu Suluh LED Tanpa Kord
充电式LED手电筒



18V

- USB power supply switch with auto-off function for saving battery power

• Without Charger & Battery



Main light (on bar side)

Lampu Utama 主灯

Luminous flux (Full brightness): 710 lm
Illuminance (Full brightness): 340 lx
Luminous flux (Half brightness): 340 lm
Illuminance (Half brightness): 310 lx

Sub light (on top side)

Lampu Tambahan 副灯

Luminous flux: 130 lm
Illuminance: 1,900 lx

Dimensions (L x W x H)

Dimensi 体积

414x79x155mm
(16-1/4"x3-1/8"x6-1/8")

Net Weight

Berat Bersih 净重

0.72 - 1.1kg (1.6 - 2.4lbs.)

Continuous Usage Time (approx.)

Masa Penggunaan Berterusan 连续使用时间

43 hrs with BL1850B

ML104 (AUAML104) 12Vmax

Cordless LED Flashlight

Lampu Suluh LED Tanpa Kord
充电式LED手电筒

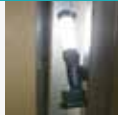

12Vmax

- USB power supply switch with auto-off function for saving battery power

• Without Charger & Battery



Main light (on bar side)

Lampu Utama 主灯

Luminous flux (Full brightness): 710 lm
Illuminance (Full brightness): 340 lx

Sub light (on top side)

Lampu Tambahan 副灯

Luminous flux: 130 lm
Illuminance: 1,900 lx

Dimensions (L x W x H)

Dimensi 体积

414x66x132mm
(16-1/4"x2-5/8"x5-3/16")

Net Weight

Berat Bersih 净重

0.61 - 0.78 kg (1.4 - 1.7 lbs.)

Continuous Usage Time (approx.)

Masa Penggunaan Berterusan 连续使用时间

19 hrs with BL1041B

ML006GX

Cordless Flashlight

Lampu Suluh Tanpa Kord
充电式工作灯



40Vmax

- Extra Bright 18 LED Flashlight Provides 500 Lumens

Standard Equipment: *Shoulder Strap*

• Without Charger & Battery



Luminous Flux

Cahaya Fluks 发光通量

High: 500 | Mid: 250 | Low: 100 lm

Illuminance

Pencahayaann 照度

at 0.5m from the light source:
High: 800 | Mid: 400 | Low: 180 lx

Dimensions (L x W x H)

Dimensi 体积

275 - 408x85x148mm
(10-7/8-16x3-3/8x5-7/8")

Net Weight

Berat Bersih 净重

1.1 - 1.7kg (2.4 - 3.8lbs.)

Continuous Usage Time (approx.)

Masa Penggunaan Berterusan 连续使用时间

Low: 82 hrs | Med: 40 hrs |
High: 20 hrs with BL4040

DML816X

Cordless Flashlight

Lampu Suluh Tanpa Kord
充电式工作灯

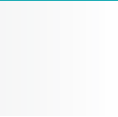

18V

- Extra Bright 18 LED Flashlight Provides 500 Lumens

Standard Equipment: *Shoulder Strap*

• Without Charger & Battery



Luminous Flux

Cahaya Fluks 发光通量

High: 500 | Mid: 250 | Low: 100 lm

Illuminance

Pencahayaann 照度

at 0.5m from the light source:
High: 800 | Mid: 400 | Low: 180 lx

Dimensions (L x W x H)

Dimensi 体积

267 - 400x79x127mm
(10-1/2-15-3/4x3-1/8x5")

Net Weight

Berat Bersih 净重

0.70 - 1.1kg (1.5 - 2.4lbs.)

Continuous Usage Time (approx.)

Masa Penggunaan Berterusan 连续使用时间

Low: 75 hrs | Med: 34 hrs |
High: 17 hrs with BL1860B

DML801 (DEBDML801) 18V

Cordless LED Flashlight

Lampu Suluh LED Tanpa Kord
充电式LED手电筒



18V

- Metal hang hook swivels 360° and folds away for extra convenience

• Without Charger & Battery



Dimensions (L x W x H)

Dimensi 体积

380x79x116mm
(15"x9-11/16"x4-9/16")

Net Weight

Berat Bersih 净重

0.61 - 0.98kg (1.4 - 2.2lbs.)

Continuous Usage Time (approx.)

Masa Penggunaan Berterusan 连续使用时间

Full brightness: 20 hrs with BL1860B
Half brightness: 48 hrs with BL1860B

* All list price shown are for reference only (exclude SST).
* Semua harga yang ditunjukkan adalah untuk rujukan sahaja (tidak termasuk SST). 所有显示的建议零售价仅供参考 (不包括SST)。

Cordless
Tanpa Kord 无绳式

LED Flashlight
Lampu Suluh LED
LED 手电筒

Vacuum Cleaner
Penyedut Vakuum
吸尘器

Drilling / Fastening
Gasing / Pengikat
钻孔 / 紧固

Impact Drilling / Demolition
Gasing / Penorek
打桩机 / 凿墙机

Cutting
Pemotong
切割

Grinding / Sanding
Pengkilan / Pasiran
打磨 / 砂磨

Sawing
Gasing
锯切

Planing / Routing
Pegolan / Tumpang
刨削 / 榫嵌

Others
Lain-lain
其他

Outdoor Power Equipment
Alatan Kerja Luar
户外动力工具

Makita
Makita



Cordless
Tanpa Kord / 充電式

LED Flashlight
Lampu Suluh LED
LED 手電筒

Vacuum Cleaner
Pembersih Vakuum
吸尘器

Drilling / Fastening
Gores / Pengikat
钻孔 / 紧固

Impact Drilling / Demolition
Gores / Penembak
冲击钻孔 / 拆除加工

Cutting
Pemotong
切割

Grinding / Sanding
Pengkil / Mengkil
打磨 / 磨光

Sawing
Gergaji
锯切

Planing / Routing
Pengaliran / Rongga
刨削 / 雕刻

Others
Lain-lain
其他

Outdoor Power Equipment
Alat-alat Kerja Luar
園林-戶外

DML186 (DEBDML186) 18V

Cordless LED Flashlight
Lampu Suluh LED Tanpa Kord
充电式LED手电筒

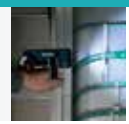

18V



- Hand strap for extra convenience

• Without Charger & Battery

Dimensions (L x W x H) Dimensi 体积	151x81x61mm (5-7/8"x3-3/16"x2-3/8")
Net Weight Berat Bersih 淨重	0.51 - 0.83kg (1.1 - 1.8lbs)
Continuous Usage Time (approx.) Masa Penggunaan Berterusan 连续使用时间	50 hrs with BL1830B

ML103 (AUAML103) 12Vmax

Cordless LED Flashlight
Lampu Suluh LED Tanpa Kord
充电式LED灯

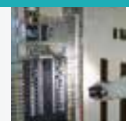

12Vmax



- 1.5W white single diffusion LED provides bright and wide illumination

• Without Charger & Battery

Dimensions (L x W x H) Dimensi 体积	77x54x28mm (3x2-1/8x1-1/8")
Net Weight Berat Bersih 淨重	0.27 - 0.43kg (0.6 - 1.0lbs)
Continuous Usage Time (approx.) Masa Penggunaan Berterusan 连续使用时间	14 hrs with BL1021B

ML101 (STEXML101) 10.8V

Rechargeable Grab Light
Lampu Suluh LED Tanpa Kord
充电式LED工作灯



10.8V



- Can be positioned at various places and angles with flexible legs

• Without Charger & Battery

Dimensions (L x W x H) Dimensi 体积	119x52x55mm (4-11/16x2-1/16x2-3/16")
Net Weight Berat Bersih 淨重	0.32kg (0.7lbs.)
Continuous Usage Time (approx.) Masa Penggunaan Berterusan 连续使用时间	9 hrs with BL1013



* All list price shown are for reference only (exclude SST).
* Semua harga yang ditunjukkan adalah untuk rujukan sahaja (tidak termasuk SST). 所有显示的建议零售价仅供参考 (不包括SST)。

Product Comparison List

	DML813 18V	DML814 18V	DML810 18V AC	ML003G 40Vmax 18V	DML809 18V AC	DML811 18V AC	DML805 18V AC
Run Time (hrs)	Up to: 3 Hi: with BL1850B Up to: 10 Lo: with BL1850B	Up to: 3 Hi: with BL1850B Up to: 10 Lo: with BL1850B	Up to: 15 with BL1850B x2	Up to: 10 Hi: with BL4040 Up to: 22 Lo: with BL4040	Up to: 8.5 Lo: with BL1860B x2	Up to: 13 Lo: with BL1860B	Up to: 8.5 Hi: with BL1850B Up to: 17 Lo: with BL1850B
Illuminance	Hi: 1,250lx, Lo: 400lx at 1m from the light Hi: 130lx, Lo: 40lx at 3m from the light Hi: 50lx, Lo: 15lx at 5m from the light	Hi: 1,250lx, Lo: 400lx at 1m from the light Hi: 130lx, Lo: 40lx at 3m from the light Hi: 50lx, Lo: 15lx at 5m from the light	550lx 300lx 150lx at 1m from the light	Hi: 500lx Lo: 200lx at 1m from the light	Hi: 3,800lx, Lo: 800lx at 1m from the light Hi: 380lx, Lo: 80lx at 3m from the light Hi: 150lx, Lo: 30lx at 5m from the light	Hi: 1,800lx, Lo: 350lx at 1m from the light Hi: 200lx, Lo: 40lx at 3m from the light Hi: 85lx, Lo: 17lx at 5m from the light	Hi: 1,150lx, Lo: 750lx at 0.5m from the light Hi: 300lx, Lo: 200lx at 1m from the light
Luminous Flux (lm=lumens)	High: 3,000lm Med: 1,700lm Low: 900lm	High: 3,000lm Med: 1,700lm Low: 900lm	High: 5,500lm Med: 3,000lm Low: 1,500lm	High: 1,100lm Low: 450lm	High: 10,000lm Med: 4,000lm Low: 2,000lm	High: 3,000lm Med: 1,500lm Low: 750lm	Hi: 750lm Lo: 450lm
Net Weight	7.2 - 7.9kg (15.9 - 17.4lbs.)	7.4 - 8.1kg (16.3 - 17.9lbs.)	13.9 - 15.3kg (30.6 - 33.7lbs)	3.7 - 4.7kg (8.2 - 10.4lbs)	5.7 - 7.0kg (12.6 - 15.4lbs)	4.1 - 4.8kg (9.0 - 10.5lbs)	2.3 - 2.7kg (5.1 - 5.9lbs)

	ML007G 40Vmax	DML812 18V	ML001G 40Vmax	DML815 18V	DML808 18V	ML106 12Vmax	ML105 12Vmax	ML002G 40Vmax
Run Time (hrs)	Up to: 10 Spot / Flood / Strobe: with BL4040 Up to: 7.5 Spot-Flood: with BL4040	Up to: 8 with BL1850B	Up to: 55 with BL4040	Up to: 54 with BL1860B	Up to: 26 with BL1850B	Up to: 12 with BL1041B	Up to: 14 with BL1041B	Up to: 51 with BL4040
Illuminance	Spot: 82,000lx Flood: 520lx Spot-Flood: 60,000lx	71,000lx 51,000lx 520lx at 1m from the light	3,000lx at 1m from the light	3,000lx at 1m from the light	170 - 4,500lx at 1m from the light	170 - 4,500lx at 1m from the light	5,500lx at 1m from the light	Main light (Full): 340lx Main light (Half): 310lx Sub light (On Top): 1,900lx at 1m from the light
Luminous Flux (lm=lumens)	Spot: 600lm Flood: 1,000lm Spot-Flood: 1,250lm	Spot: 600lm Spot/ Flood: 1,250lm Flood: 1,000lm	160lm	160lm	190lm	190lm	190lm	Main light (Full): 710lm Main light (1/4): 340lm Sub light (On Top): 130lm
Net Weight	1.6 - 2.9kg (3.5 - 6.4lbs)	1.7kg (3.8lbs)	1.0 - 1.3kg (2.2 - 2.9lbs)	0.26 - 0.93kg (0.57 - 2.05lbs)	0.73 - 1.09kg (1.6 - 2.4lbs)	0.61 - 0.78kg (1.3 - 1.7lbs)	0.53 - 0.70kg (1.2 - 1.5lbs)	1.2 - 1.5kg (2.7 - 3.3lbs)

	DML807 18V	ML104 12Vmax	ML006G 40Vmax	DML816 18V	DML801 18V	DML186 18V	ML103 12Vmax	ML101 10.8V
Run Time (hrs)	Up to: 23 Main light (1/2) with BL1850B Up to: 36 Sub light with BL1850B	Up to: 17 Main light (1/2) with BL1041B Up to: 19 Sub light with BL1041B	Up to: 20 Hi: with BL4040 Up to: 82 Lo: with BL4040	Up to: 17 Hi: with BL1860B Up to: 75 Lo: with BL1860B	Up to: 20 Full: with BL1860B Up to: 48 Half: with BL1860B	Up to: 50 with BL1830B	Up to: 28 with BL1041B	Up to: 9 with BL1013
Illuminance	Main light (Full): 340lx Main light (1/2): 310lx Sub light (On Top): 1,900lx at 0.5m from the light	Main light (Full): 340lx Main light (1/4): 190lx Sub light (On Top): 1,900lx at 0.5m from the light	Hi: 800lx Med: 400lx Lo: 180lx at 0.5m from the light	Hi: 800lx Med: 400lx Lo: 180lx at 0.5m from the light	Full: 400lx Half: 200lx at 0.5m from the light	500lx at 1m from the light	240lx at 0.5m from the light 50lx at 1m from the light	400lx at 1m from the light
Luminous Flux (lm=lumens)	Main light (Full): 710lm Main light (1/2): 340lm Sub light (On Top): 130lm	Main light (Full): 710lm Main light (1/4): 190lm Sub light (On Top): 130lm	High: 500lm Med: 250lm Low: 100lm	High: 500lm Med: 250lm Low: 100lm	Full: 240lm Half: 120lm	-	100lm	-
Net Weight	0.72 - 1.1kg (1.6 - 2.4lbs)	0.61 - 0.78kg (1.4 - 1.7lbs)	1.1 - 1.7kg (2.4 - 3.8lbs)	0.7 - 1.1kg (1.5 - 2.4lbs)	0.61 - 0.98kg (1.4 - 2.2lbs)	0.51 - 0.83kg (1.1 - 1.8lbs)	0.27 - 0.43kg (0.6 - 1.0lbs)	0.32kg (0.7lbs.)

* All list price shown are for reference only (exclude SST).

* Semua harga yang ditunjukkan adalah untuk rujukan sahaja (tidak termasuk SST). 所有显示的建议零售价仅供参考 (不包括SST)。

Cordless
Tetapan Kord 30.0kV

LED Flashlight
Lampu Suhu LED
LED383838

Vacuum Cleaner
Pembersih Vakuum
真空吸尘器

Drilling / Fastening
Gergasi / Pengikat
电钻 / 紧固件

Impact Drilling / Demolition
Gergasi / Penanggal
电钻 / 电锤

Cutting
Pemotong
切割机

Grinding / Sanding
Pengkilan / Pasiran
砂轮机 / 砂纸

Sawing
Gergaji
电锯

Planing / Routing
Polycutan / Tunggam
刨床 / 铣床

Others
Lain-lain
其他

Outdoor Power Equipment
Alatan Korpul Luar
户外动力工具

Makita
MAKITA

Cordless
Tangkai Tanpa Kabel

LED Flashlight
Lampu Sinar LED
LED 燈筒

Vacuum Cleaner
Penarik Debu Vakum
吸尘器

Drilling / Fastening
Dremel / Pengikat
钻机 / 螺絲

Impact Drilling / Demolition
Dremel / Pencah
起工钻机 / 拆牆加工

Cutting
Pemotong
切割机

Grinding / Sanding
Pengkilan / Poles
研磨 / 砂磨

















Sawing
Gergaji
锯切

Planing / Routing
Pengilam / Tenggam
刨削 / 磨削

Others
Lain-lain
其他

Outdoor Power Equipment
Alatan Kuasa Luar
園林工具

Makita
MAKITA

Capacity	DRY Kering 干	WET Basah 湿
15L Dry 12L Wet	<p>DVC155L Suction Power 105W</p> 	<p>DVC152L Suction Power 90W</p> 
		<p>DVC150L HYBRID Suction Power 320W (AC) 25-70W (DC)</p> 
15L	<p>DVC157L Suction Power 110W HEPA Filter</p> 	<p>DVC154L Suction Power 65W HEPA Filter</p> 
	<p>DVC153L Suction Power 90W HEPA Filter</p> 	<p>DVC151L HYBRID Suction Power 320W (AC) 25-70W (DC) HEPA Filter</p> 
8L Dry 6L Wet	<p>DVC865L Suction Power 105W</p> 	<p>DVC862L Suction Power 65W</p> 
		<p>DVC860L HYBRID Suction Power 320W (AC) 25-70W (DC)</p> 
		<p>VC001GL Suction Power 310W</p> 
8L	<p>DVC864L Suction Power 65W HEPA Filter</p> 	<p>DVC867L Suction Power 110W HEPA Filter</p> 
	<p>DVC863L Suction Power 90W HEPA Filter</p> 	<p>VC005GL Suction Power 265W</p> 
	<p>VC002GL Suction Power 205W HEPA Filter</p> 	

Model	Powered	Max Air Flow (m ³ /min)	Max Sealed Suction (kPa)	BL MOTOR	XPT	AWS
VC005GL	40Vmax	2.8	23	●	●	—
VC002GL	40Vmax	1.8	23	●	●	●
VC001GL	40Vmax	3.2	23	●	●	—
DVC867L	18Vx2	2.1	11	●	●	●
DVC865L	18Vx2	2.1	11	●	●	—
DVC864L	18Vx2	2.1	9.8	●	●	●
DVC863L	18Vx2	2.1	9.8	●	●	—
DVC862L	18Vx2	2.1	9.8	●	●	—
DVC860L	18Vx2 AC	DC: 2.1** AC: 3.6**	DC: 9.0 AC: 24	—	—	—
DVC157L	18Vx2	2.1	11	●	●	●
DVC155L	18Vx2	2.1	11	●	●	—
DVC154L	18Vx2	2.1	9.8	●	●	●
DVC153L	18Vx2	2.1	9.8	●	●	—
DVC152L	18Vx2	2.1	9.8	●	●	—
DVC151L	18Vx2 AC	DC: 2.1** AC: 3.6**	DC: 9.0 AC: 24	—	—	—
DVC150L	18Vx2 AC	DC: 2.1** AC: 3.6**	DC: 9.0 AC: 24	—	—	—

* All list price shown are for reference only (exclude SST).

* Semua harga yang ditunjukkan adalah untuk rujukan sahaja (tidak termasuk SST). 所有显示的建议零售价仅供参考 (不包括SST)。

**with hose Ø 38-2.5



*Compatible batteries

Cordless Vacuum Cleaner

Continuous Usage Time with BL4050F (Dial Mode 1)

220min
(approx.)

AWS Auto-start Wireless System VC002GL

The wireless activation function enables clean and comfortable operation. By connecting a supported tool to the cleaner, you can run the cleaner automatically along with the switch operation of the tool.

Bluetooth

WUT01 (Optional) wireless unit
Part No. 1.99393-1

Enables wireless connection of Makita AWS™ capable tools with AWS™ Vacuum Cleaners



VC001GL
For Cleaning Wet & Dry



VC002GL
For Dust Collecting Airborne particles



VC005GL
For Cleaning Dry (for building maintenance industry)

VC001GLZ

Cordless Vacuum Cleaner (Wet & Dry)

Pembersih Vakum Tanpa Kord (Basah dan Kering)
充电式吸尘器(干湿两用)

• The same high power as corded vacuum cleaners

Standard Equipment: Nozzle Assembly Set (191G86-8), Long Sash Nozzle (198919-6), Telescopic Pipe (140G19-0), Hose Complete 32-1.7 Set (199493-7), Poly Bag Set (10pcs/ pack) (195432-5), Multi Hook

• GLZ: Without Charger & Battery



*Recommended batteries 4.0Ah, 5.0Ah



Capacity Kapasiti 尘袋容量	Dust: 8L Water: 6L
Max Air Flow Aliran Udara 最大空气流量	3.2m³/min
Max Sealed Suction Sedutan Terkedap 最大密封吸力	23kPa
Suction Power Kuasa Sedutan 吸力	310W
Dimensions (L x W x H) Dimensi 体积	366x334x425mm (14-3/8x13-1/8x16-3/4")
Net Weight Berat Bersih 净重	8.1 - 11.2kg (17.9 - 24.7lbs.)
Continuous Usage Time (approx.) Masa Penggunaan Berterusan 连续使用时间	220 min with BL4050F Dial Mode 1

VC005GLZ

Cordless Vacuum Cleaner (Dry)

Pembersih Vakum Tanpa Kord (Kering)
充电式吸尘器(干用)

• The same high power as corded vacuum cleaners
• Airborne particles

Standard Equipment: Nozzle Assembly Set (191G86-8), Long Sash Nozzle (198919-6), Telescopic Pipe (140G19-0), Hose Complete 32-1.7 Set (199493-7), Poly Bag Set (10pcs/ pack) (195432-5), Multi Hook

• GLZ: Without Charger & Battery



*Recommended batteries 4.0Ah, 5.0Ah



Capacity Kapasiti 尘袋容量	Dust: 8L
Max Air Flow Aliran Udara 最大空气流量	2.8m³/min
Max Sealed Suction Sedutan Terkedap 最大密封吸力	23kPa
Suction Power Kuasa Sedutan 吸力	265W
Dimensions (L x W x H) Dimensi 体积	366x334x397mm (14-3/8x13-1/8x15-5/8")
Net Weight Berat Bersih 净重	7.9 - 11.0kg (17.4 - 24.3lbs.)
Continuous Usage Time (approx.) Masa Penggunaan Berterusan 连续使用时间	220 min with BL4050F Dial Mode 1

VC002GLZ

Cordless Vacuum Cleaner (Dry)

Pembersih Vakum Tanpa Kord (Kering)
充电式吸尘器(干用)

• Variable suction power control dial (stepless) allows for a wide range of applications from "High power" to "Quiet" cleaning
• Dry (for building maintenance industry)

Standard Equipment: Nozzle Assembly Set, Corner Nozzle (410306-2), Straight Pipe (192563-1), Bending Pipe (192562-3), Hose Complete 28-3.5 Set (195433-3), Hose Complete 38-2.5 Set (195434-1), Front Cuff 24 (195546-0), Front Cuff 22 (195547-8), Poly Bag Set (10pcs/ pack) (195432-5), Multi Hook

• GLZ: Without Charger & Battery



*Recommended batteries 4.0Ah, 5.0Ah



Capacity Kapasiti 尘袋容量	Dust: 8L
Max Air Flow Aliran Udara 最大空气流量	1.8m³/min
Max Sealed Suction Sedutan Terkedap 最大密封吸力	23kPa
Suction Power Kuasa Sedutan 吸力	205W
Dimensions (L x W x H) Dimensi 体积	366x334x425mm (14-3/8x13-1/8x16-3/4")
Net Weight Berat Bersih 净重	8.3 - 11.4kg (18.3 - 25.1lbs.)
Continuous Usage Time (approx.) Masa Penggunaan Berterusan 连续使用时间	220 min with BL4050F Dial Mode 1

* All list price shown are for reference only (exclude SST).

* Semua harga yang ditunjukkan adalah untuk rujukan sahaja (tidak termasuk SST). 所有显示的建议零售价仅供参考 (不包括SST)。

Cordless
Tanpa Kord 无线

LED Flashlight
Lampu Sash LED
LED照明灯

Vacuum Cleaner
Pembersih Vakum
吸尘器

Drilling / Fastening
Gergaji / Pengikat
电钻 / 螺帽

Impact Drilling / Demolition
Gergaji / Pemecah
电钻 / 电锤

Cutting
Pemotong
切割机

Grinding / Sanding
Pengkilan / Palsan
打磨 / 砂磨

Sawing
Gergaji
电锯

Planing / Routing
Pengkilan / Tonggolan
刨平 / 压边

Others
Lain-lain
其他

Outdoor Power Equipment
Alatan Keras Luar
户外动力工具





Li-ion Ah 6.0 5.0 4.0 3.0 2.0 1.5

DVC150LZ

Cordless & Cordless Vacuum Cleaner (Wet & Dry)

Pembersih Vakum Kuasa Elektrik Dan Tanpa Kord (Basah dan Kering)
 充电式 + 电源驱动吸尘器 (干湿两用)



- For both wet and dry vacuum cleaning

Standard Equipment: Floor Nozzle, Corner Nozzle, Straight Pipe, Bent Pipe, Hose (38mm), Plastic Dust Bag, Plastic Dust Bag x10, Cloth Filter, Tool Box, Connection Cord

- LZ: Without Charger & Battery



Capacity Kapasiti 尘袋容量	Dust: 15L Water: 12L
Max Air Flow Aliran Udara 最大空气流量	AC: 3.6m³/min DC: 2.1m³/min
Max Sealed Suction Sedutan Terkedap 最大密封吸力	AC: 24kPa DC: 9kPa
Suction Power Kuasa Sedutan 吸力	AC: 320W DC: 25 - 70W
Dimensions (L x W x H) Dimensi 体积	366x334x421mm (14-3/8"x13-1/8"x16-1/2")
Net Weight Berat Bersih 净重	8.9 - 9.6kg (19.7 - 21.1lbs.)
Continuous Usage Time (approx.) Masa Penggunaan Berterusan 连续使用时间	40 min with BL1850B x2 (Speed Dial 5)

DVC151LZ

Cordless and Cordless Vacuum Cleaner (Dry)

Pembersih Vakum Kuasa Elektrik Dan Tanpa Kord (Kering)
 充电式 + 电源驱动吸尘器 (干用)



- 15L Large dust bag capacity

Standard Equipment: Floor Nozzle, Corner Nozzle, Straight Pipe, Bent Pipe, Hose (38mm), Hose (28mm), Front Cuffs (22, 24, 28), Plastic Dust Bag, Plastic Dust Bag x10, Cloth Filter, Damper, Dry Powder Filter, Tool Box, Connection Cord

- LZ: Without Charger & Battery



Capacity Kapasiti 尘袋容量	Dust: 15L
Max Air Flow Aliran Udara 最大空气流量	AC: 3.6m³/min DC: 2.1m³/min
Max Sealed Suction Sedutan Terkedap 最大密封吸力	AC: 24kPa DC: 9kPa
Suction Power Kuasa Sedutan 吸力	AC: 320W DC: 25 - 70W
Dimensions (L x W x H) Dimensi 体积	366x334x421mm (14-3/8"x13-1/8"x16-1/2")
Net Weight Berat Bersih 净重	9.6 - 10.3kg (21.2 - 22.6lbs.)
Continuous Usage Time (approx.) Masa Penggunaan Berterusan 连续使用时间	65 min with BL1850B x2

DVC152LZ

Cordless Vacuum Cleaner (Wet & Dry)

Pembersih Vakum Tanpa Kord (Basah dan Kering)
 充电式吸尘器 (干湿两用)



- For both wet and dry vacuum cleaning

Standard Equipment: Floor Nozzle, Corner Nozzle, Straight Pipe, Bent Pipe, Hose (38mm), Plastic Dust Bag, Plastic Dust Bag x10, Cloth Filter, Tool Box

- LZ: Without Charger & Battery



Capacity Kapasiti 尘袋容量	Dust: 15L Water: 12L
Max Air Flow Aliran Udara 最大空气流量	2.1m³/min
Max Sealed Suction Sedutan Terkedap 最大密封吸力	9.8kPa
Suction Power Kuasa Sedutan 吸力	90W
Dimensions (L x W x H) Dimensi 体积	366x334x421mm (14-3/8"x13-1/8"x16-1/2")
Net Weight Berat Bersih 净重	7.3 - 7.9kg (16.0 - 17.4lbs.)
Continuous Usage Time (approx.) Masa Penggunaan Berterusan 连续使用时间	40 min with BL1850B x2

DVC153LZ

Cordless Vacuum Cleaner (Dry)

Pembersih Vakum Tanpa Kord (Kering)
 充电式吸尘器 (干用)



- 15L Large dust bag capacity

Standard Equipment: Floor Nozzle, Corner Nozzle, Straight Pipe, Bent Pipe, Hose (38mm), Hose (28mm), Front Cuffs (22, 24, 28), Plastic Dust Bag, Plastic Dust Bag x10, Cloth Filter, Damper, Dry Powder Filter

- LZ: Without Charger & Battery



Capacity Kapasiti 尘袋容量	Dust: 15L
Max Air Flow Aliran Udara 最大空气流量	2.1m³/min
Max Sealed Suction Sedutan Terkedap 最大密封吸力	9.8kPa
Suction Power Kuasa Sedutan 吸力	90W
Dimensions (L x W x H) Dimensi 体积	366x334x421mm (14-3/8"x13-1/8"x16-1/2")
Net Weight Berat Bersih 净重	8.0 - 8.6kg (17.6 - 19.0lbs.)
Continuous Usage Time (approx.) Masa Penggunaan Berterusan 连续使用时间	40 min with BL1850B x2

DVC154LZ | DVC154LZX

Cordless Vacuum Cleaner (Dry)

Pembersih Vakum Tanpa Kord (Kering)
 充电式吸尘器 (干用)



- Auto-Start Wireless System (AWS) Connects to Power Tool with Bluetooth

Standard Equipment: DVC154LZ: Floor Nozzle, Corner Nozzle, Straight Pipe, Bent Pipe, Hose (38mm-2.5m), Plastic Dust Bag, Plastic Dust Bag x10, Cloth Filter, Front Cuffs, Dry Powder Filter, Damper, Wireless Unit (Build-in)
 DVC154LZX: Hose (38mm-2.5m), Plastic Dust Bag, Plastic Dust Bag x10, Cloth Filter, Front Cuffs, Dry Powder Filter, Damper, Wireless Unit (Build-in)

- LZ / LZX: Without Charger & Battery

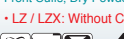

Capacity Kapasiti 尘袋容量	Dust: 15L
Max Air Flow Aliran Udara 最大空气流量	2.1m³/min
Max Sealed Suction Sedutan Terkedap 最大密封吸力	9.8kPa
Suction Power Kuasa Sedutan 吸力	65W
Dimensions (L x W x H) Dimensi 体积	366x334x421mm (14-3/8"x13-1/8"x16-1/2")
Net Weight Berat Bersih 净重	8.0 - 8.6kg (17.6 - 19.0lbs.)
Continuous Usage Time (approx.) Masa Penggunaan Berterusan 连续使用时间	40 min with BL1850B x2

* All list price shown are for reference only (exclude SST).

* Semua harga yang ditunjukkan adalah untuk rujukan sahaja (tidak termasuk SST). 所有显示的建议零售价仅供参考 (不包括SST)。

Cordless
Tanggap Kord / 无线式

LED Flashlight
Lampu Suka LED
LED照明灯

Vacuum Cleaner
Pembersih Vakum
吸尘器

Drilling | Fastening
Ganjal / Pasang
钻孔 / 紧固

Impact Drilling | Demolition
Ganjal / Pencah
钻孔 / 拆除

Cutting
Pemotong
切割

Grinding | Sanding
Pengam / Pasir
打磨 / 砂磨

Sawing
Gergaji
锯切

Planing | Routing
Pengam / Tengam
刨削 / 雕刻

Others
Lain-lain
其他

Outdoor Power Equipment
Alatan Kuasa Luar
户外动力设备

Makita
Makita



Li-ion Ah 6.0 5.0 4.0 3.0 2.0 1.5

DVC155LZX3

Cordless Vacuum Cleaner (Wet & Dry)
Pembersih Vakum Tanpa Kord (Basah dan Kering)
充电式吸尘器(干湿两用)



- More Powerful Suction Power

Standard Equipment: Floor Nozzle, Long Sash Nozzle, Telescopic Pipe Assembly, Bent Pipe, Pipe, Hose, Plastic Dust Bag x10, Filter, Tool Box, Plastic Dust Bag

- LZX3: Without Charger & Battery



Capacity Kapasiti 尘袋容量	Dust: 15L Water: 12L
Max Air Flow Aliran Udara 最大空气流量	2.1m³/min
Max Sealed Suction Sedutan Terkedap 最大密封吸力	11kPa
Suction Power Kuasa Sedutan 吸力	105W
Dimensions (L x W x H) Dimensi 体积	366x334x421mm (14-3/8"x13-1/8"x16-1/2")
Net Weight Berat Bersih 净重	7.2 - 7.9kg (15.9 - 17.4lbs.)
Continuous Usage Time (approx.) Masa Penggunaan Berterusan 连续使用时间	83 min with BL1850B x2

DVC157LZX5

Cordless Vacuum Cleaner (Dry)
Pembersih Vakum Tanpa Kord (Kering)
充电式吸尘器(干用)



- Auto-start Wireless System (AWS) connects to power tool with Bluetooth

Standard Equipment: Floor Nozzle, Corner Nozzle, Straight Pipe, Bent Pipe, Hose (38mm-2.5m), Plastic Dust Bag, Plastic Dust Bag x10, Cloth Filter, Tool Box, Damper, Dry Powder Filter

- LZX5: Without Charger & Battery



Capacity Kapasiti 尘袋容量	Dust: 15L
Max Air Flow Aliran Udara 最大空气流量	2.4m³/min
Max Sealed Suction Sedutan Terkedap 最大密封吸力	11kPa
Suction Power Kuasa Sedutan 吸力	110W
Dimensions (L x W x H) Dimensi 体积	366x334x421mm (14-3/8"x13-1/8"x16-1/2")
Net Weight Berat Bersih 净重	8.0 - 8.6kg (17.6 - 19.0lbs.)
Continuous Usage Time (approx.) Masa Penggunaan Berterusan 连续使用时间	83 min with BL1850B x2

DVC860LZ

Cordless & Corded Vacuum Cleaner (Wet & Dry)
Pembersih Vakum Kuasa Elektrik Dan Tanpa Kord (Basah dan Kering)
充电式 + 电源驱动吸尘器(干湿两用)



- Cloth filter type: for both wet & dry vacuum cleaning

Standard Equipment: Floor Nozzle, Corner Nozzle, Straight Pipe, Bent Pipe, Hose (38mm), Plastic Dust Bag, Plastic Dust Bag x10, Cloth Filter, Tool Box, Connection Cord

- LZ: Without Charger & Battery



Capacity Kapasiti 尘袋容量	Dust: 8L Water: 6L
Max Air Flow Aliran Udara 最大空气流量	AC: 3.6m³/min DC: 2.1m³/min
Max Sealed Suction Sedutan Terkedap 最大密封吸力	AC: 24kPa DC: 9kPa
Suction Power Kuasa Sedutan 吸力	AC: 320W DC: 25 - 70W
Dimensions (L x W x H) Dimensi 体积	366x334x368mm (14-3/8"x13-1/8"x14-1/2")
Net Weight Berat Bersih 净重	8.6kg (19.0lbs.)
Continuous Usage Time (approx.) Masa Penggunaan Berterusan 连续使用时间	65 min with BL1850B x2

DVC862LPT2 | DVC862LRT2 | DVC862LZ

Cordless Vacuum Cleaner (Wet & Dry)
Pembersih Vakum Tanpa Kord (Basah dan Kering)
充电式吸尘器(干湿两用)

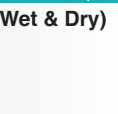

- For both wet and dry vacuum cleaning

Standard Equipment: Floor Nozzle, Corner Nozzle, Straight Pipe, Bent Pipe, Hose (38mm), Plastic Dust Bag, Plastic Dust Bag x10, Cloth Filter, Tool Box

- LPT2: 1x Two Port Multi Fast Charger, 2x 5.0Ah Battery
- LRT2: 1x Rapid Charger, 2x 5.0Ah Battery
- LZ: Without Charger & Battery



Capacity Kapasiti 尘袋容量	Dust: 8L Water: 6L
Max Air Flow Aliran Udara 最大空气流量	2.1m³/min
Max Sealed Suction Sedutan Terkedap 最大密封吸力	9.8kPa
Suction Power Kuasa Sedutan 吸力	90W
Dimensions (L x W x H) Dimensi 体积	366x334x368mm (14-3/8"x13-1/8"x14-1/2")
Net Weight Berat Bersih 净重	7.0kg (15.5lbs.)
Continuous Usage Time (approx.) Masa Penggunaan Berterusan 连续使用时间	40 min with BL1850B x2

DVC863LPT2 | DVC863LRT2 | DVC863LZ

Cordless Vacuum Cleaner (Dry)
Pembersih Vakum Tanpa Kord (Kering)
充电式吸尘器(干用)

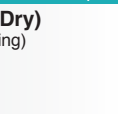

- 8L Large dust bag capacity enables continuous cleaning work

Standard Equipment: Floor Nozzle, Corner Nozzle, Straight Pipe, Bent Pipe, Hose 38mm, Hose 28mm, Front Cuffs (22, 24, 38), Plastic Dust Bag, Plastic Dust Bag x10, Cloth Filter, Tool Box

- LPT2: 1x Two Port Multi Fast Charger, 2x 5.0Ah Battery
- LRT2: 1x Rapid Charger, 2x 5.0Ah Battery
- LZ: Without Charger & Battery



Capacity Kapasiti 尘袋容量	Dust: 8L
Max Air Flow Aliran Udara 最大空气流量	2.1m³/min
Max Sealed Suction Sedutan Terkedap 最大密封吸力	9.8kPa
Suction Power Kuasa Sedutan 吸力	90W
Dimensions (L x W x H) Dimensi 体积	366x334x368mm (14-3/8"x13-1/8"x14-1/2")
Net Weight Berat Bersih 净重	7.7kg (17.1lbs.)
Continuous Usage Time (approx.) Masa Penggunaan Berterusan 连续使用时间	40 min with BL1850B x2

* All list price shown are for reference only (exclude SST).

* Semua harga yang ditunjukkan adalah untuk rujukan sahaja (tidak termasuk SST). 所有显示的建议零售价仅供参考 (不包括SST)。

Cordless
Tanpa Kord 无线式

LED Flashlight
Lampu Suhu LED
LED照明灯

Vacuum Cleaner
Pembersih Vakum
吸尘器

Drilling / Fastening
Cetus / Pengikat
钻孔 / 固定

Impact Drilling / Demolition
Gerudi / Rombak
冲击钻孔 / 拆除施工

Cutting
Pemotongan
切割

Grinding / Sanding
Pengkilan / Pasukan
打磨 / 砂磨

Sawing
Gergaji
锯切

Planing / Routing
Pengkilan / Tunggam
刨削 / 雕花

Others
Lain-lain
其他

Outdoor Power Equipment
Alatan Kerja Luar
园林机具





Li-ion Ah 6.0 5.0 4.0 3.0 2.0 1.5

Cordless
Tanpa Kord / 無線

LED Flashlight
Lampu Senter LED
LED 手電筒

Vacuum Cleaner
Pembersih Vakum
吸尘器

Drilling / Fastening
Ganjal / Pengencat
钻头 / 螺絲

Impact Drilling / Demolition
Ganjal / Perusak
打洞 / 拆牆

Cutting
Pemotong
切機

Grinding / Sanding
Pengam / Pasir
打磨 / 砂磨

Sawing
Gergaji
電鋸

Planing / Routing
Pengam / Pengalir
刨 / 磨

Others
Lain-lain
其他

Outdoor Power Equipment
Alat-alat Kuasa Luar
園林工具



DVC864LZ

Cordless Vacuum Cleaner (Dry)
Pembersih Vakum Tanpa Kord (Kering)
充电式吸尘器(干用)



- Auto-Start Wireless System (AWS) Connects to Power Tool with Bluetooth

Standard Equipment: Floor Nozzle, Corner Nozzle, Straight Pipe, Bent Pipe, Hose (38mm), Hose (28mm), Front Cuffs (22, 24, 28), Plastic Dust Bag, Plastic Dust Bag x10, Cloth Filter, Tool Box, Wireless Unit (Build-in)

- LZ: Without Charger & Battery



Capacity Kapasiti 尘袋容量	Dust: 8L
Max Air Flow Aliran Udara 最大空气流量	2.1m³/min
Max Sealed Suction Sedutan Terkedad 最大密封吸力	9.8kPa
Suction Power Kuasa Sedutan 吸力	65W
Dimensions (L x W x H) Dimensi 体积	366x334x368 mm (14-3/8"x13-1/8"x14-1/2")
Net Weight Berat Bersih 淨重	7.7 - 8.4 kg (17.1 - 18.4 lbs.)
Continuous Usage Time (approx.) Masa Penggunaan Berterusan 连续使用时间	40 min with BL1850B x2

DVC865LZX3

Cordless Vacuum Cleaner (Wet & Dry)
Pembersih Vakum Tanpa Kord (Basah dan Kering)
充电式吸尘器(干湿两用)



- For both wet and dry vacuum cleaning

Standard Equipment: Floor Nozzle, Long Sash Nozzle, Telescopic Pipe Assembly, Bent Pipe, Pipe, Hose, Plastic Dust Bag x10, Filter, Tool Box

- LZX3: Without Charger & Battery



Capacity Kapasiti 尘袋容量	Dust: 8L Water: 6L
Max Air Flow Aliran Udara 最大空气流量	2.1m³/min
Max Sealed Suction Sedutan Terkedad 最大密封吸力	11kPa
Suction Power Kuasa Sedutan 吸力	105W
Dimensions (L x W x H) Dimensi 体积	366x334x368mm (14-3/8"x13-1/8"x14-1/2")
Net Weight Berat Bersih 淨重	7.0 - 7.7kg (15.4 - 17.0lbs.)
Continuous Usage Time (approx.) Masa Penggunaan Berterusan 连续使用时间	83 min with BL1850B x2 Dial Mode 1

DVC867LZX1

Cordless Vacuum Cleaner (Dry)
Pembersih Vakum Tanpa Kord (Kering)
充电式吸尘器(干用)



- Auto-start Wireless System (AWS) connects to power tool with Bluetooth

Standard Equipment: Floor Nozzle, Corner Nozzle, Straight Pipe, Bent Pipe, Hose (38mm-2.5m), Plastic Dust Bag, Plastic Dust Bag x10 (195432-5), Cloth Filter, Tool Box

- LZX1: Without Charger & Battery



Capacity Kapasiti 尘袋容量	Dust: 8L
Max Air Flow Aliran Udara 最大空气流量	2.4m³/min
Max Sealed Suction Sedutan Terkedad 最大密封吸力	11kPa
Suction Power Kuasa Sedutan 吸力	110W
Dimensions (L x W x H) Dimensi 体积	366x334x368mm (14-3/8"x13-1/8"x14-1/2")
Net Weight Berat Bersih 淨重	7.7 - 8.4kg (17.0 - 18.5lbs.)
Continuous Usage Time (approx.) Masa Penggunaan Berterusan 连续使用时间	83 min with BL1850B x2 Dial Mode 1

DVC660Z

Cordless Backpack Vacuum Cleaner
Pembersih Vakum Beg Galas Tanpa Kord
充电式背负吸尘器



- Increased suction power for improved dust collection

Standard Equipment: Floor Nozzle, Hose, Hose Band, Nozzle Assembly, Telescopic Pipe Assembly, Bent Pipe, Free Nozzle, Dust Bag

- Z: Without Charger & Battery



Capacity Kapasiti 尘袋容量	Paper Dust Bag: 6.0L Cloth Dust Bag: 5.5L
Max Air Flow Aliran Udara 最大空气流量	w/ Hose complete 32-1.0: 2.2m³/min w/ Hose Complete 28-1.0: 2.0m³/min
Max Sealed Suction Sedutan Terkedad 最大密封吸力	11kPa
Suction Power Kuasa Sedutan 吸力	Max: 90W High: 45W Normal: 25W With Hose 28-1.0
Dimensions (L x W x H) Dimensi 体积	297x174x523mm (11-3/4"x6-7/8"x20-5/8")
Net Weight Berat Bersih 淨重	6.1 - 6.7kg (13.4 - 14.8lbs.)
Continuous Usage Time (approx.) Masa Penggunaan Berterusan 连续使用时间	Max: 33 min High: 62 min Normal: 116 min with BL1850B x2

DVC665Z

Cordless Backpack Vacuum Cleaner
Pembersih Vakum Beg Galas Tanpa Kord
充电式背负吸尘器



- Increased suction power for improved dust collection

Standard Equipment: Hose Band, Filter Bag, Hose 28-1.5, Front Cuffs (22, 24)

- Z: Without Charger & Battery



Capacity Kapasiti 尘袋容量	Paper Dust Bag: 6.0L Cloth Dust Bag: 5.5L
Max Air Flow Aliran Udara 最大空气流量	w/ Hose Complete 28-1.5: 1.8 m³/min
Max Sealed Suction Sedutan Terkedad 最大密封吸力	11kPa
Suction Power Kuasa Sedutan 吸力	High: 85W Normal: 45W With Hose 28-1.5
Dimensions (L x W x H) Dimensi 体积	297x174x523mm (11-3/4"x6-7/8"x20-5/8")
Net Weight Berat Bersih 淨重	6.1 - 6.7kg (13.5 - 14.9lbs.)
Continuous Usage Time (approx.) Masa Penggunaan Berterusan 连续使用时间	High: 33 min Normal: 62 min with BL1850B x2

* All list price shown are for reference only (exclude SST).

* Semua harga yang ditunjukkan adalah untuk rujukan sahaja (tidak termasuk SST). 所有显示的建议零售价仅供参考 (不包括SST)。



Li-ion Ah 6.0 | 5.0 | 4.0 | 3.0 | 2.0 | 1.5

DVC265ZX

Cordless Backpack Vacuum Cleaner

Pembersih Vakum Beg Galas Tanpa Kord
充电式背负吸尘器

- Increased suction power for improved dust collection



Standard Equipment: Hose, Hose Band, Dust Bag, Front Cuffs (22, 24)

• ZX: Without Charger & Battery



Capacity Kapasiti 尘袋容量	Paper Dust Bag: 2.0L Cloth Dust Bag: 1.5L
Max Air Flow Aliran Udara 最大空气流量	w/ Hose Complete 28-1.0: 2.0m ³ /min w/ Hose Complete 28-1.5: 1.8m ³ /min
Max Sealed Suction Sedutan Terkapat 最大密封吸力	11kPa
Suction Power Kuasa Sedutan 吸力	w/ Hose 28-1.0: High: 90W Normal: 45W w/ Hose 28-1.5: High: 85W Normal: 45W
Dimensions (L x W x H) Dimensi 体积	230x152x373mm (9"x6"x14-3/4")
Net Weight Berat Bersih 淨重	3.9 - 4.5kg (8.6 - 10.0lbs.)
Continuous Usage Time (approx.) Masa Penggunaan Berterusan 连续使用时间	High: 33 min Low: 62 min with BL1850B x2

DVC261Z

Cordless Backpack Vacuum Cleaner

Pembersih Vakum Beg Galas Tanpa Kord
充电式背负吸尘器

- Increased Suction Power for Improved Dust Collection



DVC261

Models and specs may vary by country

Standard Equipment: HEPA Filter Assembly, Hose Band, Paper Filter Bag (2L), Hose (28mm), Floor Nozzle, Flexible Rubber Nozzle, Telescopic Pipe Assembly, Bent Pipe

• Z: Without Charger & Battery



Capacity Kapasiti 容量	Paper Dust Bag: 2.0L Cloth Dust Bag: 1.5L
Max Air Flow Aliran Udara 最大空气流量	w/ Hose complete 38-1.5: 2.3 m ³ /min w/ Hose complete 32-1.0: 2.2 m ³ /min w/ Hose Complete 28-1.0: 2.0 m ³ /min w/ Hose Complete 28-1.5: 1.8 m ³ /min
Max Sealed Suction Sedutan Terkapat 最大密封吸力	11 kPa
Suction Power Kuasa Sedutan 吸力	Max/ High/ Normal w/ Hose 38-1.5: 105/ 55/ 30W Max/ High/ Normal w/ Hose 28-1.0: 90/ 45/ 25W Max/ High/ Normal w/ Hose 28-1.5: 85/ 45/ 25W
Dimensions (L x W x H) Dimensi 体积	230x152x373mm (9"x6"x14-3/4")
Net Weight Berat Bersih 淨重	3.8 - 4.5kg (8.5 - 9.9lbs.)
Continuous Usage Time (approx.) Masa Penggunaan Berterusan 连续使用时间	Normal: 140 min High: 75 min Max: 40 min with BL1860B x2

DVC260Z DVC260ZX

Cordless Backpack Vacuum Cleaner

Pembersih Vakum Beg Galas Tanpa Kord
充电式背负吸尘器

- Max suction power 45W



DVC260

Models and specs may vary by country

Standard Equipment: HEPA Filter Assembly, Backpack Shoulder Harness, Hose Band, Paper Filter Bag (2L), Hose 28mm (1.0M), Floor Nozzle, Flexible Rubber Nozzle, Telescopic Pipe Assembly, Bent Pipe

DVC260ZX: HEPA Filter Assembly, Backpack Shoulder Harness, Hose Band, Paper Filter Bag (2L), Hose 28mm (1.5M), Front Cuffs (22, 24)

• Z / ZX: Without Charger & Battery



Capacity Kapasiti 容量	Filter bag / Paper dust bag: 2.0L Cloth dust bag: 1.5L
Max Air Flow Aliran Udara 最大空气流量	1.5m ³ /min
Max Sealed Suction Sedutan Terkapat 最大密封吸力	7.1kPa (710mmH ₂ O)
Suction Power Kuasa Sedutan 吸力	High: 45W Low: 25W
Dimensions (L x W x H) Dimensi 体积	230x152x373mm (9"x6"x14-3/4")
Net Weight Berat Bersih 淨重	3.8kg (8.5 lbs)
Continuous Usage Time (approx.) Masa Penggunaan Berterusan 连续使用时间	Low: 90 min High: 60 min with BL1850B x2

DRC200 Robotic Cleaner

Able to clean surface area of **500m²** with BL1850B x2



About 6 badminton courts

Large Capacity
2.5L

Continuous Usage Time
with BL1850B x2
(Normal Speed)

200min
(approx.)



DRC200Z

Robotic Cleaner

Pembersih Robotik
充电式智能吸尘器

- Able to clean an area of 300m² per 120 min with a coverage rate of 80%



Standard Equipment: Wireless remote controller (including two AAA alkaline batteries), Side Brush, Boundary Tape

• Z: Without Charger & Battery



Max Cleaning Area Kawasan Pembersihan Maksimum 最大清洁面积	BL1850B x2 : 500m ²
Max Running Speed Kelajuan Operasi Maksimum 最大运行速度	0.3m/ sec
Dust Box Capacity Kapasiti 容量	2.5L
Dimensions (L x W x H) Dimensi 体积	460x460x180mm (18-1/8"x18-1/8"x7-1/8")
Net Weight Berat Bersih 淨重	7.3kg (16.1lbs)
Continuous Usage Time (approx.) Masa Penggunaan Berterusan 连续使用时间	200 min with BL1850B x2



DRC200

Models and specs may vary by country

* All list price shown are for reference only (exclude SST).

* Semua harga yang ditunjukkan adalah untuk rujukan sahaja (tidak termasuk SST). 所有显示的建议零售价仅供参考 (不包括SST)。

Cordless
Tempa Kord 无线电

LED Flashlight
Lampu Suluh LED
LED照明灯

Vacuum Cleaner
Pembersih Vakum
吸尘器

Drilling / Fastening
Cetus / Pengikat
钻孔 / 紧固

Impact Drilling / Demolition
Cetus / Pencerak
打桩机 / 破拆机

Cutting
Pemotong
切割机

Grinding / Sanding
Pengiraian / Palsan
打磨 / 砂磨

Sawing
Gergaji
锯切

Planing / Routing
Pengiraian / Tumpang
刨平 / 压光

Others
Lain-lain
其他

Outdoor Power Equipment
Alatan Kertila Luar
园具





Li-ion Ah 6.0 5.0 4.0 3.0 2.0 1.5

DVC560 Cordless Upright Cleaner

High dust pick-up rate

4 rows of V-shaped bristle increase dust pick-up rate, suction power is even across the entire cleaning width due to the suction port located at the center

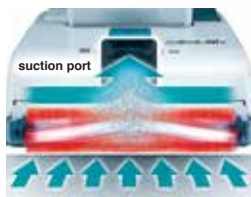

Max Sealed Suction

12kPa

Two different BL motors

- One for vacuuming dust and the other for rotating brushroll
- Two motors are separately controlled according to the selected suction mode



Vacuuming dust

Rotating brushroll

Continuous Usage Time with BL1860B x2 (Low Noise)

120min (approx.)



DVC560Z

Cordless Upright Cleaner

Pembersih Tegak Tanpa Kord
充电直立式吸尘器

- Low noise mode allows for use in noise-sensitive environments such as office, hospital and more

Standard Equipment: Long Sash Nozzle, Round Brush, Filter Bag, Filter H (HEPA Filter)

• Z: Without Charger & Battery



Capacity Kapasiti 尘袋容量	Dust: 5L
Max Air Flow Aliran Udara 最大空气流量	1.9m³/min
Max Sealed Suction Sedutan Terkedap 最大密封吸力	12kPa
Suction Power Kuasa Sedutan 吸力	Max: 85W Normal: 50W Low Noise: 25W
Dust Pick-Up Rate Kadar Pengumpulan Debu 除尘率	Max: 47 Normal: 44 Low Noise: 40
Cleaning Width Lebar Pembersihan 清洁宽度	318mm
Brushroll Rotation Speed Kelajuan Putaran Brushroll 毛刷转速	Max: 3,500RPM Normal: 2,500RPM Low Noise: 1,000RPM
Dimensions (L x W x H) Dimensi 体积	326x318x1,146mm (12-7/8x12-1/2x45")
Net Weight Berat Bersih 净重	8.3 - 9.0kg (18.3 - 19.8lbs.)
Continuous Usage Time (approx.) Masa Penggunaan Berterusan 连续使用时间	Max: 25 min Normal: 50 min Low Noise: 100 min with BL1850B x2

DCL501Z

Cordless Cyclone Cleaner

Pembersih Vakum Cyclone
Tanpa Kord
充电式旋风吸尘器

- Quiet operation for operator comfort

Standard Equipment: Shoulder Belt, Crevice Nozzle, Cleaning Brush, Floor Nozzle, Zoom Pipe, Hose, Hose Hook

• Z: Without Charger & Battery



Capacity Kapasiti 容量	250mL
Max Air Flow Aliran Udara 最大空气流量	1.2m³/min
Max Sealed Suction (water column) Sedutan Terkedap (Turus Air) 最大密封吸力(水柱)	10kPa (1,020mmH ₂ O)
Suction Power Kuasa Sedutan 吸力	High: 75W Low: 25W
Dimensions (L x W x H) Dimensi 体积	352x189x252mm (13-7/8"x7-7/16"x9-7/8")
Net Weight Berat Bersih 净重	3.1kg (6.8 lbs.)
Continuous Usage Time (approx.) Masa Penggunaan Berterusan 连续使用时间	Low: 64 min High: 29 min with BL1850B

DCL500Z

Cordless Cyclone Cleaner

Pembersih Vakum Cyclone
Tanpa Kord
充电式旋风吸尘器

- HEPA Clean Filter offers maximum performance for residential and commercial applications

Standard Equipment: Shoulder Belt, Crevice Nozzle, Floor Nozzle, Zoom Pipe, Hose, Hose Hook

• Z: Without Charger & Battery



Capacity Kapasiti 容量	250mL
Max Air Flow Aliran Udara 最大空气流量	1.3m³/min
Max Sealed Suction (water column) Sedutan Terkedap (Turus Air) 最大密封吸力(水柱)	6.6kPa (660mmH ₂ O)
Suction Power Kuasa Sedutan 吸力	High: 75W Low: 25W
Dimensions (L x W x H) Dimensi 体积	352x189x252mm (13-7/8"x7-7/16"x9-7/8")
Net Weight Berat Bersih 净重	3.6kg (7.9 lbs.)
Continuous Usage Time (approx.) Masa Penggunaan Berterusan 连续使用时间	Low: 50 min High: 20 min with BL1850B



VIDEO CLIP Models and specs may vary by country

DVC860/DCL500

* All list price shown are for reference only (exclude SST).

* Semua harga yang ditunjukkan adalah untuk rujukan sahaja (tidak termasuk SST). 所有显示的建议零售价仅供参考 (不包括SST)。

Cordless
Tanggap Kord 无线式

LED Flashlight
Lampu Sinar LED
LED 手电筒

Vacuum Cleaner
Pembersih Vakum
吸尘器

Drilling | Fastening
Ganda | Pengikat
钻孔 | 紧固

Impact Drilling | Demolition
Ganda | Pemecah
冲击钻孔 | 拆除加工

Cutting
Pemotong
切割

Grinding | Sanding
Pengkilat | Pasukan
打磨 | 磨光

Sawing
Ganda
锯切

Planing | Routers
Pengkilat | Tengking
刨削 | 雕刻

Others
Lain-lain
其他

Outdoor Power Equipment
Alatan Kerja Luar
园具/户外





CL002G / CL001G Cordless Cleaner

Redesigned Floor/ Carpet T-nozzle

- Redesigned structure reduces the resistance caused by suction, providing smooth running
- Redesigned inside air flow path reduces the noise made inside the nozzle

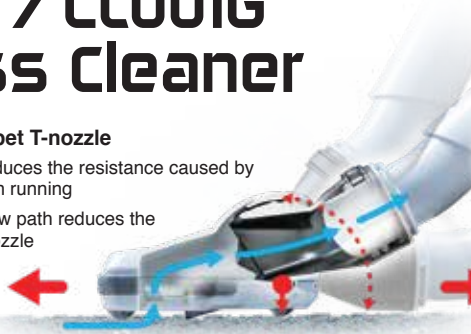

Continuous Usage Time
with BL4040 (Mode 1)

128min
(approx.)



Cyclone attachment (optional)

Centrifugal force separates fine dust, allowing the main unit of the cleaner to require about 80% less frequent dust disposal

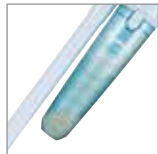

Cyclone pre-separation system separates dust from air



Easy disposal of the fine dust collected in dust case

Paper dust bag type (CL002G)

High performance dust bag set
High-performance dust bag that matches the shape of the dust collection space of the high vacuum model



Capsule type (CL001G)

HEPA filter is available
HEPA filter



Pre-filter



or



Easy shake off filter B set

+

HEPA filter



Suction Power
Mode 4
125w

Pipe locking mechanism

Pipe is fixed with the locking mechanism to prevent it from accidentally coming off

CL002GA117 | CL002GA104 | CL002GZ03 | CL002GZ07

Cordless Cleaner
Pembersih Vakum Tanpa Kord
充电式吸尘器



*Recommended batteries 2.0Ah, 2.5Ah, 4.0Ah



- Increased 125W suction power achieved by using 40Vmax XGT battery

Standard Equipment: Floor Nozzle, Sash Nozzle, Sash Nozzle Holder, Pipe, High Performance Dust Bag, Paper Dust Bag 5pcs (194566-1)

- GA117: 1x Standard Charger, 1x 2.0Ah Battery (White)
- GA104: 1x Standard Charger, 1x 2.0Ah Battery (Black)
- GZ03: Without Charger & Battery (Black)
- GZ07: Without Charger & Battery (White)



CL002G



VIDEO CLIP
Models and specs may vary by country

Capacity Kapasiti 容量	Cloth dust bag: 500mL Paper dust bag: 330mL
Max Air Flow Aliran Udara 最大空气流量	1.2m ³ /min
Max Sealed Suction (water column) Sedutan Terkedap (Turus Air) 最大密封吸力(水柱)	21kPa (2,100mmH ₂ O)
Suction Power Kuasa Sedutan 吸力	4: 125W 3: 70W 2: 45W 1: 20W
Dimensions (L x W x H) Dimensi 体积	1,081x114x158mm (42-1/2x4-1/2x6-1/4")
Net Weight Berat Bersih 净重	1.8 - 3.0kg (4.0 - 6.6lbs.)
Continuous Usage Time (approx.) Masa Penggunaan Berterusan 连续使用时间	4: 25 min 3: 40 min 2: 64 min 1: 128 min with BL4040

CL001GA127 | CL001GA116 | CL001GZ04 | CL001GZ10

Cordless Cleaner
Pembersih Vakum Tanpa Kord
充电式吸尘器



*Recommended batteries 2.0Ah, 2.5Ah, 4.0Ah



- Increased 125W suction power achieved by using 40Vmax XGT battery

Standard Equipment: Floor Nozzle, Sash Nozzle, Sash Nozzle Holder, Pipe, Easy Shake Off Filter B set

- GA127: 1x Standard Charger, 1x 2.0Ah Battery (White)
- GA116: 1x Standard Charger, 1x 2.0Ah Battery (Black)
- GZ04: Without Charger & Battery (Black)
- GZ10: Without Charger & Battery (White)



Capacity Kapasiti 容量	730mL
Max Air Flow Aliran Udara 最大空气流量	1.2m ³ /min
Max Sealed Suction (water column) Sedutan Terkedap (Turus Air) 最大密封吸力(水柱)	21kPa (2,100mmH ₂ O)
Suction Power Kuasa Sedutan 吸力	4: 125W 3: 70W 2: 45W 1: 20W with Easy Shake Off Filter
Dimensions (L x W x H) Dimensi 体积	1,066x113x152mm (42x4-7/16x6")
Net Weight Berat Bersih 净重	1.7 - 2.3 kg (3.5 - 5.1 lbs.)
Continuous Usage Time (approx.) Masa Penggunaan Berterusan 连续使用时间	4: 25 min 3: 40 min 2: 64 min 1: 128 min with BL4040

* All list price shown are for reference only (exclude SST).

* Semua harga yang ditunjukkan adalah untuk rujukan sahaja (tidak termasuk SST). 所有显示的建议零售价仅供参考 (不包括SST)。

Cordless
Tanpa Kord 无线

LED Flashlight
Lampu Sash LED
LED照灯

Vacuum Cleaner
Pembersih Vakum
吸尘器

Drilling / Fastening
Gergaji / Pengikat
电钻 / 螺絲

Impact Drilling / Demolition
Gergaji / Perseki
电钻 / 电锤

Cutting
Pemotong
切割机

Grinding / Sanding
Pengkilan / Pasir
砂磨 / 砂

Sawing
Gergaji
电锯

Planing / Routing
Pengkilan / Tumpang
刨花 / 磨花

Others
Lain-lain
其他

Outdoor Power Equipment
Alatan Kuasa Luar
户外动力



Cordless
Tanjak Roda Bebas

LED Flashlight
Lampu Senter LED
LED 超亮光

Vacuum Cleaner
Penyerbuk Vakuum
吸尘器

Drilling | Fastening
Dauri | Pengekat
钻孔 | 紧固

Impact Drilling | Demolition
Dauri | Pencah
取土钻孔 | 拆墙加工

Cutting
Penyunat
切割

Grinding | Sanding
Pengam | Pelekan
研磨 | 砂磨

Sawing
Dergaji
锯切

Planing | Routing
Pengam | Tanggapan
刨削 | 榫削

Others
Lain-lain
其他

Outdoor Power Equipment
Alatan Kuasa Luar
园具·户外

Makita

CAPSULE TYPE

Jenis Kapsul 胶囊型



No need to use paper bag.
This is a cost saving for repeated use
Tidak perlu menggunakan beg debu kertas,
boleh digunakan semula untuk menjimatkan kos
无需纸袋, 可重复使用以节省成本

TRIGGER SWITCH

Suis Pemicu 扳机开关



Ergonomic Handle With Easy On/ Off Trigger Switch
Pemegang ergonomik dengan suis pemicu hidup/
mati mudah 符合人体工学的手柄, 扳机开关



Filter (198915-4)



Pre Filter (198750-0)
(198751-8)

OR



Easy Shake Off Dust Filter (455176-2)

OR



Easy Shake Off Filter B Set (199966-0)

+



HEPA filter Filter H set (199989-8)

For capsule type (Except CL183D)

CAPSULE TYPE

Jenis Kapsul 胶囊型



No need to use paper bag.
This is a cost saving for repeated use
Tidak perlu menggunakan beg debu kertas,
boleh digunakan semula untuk menjimatkan kos
无需纸袋, 可重复使用以节省成本

SWITCH BUTTON

Butang Suis 开关按钮



Simply push a power on button for continuous use
Hanya tekan butang kuasa untuk kegunaan berterusan 一按式开关就能持续使用



Filter (198915-4)



Pre Filter (198750-0)
(198751-8)

OR



Easy Shake Off Dust Filter (455176-2)

OR



Easy Shake Off Filter B Set (199966-0)

+



HEPA filter Filter H set (199989-8)

For capsule type (Except CL183D)

DUST BAG TYPE

Beg Debu Penapis 尘袋型



Simply by open the front cover for easy dust bag change
Hanya dengan membuka penutup depan untuk menukar beg habuk dengan mudah
打开前盖, 简便更换尘袋

SWITCH BUTTON

Butang Suis 开关按钮



Simply push a power on button for continuous use
Hanya tekan butang kuasa untuk kegunaan berterusan 一按式开关就能持续使用



Paper Filter
5pcs (194566-1)
10pcs (194565-3)

OR



Dust Bag (198746-1)

OR



(Except CL002G)
Easy Shake Off Dust Bag (198748-7)

OR



(For CL002G only)
High Performance Dust Bag (1910M4-5)



DCL280

Suction Power
Kuasa Sedutan 吸力

45w

Large Capacity
Kapasiti Besar 最大容量

750mL

Net Weight
Berat Bersih 淨重

1.2kg



DCL180

Suction Power
Kuasa Sedutan 吸力

30w

Large Capacity
Kapasiti Besar 最大容量

650mL

Net Weight
Berat Bersih 淨重

1.2kg



CL001G

Suction Power
Kuasa Sedutan 吸力

125w

Large Capacity
Kapasiti Besar 最大容量

730mL

Net Weight
Berat Bersih 淨重

1.7 kg



DCL281F

Suction Power
Kuasa Sedutan 吸力

60w

Large Capacity
Kapasiti Besar 最大容量

750mL

Net Weight
Berat Bersih 淨重

1.2kg



DCL181F

Suction Power
Kuasa Sedutan 吸力

30w

Large Capacity
Kapasiti Besar 最大容量

650mL

Net Weight
Berat Bersih 淨重

1.2kg



CL002G

Suction Power
Kuasa Sedutan 吸力

125w

Large Capacity
Kapasiti Besar 最大容量

500mL

Net Weight
Berat Bersih 淨重

1.8kg



DCL282F

Suction Power
Kuasa Sedutan 吸力

60w

Large Capacity
Kapasiti Besar 最大容量

500mL

Net Weight
Berat Bersih 淨重

1.3kg



DCL182

Suction Power
Kuasa Sedutan 吸力

30w

Large Capacity
Kapasiti Besar 最大容量

500mL

Net Weight
Berat Bersih 淨重

1.2kg



* All list price shown are for reference only (exclude SST).

* Semua harga yang ditunjukkan adalah untuk rujukan sahaja (tidak termasuk SST). 所有显示的建议零售价仅供参考 (不包括SST)。



CL106FD

Suction Power
Kuasa Sedutan 吸力

19_w

Large Capacity
Kapasiti Besar 最大容量

600_{mL}

Net Weight
Berat Bersih 淨重

1.0_{kg}



CL100D

Suction Power
Kuasa Sedutan 吸力

14_w

Large Capacity
Kapasiti Besar 最大容量

600_{mL}

Net Weight
Berat Bersih 淨重

0.88_{kg}



BUILT-IN LITHIUM-ION BATTERY

CL111D

Suction Power
Kuasa Sedutan 吸力

21_w

Large Capacity
Kapasiti Besar 最大容量

560_{mL}

Net Weight
Berat Bersih 淨重

0.94_{kg}



CL070D

Suction Power
Kuasa Sedutan 吸力

14_w

Large Capacity
Kapasiti Besar 最大容量

600_{mL}

Net Weight
Berat Bersih 淨重

0.81_{kg}



CL108FD

Suction Power
Kuasa Sedutan 吸力

30_w

Large Capacity
Kapasiti Besar 最大容量

600_{mL}

Net Weight
Berat Bersih 淨重

1.0_{kg}



CL107FD

Suction Power
Kuasa Sedutan 吸力

32_w

Large Capacity
Kapasiti Besar 最大容量

500_{mL}

Net Weight
Berat Bersih 淨重

1.1_{kg}



BUILT-IN LITHIUM-ION BATTERY

CL114FD

Suction Power
Kuasa Sedutan 吸力

35_w

Large Capacity
Kapasiti Besar 最大容量

500_{mL}

Net Weight
Berat Bersih 淨重

1.1_{kg}



CL102D

Suction Power
Kuasa Sedutan 吸力

14_w

Large Capacity
Kapasiti Besar 最大容量

500_{mL}

Net Weight
Berat Bersih 淨重

1.1_{kg}



BUILT-IN LITHIUM-ION BATTERY

CL104D CL105D

Suction Power
Kuasa Sedutan 吸力

20_w

Large Capacity
Kapasiti Besar 最大容量

500_{mL}

Net Weight
Berat Bersih 淨重

1.1_{kg}



Cordless
Tapis Kord 无线式

LED Flashlight
Lampu Suka LED
LED照灯

Vacuum Cleaner
Pembersih Vakuum
吸尘器

Drilling / Fastening
Gabus / Pengikat
钻孔 / 紧固

Impact Drilling / Demolition
Gabus / Persekok
打桩钻孔 / 拆毁加工

Cutting
Pemotong
切割

Grinding / Sanding
Pengkilan / Palsan
打磨 / 砂磨

Sawing
Gergaji
锯切

Planing / Routing
Pengyalan / Tonggolan
刨削 / 雕刻

Others
Lain-lain
其他

Outdoor Power Equipment
Alatan Kerdil Luar
园机 / 户外



* All list price shown are for reference only (exclude SST).

* Semua harga yang ditunjukkan adalah untuk rujukan sahaja (tidak termasuk SST). 所有显示的建议零售价仅供参考 (不包括SST)。



Li-ion Ah 6.0 | 5.0 | 4.0 | 3.0 | 2.0 | 1.5

DCL282FZW | DCL282FZ

Cordless Cleaner
Pembersih Vakum Tanpa Kord
充电式吸尘器



DCL282FZW



DCL282FZ

- Increased suction power achieved by using highly efficient BL motor

Standard Equipment: Floor Nozzle, Sash Nozzle, Sash Nozzle Holder, Pipe, Easy Shake Off Dust Bag, Paper Dust Bag, Hand Strap

- FZW: Without Charger & Battery (White)
- FZ: Without Charger & Battery (Blue)



Capacity Kapasiti 容量	Normal Dust Bag: 500mL Paper Dust Bag: 330mL
Max Air Flow Aliran Udara 最大空气流量	1.5m ³ /min
Max Sealed Suction (water column) Sedutan Terkepad (Turus Air) 最大密封吸力(水柱)	8.2kPa (820mmH ₂ O)
Suction Power Kuasa Sedutan 吸力	Max: 60W High: 45W Normal: 15W with Normal Dust Bag
Dimensions (L x W x H) Dimensi 体积	1,016 x 114 x 154 mm (40 x 4-1/2 x 6-1/16")
Net Weight Berat Bersih 淨重	1.3 - 1.6 kg (2.8 - 3.5 lbs.)
Continuous Usage Time (approx.) Masa Penggunaan Berterusan 连续使用时间	Normal: 50 min High: 20 min Max: 15 min with BL1830B

DCL281FZW | DCL281FZB | DCL281FZ

Cordless Cleaner
Pembersih Vakum Tanpa Kord
充电式便携吸尘器



DCL281FZW



DCL281FZ

- Increased suction power achieved by using highly efficient BL motor

Standard Equipment: Floor Nozzle, Sash Nozzle, Sash Nozzle Holder, Pipe, Prefilter, Filter H Set (HEPA Filter)

- FZW: Without Charger & Battery (White)
- FZB: Without Charger & Battery (Black)
- FZ: Without Charger & Battery (Blue)



DCL281FZB

Capacity Kapasiti 容量	750mL
Max Air Flow Aliran Udara 最大空气流量	1.5m ³ /min
Max Sealed Suction (water column) Sedutan Terkepad (Turus Air) 最大密封吸力(水柱)	8.2kPa (820mmH ₂ O)
Suction Power Kuasa Sedutan 吸力	Max: 60W High: 45W Normal: 15W with Normal Filter Max: 55W High: 40W Normal: 13W with Easy Shake Off Filter
Dimensions (L x W x H) Dimensi 体积	1,016x113x154mm (40"x4-7/16"x6-1/6")
Net Weight Berat Bersih 淨重	1.2 - 1.6kg (2.7 - 3.5lbs.)
Continuous Usage Time (approx.) Masa Penggunaan Berterusan 连续使用时间	Max: 25 min High: 33 min Normal: 83 min with BL1850B

DCL280FZW | DCL280FZB | DCL280FZ

Cordless Cleaner
Pembersih Vakum Tanpa Kord
充电式便携吸尘器



DCL280FZW



DCL280FZ

- Increased suction power achieved by using highly efficient BL motor

Standard Equipment: Floor Nozzle, Sash Nozzle, Sash Nozzle Holder, Pipe, Prefilter, Filter H Set (HEPA Filter)

- FZW: Without Charger & Battery (White)
- FZB: Without Charger & Battery (Black)
- FZ: Without Charger & Battery (Blue)



DCL280FZB

Capacity Kapasiti 容量	750mL
Max Air Flow Aliran Udara 最大空气流量	1.4m ³ /min
Max Sealed Suction (water column) Sedutan Terkepad (Turus Air) 最大密封吸力(水柱)	6.4kPa (640mmH ₂ O)
Suction Power Kuasa Sedutan 吸力	Normal Filter: 45W Easy Shake Off Filter: 40W
Dimensions (L x W x H) Dimensi 体积	1,016x113x154mm (40"x4-7/16"x6-1/6")
Net Weight Berat Bersih 淨重	1.2 - 1.6kg (2.7 - 3.5lbs.)
Continuous Usage Time (approx.) Masa Penggunaan Berterusan 连续使用时间	33 min with BL1850B

DCL181FZW

Cordless Cleaner
Pembersih Vakum Tanpa Kord
充电式便携吸尘器



DCL181FZW



- Strong suction power for fast cleaning with more run time

Standard Equipment: Floor Nozzle, Sash Nozzle, Sash Nozzle Holder, Pipe, Filter, Prefilter, Stay

- FZW: Without Charger & Battery (White)



Capacity Kapasiti 容量	650mL
Max Air Flow Aliran Udara 最大空气流量	1.4m ³ /min
Max Sealed Suction (water column) Sedutan Terkepad (Turus Air) 最大密封吸力(水柱)	5.3kPa (540mmH ₂ O)
Suction Power Kuasa Sedutan 吸力	High: 30W Low: 11W
Dimensions (L x W x H) Dimensi 体积	999x114x152mm (39-1/4"x4-1/2"x6")
Net Weight Berat Bersih 淨重	1.2 - 1.4kg (2.7 - 3.1lbs.)
Continuous Usage Time (approx.) Masa Penggunaan Berterusan 连续使用时间	Low: 66 min High: 33 min with BL1850B

DCL180FRFW | DCL180RFB | DCL180ZB | DCL180Z

Cordless Cleaner
Pembersih Vakum Tanpa Kord
充电式便携吸尘器



DCL180FRFW



DCL180Z

- Strong suction power for fast cleaning

Standard Equipment: FRFW: Floor Nozzle, Sash Nozzle, Sash Nozzle Holder, Pipe, Stay, Easy Shake Off Filter
RFB / ZB / Z: Floor Nozzle, Sash Nozzle, Sash Nozzle Holder, Pipe, Stay, Filter, Prefilter

- FRFW: 1x Rapid Charger, 1x 3.0Ah Battery (White)
- RFB: 1x Rapid Charger, 1x 3.0Ah Battery (Black)
- ZB: Without Charger & Battery (Black)
- Z: Without Charger & Battery (Blue)

Only for DCL180FRFW

DCL180RFB / ZB



Capacity Kapasiti 容量	650mL
Max Air Flow Aliran Udara 最大空气流量	1.4m ³ /min
Max Sealed Suction (water column) Sedutan Terkepad (Turus Air) 最大密封吸力(水柱)	4.2kPa (428mmH ₂ O)
Suction Power Kuasa Sedutan 吸力	30W
Dimensions (L x W x H) Dimensi 体积	999x114x152mm (39-1/4"x4-1/2"x6")
Net Weight Berat Bersih 淨重	1.2kg (2.7 lbs)
Continuous Usage Time (approx.) Masa Penggunaan Berterusan 连续使用时间	33 min with BL1850B

* All list price shown are for reference only (exclude SST).

* Semua harga yang ditunjukkan adalah untuk rujukan sahaja (tidak termasuk SST). 所有显示的建议零售价仅供参考 (不包括SST)。

18V

LXT

12V_{max}

CXT

Li-ion Ah 6.0 5.0 4.0 3.0 2.0 1.5

DCL182FRFW | DCL182FZW

Cordless Cleaner
Pembersih Vakum Tanpa Kord
充电式便携吸尘器



18V

- Improved front cover opens with push button for easier access

Standard Equipment: Floor Nozzle, Sash Nozzle, Sash Nozzle Holder, Pipe, Dust Bag, Paper Dust Bag 5pcs

- FRFW: 1x Rapid Charger, 1x 3.0Ah Battery (White)
- FZW: Without Charger & Battery (White)



Capacity Kapasiti 容量	Dust Bag: 500mL Paper Pack: 330mL
Max Air Flow Aliran Udara 最大空气流量	1.4m ³ /min
Max Sealed Suction (water column) Sedutan Terkedap (Turus Air) 最大密封吸力(水柱)	5.4kPa (551mmH ₂ O)
Suction Power Kuasa Sedutan 吸力	High: 30W Low: 11W
Dimensions (L x W x H) Dimensi 体积	1,004x115x151mm (39-1/2"x4-1/2"x5-15/16")
Net Weight Berat Bersih 净重	1.3kg (2.8 lbs)
Continuous Usage Time (approx.) Masa Penggunaan Berterusan 连续使用时间	Low: 66 min High: 33 min with BL1850B

DVC750LZX1

Cordless Portable Vacuum Cleaner (Wet & Dry)
Pembersih Vakum Tanpa Kord
(Basah dan Kering)
充电式轻便吸尘器(干湿两用)



18V

WET
Basah 湿

DRY
Kering 干



VIDEO CLIP
Models and specs may vary by country

DVC750

- Two tools in one; quickly converts from vacuum to blower for increased versatility

Standard Equipment: Hose, Wide Nozzle, Sash Nozzle, *HEPA Filter (162518-0) *Dry only

- LZX1: 1x Shoulder Belt, Without Charger & Battery



Capacity Kapasiti 容量	Dust: 7.5L
Max Air Flow Aliran Udara 最大空气流量	High: 1.6m ³ /min Normal: 1.3m ³ /min
Max Sealed Suction Sedutan Terkedap (Turus Air) 最大密封吸力(水柱)	High: 6.7kPa Normal: 4.2kPa
Suction Power Kuasa Sedutan 吸力	High: 50W Normal: 25W
Dimensions (L x W x H) Dimensi 体积	418x251x278mm (16-1/2"x9-7/8"x11")
Net Weight Berat Bersih 净重	4.3 - 4.6kg (9.4 - 10.1 lbs.)
Continuous Usage Time (approx.) Masa Penggunaan Berterusan 连续使用时间	Normal: 60 min High: 30 min with BL1850B

ACCESSORIES
(Optional)

Wet Filter Set
(Wet Only)
Part No. 191M39-3



DVC350Z

Cordless Vacuum Cleaner
Pembersih Vakum Tanpa Kord
充电式吸尘器



18V

- Large 3L dust bag capacity

Standard Equipment: Nozzle assembly, Dust Bag Assembly, Hose, Shoulder Belt

- Z: Without Charger & Battery



Max Peak Air Flow Aliran Udara 最大空气流量	3.4m ³ /min
Max Sealed Suction (water column) Sedutan Terkedap (Turus Air) 最大密封吸力(水柱)	5.5kPa (560mmH ₂ O)
Recoverable Capacity Kapasiti 容量	Dust: 3L
Dimensions (L x W x H) Dimensi 体积	273x195x226mm (10-3/4"x7-5/8"x8-7/8")
Net Weight Berat Bersih 净重	2.2kg (4.8lbs)
Continuous Usage Time (approx.) Masa Penggunaan Berterusan 连续使用时间	Low: 43 min High: 22 min with BL1850B



VIDEO CLIP
Models and specs may vary by country

DVC350/DVC260

DCL184Z

Cordless Cleaner
Pembersih Vakum Tanpa Kord
充电式吸尘器



18V

- Higher suction power and longer continuous run time

Standard Equipment: Seat Nozzle, Mat Nozzle, Rubber Nozzle, Soft Brush, Blower Attachment, Dust Bag, Paper Dust Bag 5pcs (194566-1), Shoulder Belt

- Z: Without Charger & Battery



VIDEO CLIP
Models and specs may vary by country

DCL184



Capacity Kapasiti 容量	Cloth Dust Bag: 500mL Paper Dust Bag: 330mL
Max Air Flow Aliran Udara 最大空气流量	1.4m ³ /min
Max Sealed Suction (water column) Sedutan Terkedap (Turus Air) 最大密封吸力(水柱)	5.4kPa (550mmH ₂ O)
Suction Power Kuasa Sedutan 吸力	Max: 38W High: 23W Normal: 5W
Dimensions (L x W x H) Dimensi 体积	365x138x202mm (14-3/8"x5-7/16"x8")
Net Weight Berat Bersih 净重	1.8 - 2.2kg (4.0 - 4.9lbs.)
Continuous Usage Time (approx.) Masa Penggunaan Berterusan 连续使用时间	Max: 33 min High: 50 min Normal: 133 min with BL1850B

CL121DZ

Cordless Cleaner
Pembersih Vakum Tanpa Kord
充电式吸尘器



12V_{max}

- Comes with a variety of special nozzles optimum for cleaning car interior

Standard Equipment: Mat Nozzle, Seat Nozzle, Rubber Nozzle, Soft Brush, Blower Nozzle, Dust Bag, Paper Dust Bag 5pcs (194566-1), Shoulder Belt

- DZ: Without Charger & Battery



VIDEO CLIP
Models and specs may vary by country

CL121D



Capacity Kapasiti 容量	Dust Bag: 500mL Paper Pack: 330mL
Max Air Flow Aliran Udara 最大空气流量	1.3m ³ /min
Max Sealed Suction (water column) Sedutan Terkedap (Turus Air) 最大密封吸力(水柱)	4.6kPa (470 mmH ₂ O)
Suction Power Kuasa Sedutan 吸力	Max: 28W High: 19W Normal: 5W
Dimensions (L x W x H) Dimensi 体积	345x138x202mm (13-5/8"x5-7/16"x8")
Net Weight Berat Bersih 净重	1.7 - 1.8kg (3.7 - 4.0lbs.)
Continuous Usage Time (approx.) Masa Penggunaan Berterusan 连续使用时间	Normal: 67 min High: 32 min Max: 27 min with BL1041B

* All list price shown are for reference only (exclude SST).

* Semua harga yang ditunjukkan adalah untuk rujukan sahaja (tidak termasuk SST). 所有显示的建议零售价仅供参考 (不包括SST)。

Cordless
Tanpa Kord 无线

LED Flashlight
Lampu Suhu LED
LED 闪光灯

Vacuum Cleaner
Pembersih Vakum
吸尘器

Drilling / Fastening
Gantol / Pengikat
钻头 / 紧固件

Impact Drilling / Demolition
Gantol / Pemecah
冲击钻头 / 破拆钻头

Cutting
Pemotong
切割机

Grinding / Sanding
Pengkilan / Poles
研磨 / 打磨

Sanding
Gantol
磨头

Planing / Routing
Pengkilan / Tumpang
刨头 / 压头

Others
Lain-lain
其他

Outdoor Power Equipment
Alatan Kuasa Luar
户外动力工具



12V_{max}CXT[®]

10.8V

CL108FDWYW | CL108FDZW

Cordless Cleaner

Pembersih Vakum Tanpa Kord
充电式便携吸尘器12V_{max}

- Compact and High Suction Power

Standard Equipment: Floor Nozzle, Sash Nozzle,
Sash Nozzle Holder, Pipe, Filter, Prefilter

- FDWYW: 1x Standard Charger, 1x 1.5Ah Battery (White)
- FDZW: Without Charger & Battery (White)



Capacity Kapasiti 容量	600mL
Max Air Flow Aliran Udara 最大空气流量	1.2m ³ /min
Max Sealed Suction (water column) Sedutan Terkedap (Turus Air) 最大密封吸力(水柱)	4.4kPa (445mmH ₂ O)
Suction Power Kuasa Sedutan 吸力	Max: 30W High: 20W Normal: 5W
Dimensions (L x W x H) Dimensi 体积	956x110x150mm (37-5/8"x4-5/16"x5-7/8")
Net Weight Berat Bersih 淨重	1.0 - 1.2kg (2.3 - 2.7lbs.)
Continuous Usage Time (approx.) Masa Penggunaan Berterusan 连续使用时间	Normal: 33 min High: 16 min Max: 13 min with BL1021B

CL106FDWYW | CL106FDZW

Cordless Cleaner

Pembersih Vakum Tanpa Kord
充电式便携吸尘器12V_{max}

- Stronger suction power for faster cleaning with more run time

Standard Equipment: Floor Nozzle, Sash Nozzle,
Sash Nozzle Holder, Pipe, Filter, Prefilter

- FDWYW: 1x Standard Charger, 1x 1.5Ah Battery (White)
- FDZW: Without Charger & Battery (White)



Capacity Kapasiti 容量	600mL
Max Air Flow Aliran Udara 最大空气流量	1.3m ³ /min
Max Sealed Suction (water column) Sedutan Terkedap (Turus Air) 最大密封吸力(水柱)	3.1kPa (316mmH ₂ O)
Suction Power Kuasa Sedutan 吸力	19W
Dimensions (L x W x H) Dimensi 体积	958x100x150mm (37-3/4"x3-15/16"x5-7/8")
Net Weight Berat Bersih 淨重	1.0kg (2.2 lbs.)
Continuous Usage Time (approx.) Masa Penggunaan Berterusan 连续使用时间	21 min with BL1021B

CL107FDWYW | CL107FDZW

Cordless Cleaner

Pembersih Vakum Tanpa Kord
充电式便携吸尘器12V_{max}

- 3 mode suction power settings

Standard Equipment: Floor Nozzle, Sash Nozzle, Sash Nozzle Holder,
Pipe, Dust Bag, Paper Dust Bag 5pcs (194566-1)

- FDWYW: 1x Standard Charger, 1x 1.5Ah Battery (White)
- FDZW: Without Charger & Battery (White)



Capacity Kapasiti 容量	Dust Bag: 500mL Paper Pack: 330mL
Max Air Flow Aliran Udara 最大空气流量	1.4m ³ /min
Max Sealed Suction (water column) Sedutan Terkedap (Turus Air) 最大密封吸力(水柱)	5.0kPa (510mmH ₂ O)
Suction Power Kuasa Sedutan 吸力	Max: 32W High: 20W Normal: 5W
Dimensions (L x W x H) Dimensi 体积	960x112x150mm (37-3/4"x4-3/8"x5-7/8")
Net Weight Berat Bersih 淨重	1.1kg (2.5lbs.)
Continuous Usage Time (approx.) Masa Penggunaan Berterusan 连续使用时间	Normal: 25 min High: 12 min Max: 10 min with BL1021B

CL114FDWI

Cordless Cleaner

Pembersih Vakum Tanpa Kord
充电式便携吸尘器12V_{max}With Built-in Battery
Dengan Bateri Terbina Dalam
内置电池

- Much higher 35W suction power due to 2.0Ah battery

Standard Equipment: Floor Nozzle,
Sash Nozzle, Sash Nozzle Holder, Pipe, Dust Bag,
Paper Dust Bag 5pcs (194566-1)

- DWI: 1x Standard Charger, Built-in 2.0Ah Battery (White)



Capacity Kapasiti 容量	Cloth Dust Bag: 500mL Paper Dust Bag: 330mL
Max Air Flow Aliran Udara 最大空气流量	1.4m ³ /min
Max Sealed Suction (water column) Sedutan Terkedap (Turus Air) 最大密封吸力(水柱)	5.0kPa (510mmH ₂ O)
Suction Power Kuasa Sedutan 吸力	Powerful: 35W High: 20W Low: 5W
Dimensions (L x W x H) Dimensi 体积	983x113x136mm (38-3/4"x4-7/16"x5-3/8")
Net Weight Berat Bersih 淨重	1.1kg (2.4lbs)
Continuous Usage Time (approx.) Masa Penggunaan Berterusan 连续使用时间	Normal: 55 min High: 18 min Powerful: 10 min with Built-in Lithium-ion Battery

CL100DW | CL100DZ

Cordless Cleaner

Pembersih Vakum Tanpa Kord
充电式便携吸尘器

10.8V

- Increased storage capacity for longer time between waste disposal

Standard Equipment: Floor Nozzle, Sash Nozzle,
Sash Nozzle Holder, Pipe, Filter, Prefilter

- DW: 1x Standard Charger, 1x 1.3Ah Battery (White)
- DZ: Without Charger & Battery (White)



Capacity Kapasiti 容量	600mL
Max Air Flow Aliran Udara 最大空气流量	1.3m ³ /min
Max Sealed Suction (water column) Sedutan Terkedap (Turus Air) 最大密封吸力(水柱)	2.3kPa (235mmH ₂ O)
Suction Power Kuasa Sedutan 吸力	14W
Dimensions (L x W x H) Dimensi 体积	966x103x150mm (38-1/32"x4-1/16"x5-7/8")
Net Weight Berat Bersih 淨重	0.88kg (1.94lbs)
Continuous Usage Time (approx.) Masa Penggunaan Berterusan 连续使用时间	12 min with BL1013

* All list price shown are for reference only (exclude SST).

* Semua harga yang ditunjukkan adalah untuk rujukan sahaja (tidak termasuk SST). 所有显示的建议零售价仅供参考 (不包括SST)。

10.8V

7.2V

CL102DW | CL102DZ

Cordless Cleaner

Pembersih Vakum Tanpa Kord
充电式便携吸尘器

10.8V

- Quick clean-ups with strong suction power

Standard Equipment: Floor Nozzle, Sash Nozzle, Sash Nozzle Holder, Pipe, Dust Bag, Paper Dust Bag 5pcs

- DW: 1x Standard Charger, 1x 1.3Ah Battery (White)
- DZ: Without Charger & Battery (White)

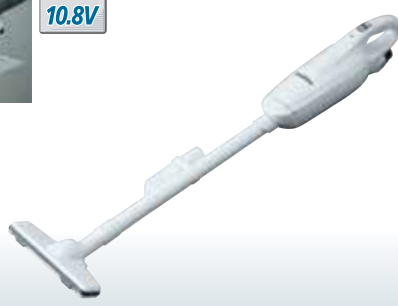

Capacity Kapasiti 容量	Dust Bag: 500mL Paper Pack: 330mL
Max Air Flow Aliran Udara 最大空气流量	1.1m ³ /min
Max Sealed Suction (water column) Sedutan Terkedap (Turus Air) 最大密封吸力(水柱)	2.7kPa (275mmH ₂ O)
Suction Power Kuasa Sedutan 吸力	High: 14W Low: 6W
Dimensions (L x W x H) Dimensi 体积	984x113x150mm (38-3/4"x4-7/16"x5-7/8")
Net Weight Berat Bersih 净重	1.1kg (2.4lbs)
Continuous Usage Time (approx.) Masa Penggunaan Berterusan 连续使用时间	Low: 21 min High: 13 min with BL1013

CL111DWI | CL111DWR

Cordless Cleaner

Pembersih Vakum Tanpa Kord
充电式便携吸尘器

10.8V

With Built-in Battery
Dengan Bateri Terbina Dalam
内置电池

- LED light indicates when to charge battery

Standard Equipment: Nozzle for Flooring & Carpet, Sash Nozzle, Sash Nozzle Holder, Pipe, Adapter

- DWI (Ivory): 1x Standard Charger, Built-in 1.5Ah Battery, Dust Bag, Paper Dust Bag 5pcs
- DWR (Red): 1x Standard Charger, Built-in 1.5Ah Battery, Filter, Prefilter



Capacity Kapasiti 容量	560mL
Max Air Flow Aliran Udara 最大空气流量	1.4m ³ /min
Max Sealed Suction (water column) Sedutan Terkedap (Turus Air) 最大密封吸力(水柱)	3.4kPa (350mmH ₂ O)
Suction Power Kuasa Sedutan 吸力	21W
Dimensions (L x W x H) Dimensi 体积	906x102x109mm (35-3/4"x4-7/16"x4-1/4")
Net Weight Berat Bersih 净重	0.94kg (2.1lbs.)
Continuous Usage Time (approx.) Masa Penggunaan Berterusan 连续使用时间	12 min with Built-in Lithium-ion Battery

CL104DWYX | CL104DWY

Cordless Cleaner

Pembersih Vakum Tanpa Kord
充电式便携吸尘器

10.8V

With Built-in Battery
Dengan Bateri Terbina Dalam
内置电池

- Increased storage capacity for longer time between waste disposal

Standard Equipment: Floor Nozzle, Sash Nozzle, Sash Nozzle Holder, Pipe, Dust Bag, Adapter (DC1001), Paper Dust Bag 5pcs (194566-1)

- DWYX: 1x Standard Charger, Built-in 1.5Ah Battery (Blue)
- DWY: 1x Standard Charger, Built-in 1.5Ah Battery (White)

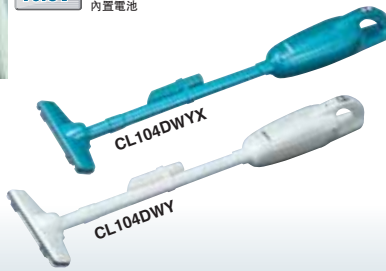

Capacity Kapasiti 容量	Dust Bag: 500mL Paper Pack: 330mL
Max Air Flow Aliran Udara 最大空气流量	1.1m ³ /min
Max Sealed Suction (water column) Sedutan Terkedap (Turus Air) 最大密封吸力(水柱)	3.3kPa (340mmH ₂ O)
Suction Power Kuasa Sedutan 吸力	Turbo: 20W High: 14W Low: 5W
Dimensions (L x W x H) Dimensi 体积	983x113x136mm (38-3/4"x4-7/16"x5-3/8")
Net Weight Berat Bersih 净重	1.1kg (2.3lbs)
Continuous Usage Time (approx.) Masa Penggunaan Berterusan 连续使用时间	Low: 30 min High: 15 min Turbo: 10 min with Built-in Lithium-ion Battery

CL105DW | CL105DWX

Cordless Cleaner

Pembersih Vakum Tanpa Kord
充电式便携吸尘器

10.8V

With Built-in Battery
Dengan Bateri Terbina Dalam
内置电池

- Strong suction power of 20W

Standard Equipment: Floor Nozzle, Sash Nozzle, Sash Nozzle Holder, Pipe, Dust Bag, Adapter (DC1001), Paper Dust Bag 5pcs (194566-1)

- DW: 1x Standard Charger, Built-in 1.3Ah Battery (White)
- DWX: 1x Standard Charger, Built-in 1.3Ah Battery (Blue)

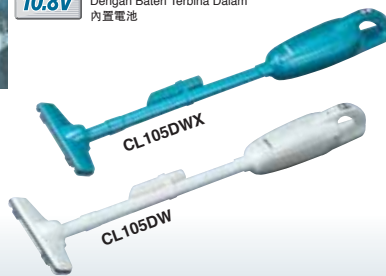

Capacity Kapasiti 容量	Dust Bag: 500mL Paper Pack: 330mL
Max Air Flow Aliran Udara 最大空气流量	1.1m ³ /min
Max Sealed Suction (water column) Sedutan Terkedap (Turus Air) 最大密封吸力(水柱)	3.3kPa (340mmH ₂ O)
Suction Power Kuasa Sedutan 吸力	Turbo: 20W High: 14W Low: 5W
Dimensions (L x W x H) Dimensi 体积	983x113x136mm (38-3/4"x4-7/16"x5-3/8")
Net Weight Berat Bersih 净重	1.1kg (2.3lbs)
Continuous Usage Time (approx.) Masa Penggunaan Berterusan 连续使用时间	Low: 20 min High: 10 min Turbo: 7 min with Built-in Lithium-ion Battery

CL070DZ

Cordless Cleaner

Pembersih Vakum Tanpa Kord
充电式便携吸尘器

7.2V

- Increased storage capacity for longer time between waste disposal

Standard Equipment: Floor Nozzle, Sash Nozzle, Sash Nozzle Holder, Pipe, Filter, Prefilter

- DZ: Without Charger & Battery (White)



Capacity Kapasiti 容量	600mL
Max Air Flow Aliran Udara 最大空气流量	1.2m ³ /min
Max Sealed Suction (water column) Sedutan Terkedap (Turus Air) 最大密封吸力(水柱)	1.8kPa (180mmH ₂ O)
Suction Power Kuasa Sedutan 吸力	14W
Dimensions (L x W x H) Dimensi 体积	966x103x142mm (38-1/32"x4-1/16"x5-5/8")
Net Weight Berat Bersih 净重	0.81kg (1.8lbs)
Continuous Usage Time (approx.) Masa Penggunaan Berterusan 连续使用时间	8 min with BL7010

* All list price shown are for reference only (exclude SST).

* Semua harga yang ditunjukkan adalah untuk rujukan sahaja (tidak termasuk SST). 所有显示的建议零售价仅供参考 (不包括SST)。

Cordless
Tanpa Kord 无线式LED Flashlight
Lampu Sash LED
LED照明灯Vacuum Cleaner
Pembersih Vakum
吸尘器Drilling / Fastening
Gergasi / Pengikat
钻孔 / 紧固Impact Drilling / Demolition
Gergasi / Penunjuk
打桩机 / 拆墙机Cutting
Pemotong
切割Grinding / Sanding
Pengkilan / Pasukan
打磨 / 磨光Sawing
Gergasi
锯切Planing / Routing
Pengkilan / Tunggul
刨光 / 雕花Others
Lain-lain
其他Outdoor Power Equipment
Alatan Kuasa Luar
户外动力设备Makita
MAKITA

Centrifugal force separates fine dust, allowing the main unit of the cleaner to require about 80% less frequent dust disposal

Daya sentrifugal memisahkan debu halus, mengurangkan kekerapan pembersihan penapis kira-kira 80%
 离心力将细小的灰尘分开, 使清洁器的主机减少了大约80%的频繁灰尘处理



Cyclone pre-separation system separates dust from air

Sistem pra-pemisahan siklon memisahkan debu dari udara
 旋风分离系统将灰尘与空气隔离



Dust case

Easy disposal of the fine dust collected in dust case

Debu halus dikumpulkan dalam pengumpul habuk mudah dibersihkan
 集尘箱中收集的细粉尘方便处理



The main unit of the cleaner requires much less frequent dust disposal

Mangurangkan kekerapan pembersihan pengumpul habuk
 减少清空集尘箱频率

Cyclone Attachment Set

Set Pengumpul Habuk Siklon 旋风集尘配件

Pipe lock

DCL280F, DCL281F, DCL282F

Part No. 191D71-3 (White)
 Part No. 191D73-9 (Black)



Dust capacity **400mL** / Net weight **0.36kg**

CL106FD, CL107FD, CL108FD, DCL180, DCL181F, DCL182, CL183D

Part No. 199491-1 (White)
 Part No. 191D75-5 (Black)



Dust capacity **400mL** / Net weight **0.35kg**

Easily fitting

Mudah dipasang 轻松拟合



With short pipe (Part No. 191D76-3)



With short pipe (Part No. 191D79-7)

Without standard pipe (Part No. 451241-5)

Suction Power Keep

90%*

*When used with DCL182 (wood dust)



By using this short pipe when attaching Cyclone attachment, you can use the cleaner with the same overall length as the cleaner without Cyclone attachment

Dengan menggunakan paip pendek ini apabila bersambung dengan set pengumpul habuk siklon, anda boleh menggunakan pembersih dengan panjang keseluruhan yang sama seperti pembersih tanpa set pengumpul habuk siklon
 安装旋风集尘配件时使用此短管, 可以使吸尘机的总长度与不安装旋风集尘配件的吸尘器相同

Battery Adapter BAP18C (191M50-5)

Able to transfer the battery weight from the cleaner to user's waist to reduce stress on his/her hand without reducing the run time

Specially for cleaner use

Compatible Batteries 18V : 1.5Ah to 6.0Ah

*Without Charger & Batteries

18V
LITHIUM-ION



Cordless
Tanpa Kabel / 无线式

LED Flashlight
Lampu Cahaya LED
LED 照明灯

Vacuum Cleaner
Pembersih Vakuum
吸尘器

Drilling / Fastening
Drobul / Pengikat
钻孔 / 紧固

Impact Drilling / Demolition
Drobul / Penembak
起工钻孔 / 拆墙加工

Cutting
Pemotong
切割

Grinding / Sanding
Pengisar / Pasiran
打磨 / 砂磨

Sawing
Gergaji
锯切

Planing / Routing
Pengisar / Tenggang
刨削 / 雕刻

Others
Lain-lain
其他

Outdoor Power Equipment
Alatan Kuasa Luar
园具 / 户外

Makita
MAKITA

For Cleaning



Model
DVC350 / DVC860L /
DVC862L / DVC863L



Model
DVC261 / DVC265

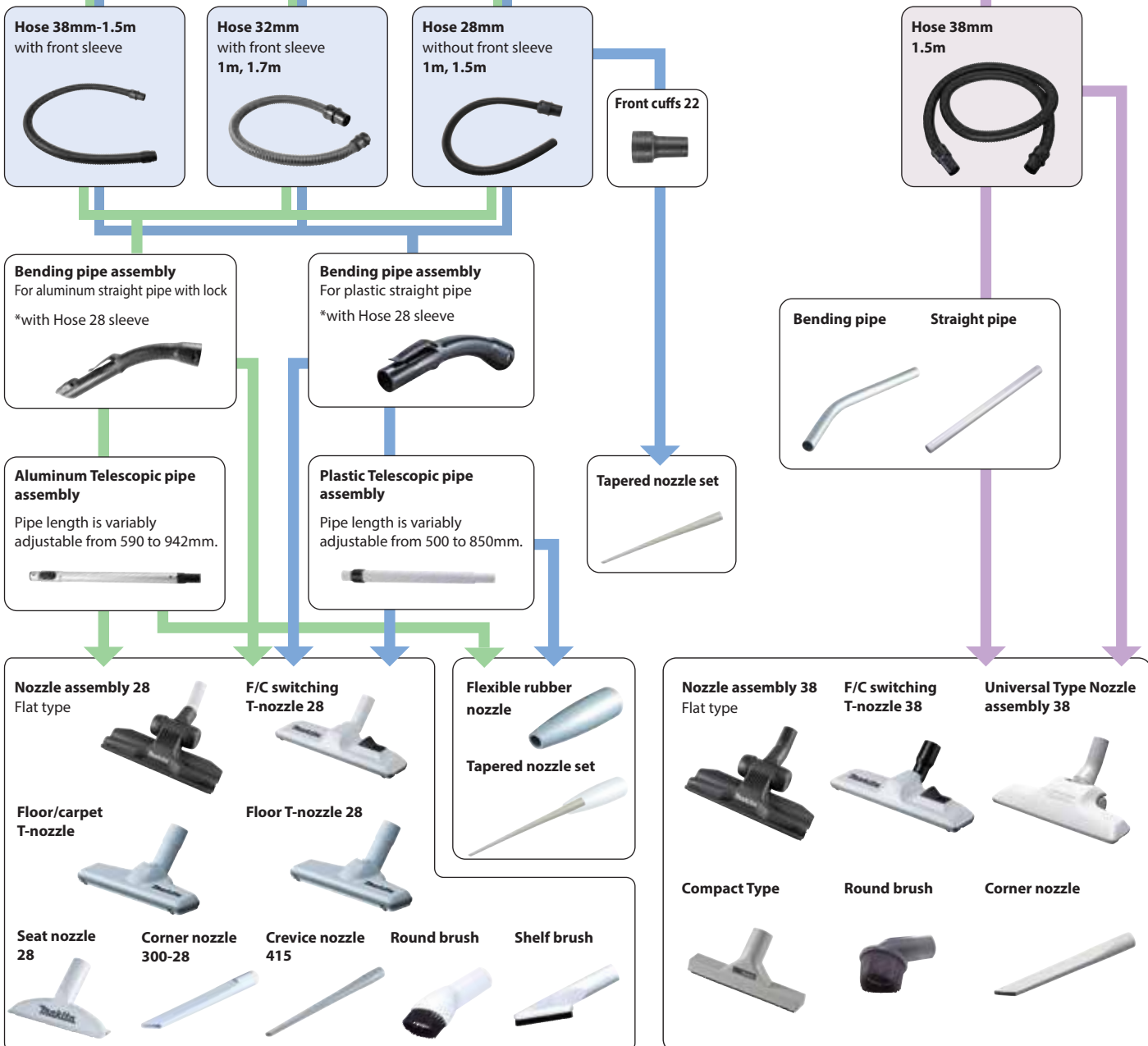

Cordless
Tapekord ไร้สาย

LED Flashlight
Lampu Suluh LED
LED 3000lm

Vacuum Cleaner
Pembersih Vakuum
ดูดฝุ่น

Drilling / Fastening
Gergaji / Pengikat
bor / mur

Impact Drilling / Demolition
Gergaji / Perusak
bor / pemukul

Cutting
Pemotong
cutter

Grinding / Sanding
Pengkilan / Pasir
kilang / pasir

Sawing
Gergaji
bor

Planing / Routing
Pengkilan / Tonggolan
bor / bor

Others
Lain-lain
lain

Outdoor Power Equipment
Alat-alat Tenaga Luar
alat tenaga luar



Cordless
Turret Head 角磨机

LED Flashlight
Lampu Senter LED
LED 手电筒

Vacuum Cleaner
Penyedot Vakum
吸尘器

Drilling / Fastening
Gardu / Pengikat
钻 / 紧固

Impact Drilling / Demolition
Gardu / Perusak
冲击钻 / 拆除加工

Cutting
Pemotong
切割

Grinding / Sanding
Pengkilan / Pasiran
打磨 / 砂磨

Sawing
Gergaji
锯切

Planing / Routing
Pengaliran / Tenggeran
刨削 / 雕刻

Others
Lain-lain
其他

Outdoor Power Equipment
Alat-alat Listrik
园林电工具

Makita
マキタ

Cordless Cleaner System charts

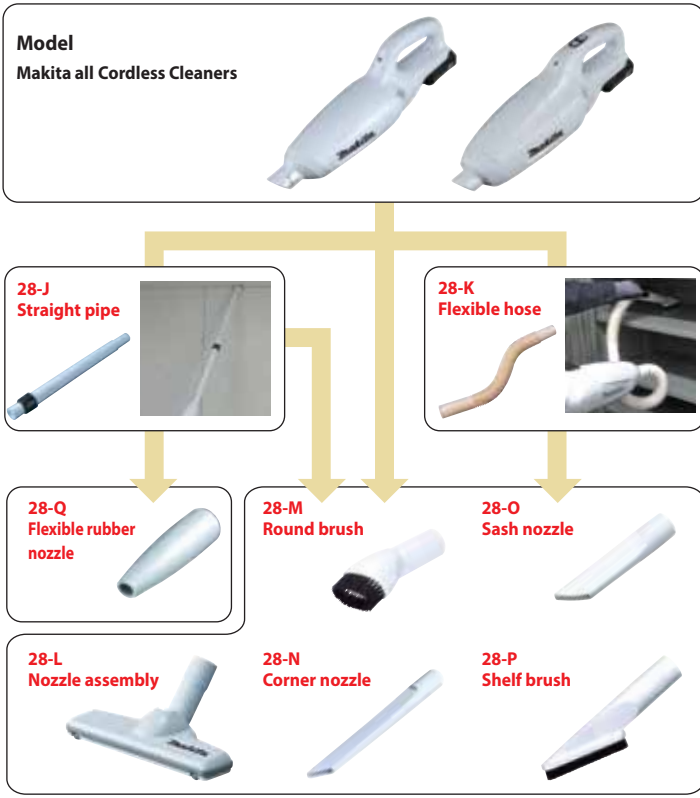

For Cordless Cleaner 28-J Straight pipe



Description	Color	Part No.
Aluminum Telescopic pipe assembly Pipe length is variably adjustable from 590 to 942mm.	Aluminum	140G19-0
Telescopic pipe assembly 28 Pipe length is variably adjustable from 500 to 850mm.	White	198560-5
Plastic straight pipe 28	Ivory	451424-7
	White	451241-5
	Blue	451244-9
	Red	451425-5
	Black	456587-4

28-K Flexible hose set28



Description	Color	Part No.
Flexible hose set28 Superior in flexibility and for the cleaning of the small place in the car	Ivory	191496-7
	White	198868-7
	Blue	198541-9
	Red	198542-7
	Pink	198871-8
	Black	198547-7

For Dust Collecting

<p>W/ Ø28mm Hose Model DVC350 / DVC863L / DVC864L</p>	<p>W/ Ø38mm Hose Model DVC860L / DVC862L / DVC863L / DVC750L</p>	<p>W/ Ø28mm Hose Model DVC261 / DVC265</p>
<p>W/ Front cuffs</p> <p>38 24 22</p>	<p>W/ Joint 22-38</p>	<p>W/ Front cuffs</p> <p>38 24 22</p>

Attachments



28-L Nozzle assembly

Flat type



F/C switching t-nozzle 28



Description	Color	Part No.	EU
			Part No.
F/C switching t-nozzle 28 Flooring & carpet	White	198183-9	198532-0
F/C switching t-nozzle 28 Flooring & carpet	Blue	199431-9	-

Nozzle assembly

For rug / carpet cleaning



Description	Color	Part No.
For rug / carpet cleaning	Ivory	122291-4

Nozzle assembly

Floor/carpet t-nozzle
For rug / carpet cleaning



Description	Color	Part No.
Floor/carpet t-nozzle For rug / carpet cleaning	Ivory	198150-4
	White	198525-7
	Blue	198523-1
	Red	198524-9
	Pink	198883-1
	Black	198526-5

Nozzle assembly

Floor t-nozzle 28



Description	Color	Part No.
Floor t-nozzle 28	Ivory	123485-4
	White	123486-2
	Blue	123488-8
	Black	123539-7
	White	122861-9
	Blue	122859-6

Nozzle assembly

Seat nozzle 28



Description	Color	Part No.
Seat nozzle 28 For car seat	White	199038-1
	Blue	199041-2
	Black	199039-9

28-M

Round brush 28



Color	Part No.
Ivory	198552-4
White	198878-4
Blue	198549-3
Red	198550-8
Pink	198880-7
Black	198551-6

28-N

Corner nozzle 330-28

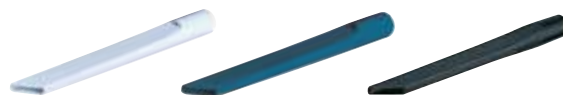

Size	Color	Part No.
330-28mm	White	198919-6
	Blue	198990-0
	Black	198992-6

28-O

Sash nozzle 28 and Long Sash nozzle 415

Sash nozzle 28



Long Sash nozzle 415



Description	Color	Part No.
Sash nozzle 28	Ivory	416041-0
	White	451240-7
	Blue	451243-1
	Red	-
	Pink	-
	Black	456586-6
Crevice nozzle 415 set	White	199439-3

28-P

Shelf brush set 28

(For gentle cleaning by soft-tipped brush)



Color	Part No.	EU
		Part No.
Ivory	191724-0	198537-0
White	198872-6	198873-4
Blue	198534-6	-
Red	198535-4	-
Pink	198875-0	-
Black	198536-2	-

28-Q

Flexible rubber nozzle



Color	Part No.	EU
		Part No.
grey	197900-4	197901-2

28-I

Tapered nozzle set

Use with Front cutts 22 or Flexible rubber nozzle



Color	Part No.
grey	192236-6

Cordless
Tapeki Kord 10.8V

LED Flashlight
Lampu Saku LED
LED030B03

Vacuum Cleaner
Pembersih Vakuum
V1313A

Drilling / Fastening
Gardu / Pengikat
M12 / M16

Impact Drilling / Demolition
Gardu / Perusak
Beton / Bata / Gypsum

Cutting
Pemotong
U-100

Grinding / Sanding
Pemoles / Pasir
Bata / Beton

Sawing
Gergaji
M10

Planing / Routers
Pemoles / Trogam
Bata / Beton

Others
Lain-lain
M10

Outdoor Power Equipment
Alat-alat Kerdil Luar
M10-M12

Makita
1911E

Cordless
Turret Head Style

LED Flashlight
Lampu Senter LED
LED照灯

Vacuum Cleaner
Penyerap Vakum
吸尘器

Drilling / Fastening
Ganda / Pasak
钻杆 / 螺柱

Impact Drilling / Demolition
Ganda / Perusak
钻杆 / 拆墙工具

Cutting
Pemotong
切割机

Grinding / Sanding
Pengkilan / Pasiran
打磨 / 砂磨

Sawing
Gergaji
电锯

Planing / Routing
Pengaliran / Tenggeran
刨削 / 雕刻

Others
Lain-lain
其他

Outdoor Power Equipment
Alat-alat Listrik
园机 / 户外

Makita
Makita

Hose



Description	Size	Part No.
without front sleeve	28mm-1m	143787-2

Bending pipe assembly

*with Hose 28 sleeve



Description	Part No.
For Aluminum Telescopic pipe assembly with lock	*127093-3
Bent pipe assembly for DVC260	123677-5

For CL121D

Mat nozzle 120



Seat nozzle 120 complete



Rubber nozzle 330



Soft brush 360 complete



Description	Part No.
Mat nozzle 120	459056-4
Seat nozzle 120 complete	140H95-0
Rubber nozzle 330	422437-5
Soft brush 360 complete	140H94-2

**For DVC350
Dust bag**



Part No.
122918-6

Flexible hose set
(Total length: 95cm)



Model No.	Part No.
DUB182, UB1100, UB1101	191750-9

For DRC200



Description	Part No.
Boundary line tape (15m roll)	SH00000240 (USA, AU)
Side brushes	SH00000065
Power brush	SH00000063
Turn brush cover	SH00000064
Filter	SH00000213

Nozzle assembly



Model No.	Size(mm)	Part No.
DVC350	220	132025-7
	430	134182-7

Quick charger
(AC only)



Model No.	Charging time (min.) (approx.)	Part No.
CL104D, CL105D, CL111D	180	DC1001 / 196832-2

For DCL501



	Type	Part No.
Hose	-	SH00000034
Straight pipe	Adjustable length	SH00000060
Nozzle assembly	Flooring & carpet	SH00000058
Crevice nozzle	-	SH00000042

Holder set



Model No.	Part No.
CL001G, DCL280F, DCL281F, DCL282F, DCL180, DCL181F, DCL182, CL114FD, CL107FD	199971-7

Backpack Vacuum Cleaner Model: DVC660, DVC665, DVC260, DVC261, DVC265

DVC660, DVC665

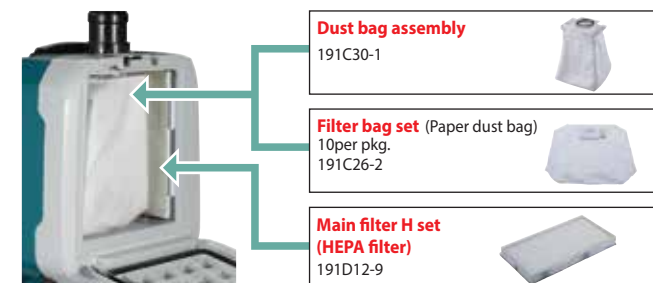

Dust bag assembly 191C30-1	
Filter bag set (Paper dust bag) 10per pkg. 191C26-2	
Main filter H set (HEPA filter) 191D12-9	

DVC260, DVC261, DVC265

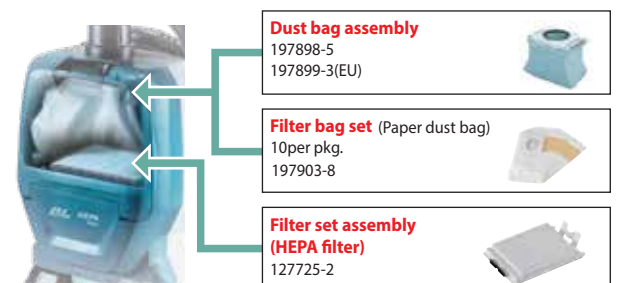

Dust bag assembly 197898-5 197899-3(EU)	
Filter bag set (Paper dust bag) 10per pkg. 197903-8	
Filter set assembly (HEPA filter) 127725-2	

Capsule type cleaner Model: CL001, GDCL281F, DCL280F, DCL181F, DCL180F, DCL180, CL183D, CL108FD, CL106FD, CL070D

HEPA filter H set
199989-8
Except Model: CL183D

HEPA filter + Pre filter

HEPA filter + Easy shake off filter B set

Filter + Pre filter

Filter
10per pkg
198915-4

Pre filter
198750-0
198751-8 (EU)

Easy shake off filter B set
199966-0

Easy shake off dust filter
455176-2

Stay (Filter flame)
458467-0

Sponge sheet 57
422268-2
Except Model: CL070D, CL183D

Valve
424208-6

Paper bag type cleaner Model: CL002G, DCL282F, DCL182, DCL182F, CL114FD, CL121D, CL107FD, CL072D, DCL184, CL121D

Sponge sheet 76-110
(Recessed wall)
424804-0

Guard
413J77-0
CL002G only

Paper filter Anti-bacterial type
(High performance filter)
10per pkg. 194565-3
5per pkg. 194566-1

Dust bag
198746-1

Easy shake off dust bag
198748-7
Except Model: CL002G

High performance dust bag
1910M4-5
For CL002G only

Valve stay complete (Dust stopper)
143677-9
DCL184, DCL182, DCL182F,
CL114FD, CL121D, CL107FD,
CL072D
140K23-3
CL002G, DCL282F

Sponge sheet 90
422440-6

Cordless Upright Cleaner Model: DVC560

28mm Tip attachments

Seat nozzle 28
For automobile
○ 199038-1
● 199041-2
● 199039-9

Long sash nozzle 330
○ 198919-6
○ 198990-0
● 198992-6
● 191D65-8

Seat nozzle 120 set
For automobile
140H95-0

Long Sash nozzle 415
○ 199439-3

Mat nozzle 120
For automobile
459056-4

Round brush
● 198552-4
○ 198878-4
● 198549-3 / 198553-2
● 198551-6 / 198555-8
● 191D67-4

Brush nozzle set
191M30-1

Shelf brush
● 198537-0
○ 198873-4
● 198534-6 / 198538-8
● 198536-2 / 198540-1

Sash nozzle
● 416041-0
○ 451240-7
○ 451243-1
● 456586-6
○ 413770-6
● 413809-5

Soft brush 360 complete set
140H94-2

Filter bag set
10pcs. set
191T96-3

Main filter h set HEPA filter
191E39-5

Brush complete set
191D69-0 / 1910T8-6

Cordless
Tampol Kordless

LED Flashlight
Lampu Saku LED
LED03803

Vacuum Cleaner
Pembersih Vakuum
真空吸尘器

Drilling / Fastening
Gergaji / Pengikat
电钻 / 紧固件

Impact Drilling / Demolition
Gergaji / Perusak
电锤 / 拆除工具

Cutting
Pemotong
切割机

Grinding / Sanding
Pemoles / Pasir
砂磨机 / 砂纸

Sawing
Gergaji
电锯

Planing / Routing
Pencapaian / Tumpang
刨床 / 榫槽

Others
Lain-lain
其他

Outdoor Power Equipment
Alat-alat Listrik
户外电源设备

Makita
MAKITA

VACUUM CLEANER

Automatic Self-cleaning Filtration System achieved by two filter units

Sistem Penapis Penyucian Automatik 自动清洗过滤系统

Constantly high suction power throughout operation because dust is removed from Prefilters every 10 seconds during operation

Kuasa penyedut yang berterusan sepanjang operasi kerana habuk dikeluarkan dari penapis setiap 10 saat semasa operasi
在整个运行过程中吸力保持在较高的水平,因为在运行过程中,每10秒就会从过滤器中除去灰尘

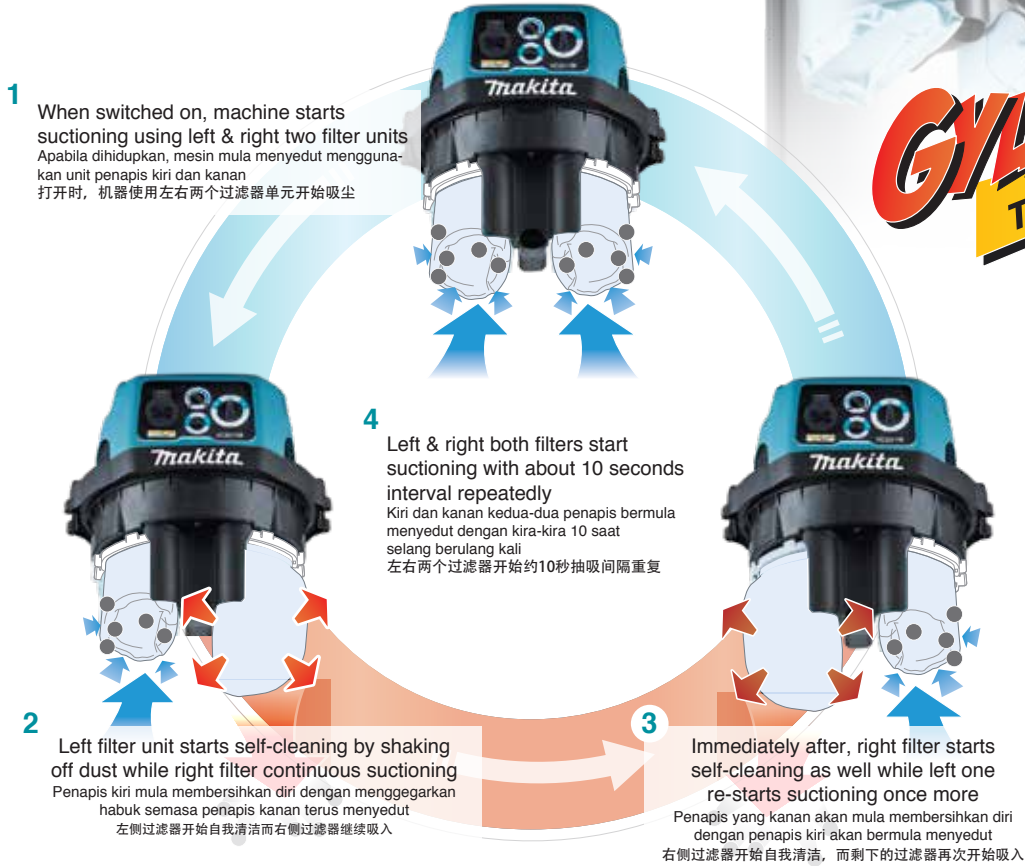

VC3211M

Vacuum Cleaner (Wet & Dry)
Pembersih Vakum (Basah Dan Kering)
吸尘器(干湿两用)

- 32L Large dust bag capacity enables continuous cleaning work
Kapasiti debu 32L besar boleh membersihkan secara berterusan
32L大容量尘袋可延续清洁工作

Standard Equipment: Hose, Holder 10-33, Front Cuffs (22, 24, 38), Cloth Filter, Poly Bag Set 10pcs



AUTOMATIC Self-cleaning Filtration System
Sistem Penapis Penyucian Automatik
自动清洗过滤系统

Continuous Rating Input Kuasa Sedutan 额定输入功率	1,050W
Max Peak Air Flow Aliran Udara 最大空气流量	2.0m ³ /min
Max Sealed Suction (water column) Sedutan Terkedap (Turus Air) 最大密封吸力(水柱)	22.0kPa (2,240 mmH ₂ O)
Tank Capacity Kapasiti 容量	Dust: 32L Water: 27L
Dimensions (L x W x H) Dimensi 体积	552x398x685mm
Net Weight Berat Bersih 净重	16.9kg (37.3lbs)
Power Supply Cord Kabel Wayar 电源线	5.0m (16.4ft)

VC2211M

Vacuum Cleaner (Wet & Dry)
Pembersih Vakum (Basah Dan Kering)
吸尘器(干湿两用)

- Approved for Dust Class M in accordance with the EU standard
Diluluskan oleh piawaian EU untuk menyedut debu kelas M
依欧盟标准, 集尘等级M

Standard Equipment: Hose, Front Cuffs (22, 24, 38), Belt Hook, Hose Band, Cap, Poly bag 800x650, Poly Bag Set 10 pcs



AUTOMATIC Self-cleaning Filtration System
Sistem Penapis Penyucian Automatik
自动清洗过滤系统

Continuous Rating Input Kuasa Sedutan 额定输入功率	1,050W
Max Peak Air Flow Aliran Udara 最大空气流量	2.0m ³ /min
Max Sealed Suction (water column) Sedutan Terkedap (Turus Air) 最大密封吸力(水柱)	22.0kPa (2,240 mmH ₂ O)
Tank Capacity Kapasiti 容量	Dust: 22L Water: 17L
Dimensions (L x W x H) Dimensi 体积	552x398x569mm (21-3/4"x15-5/8"x22-3/8")
Net Weight Berat Bersih 净重	16.3kg (35.9lbs)
Power Supply Cord Kabel Wayar 电源线	5.0m (16.4ft)

Cordless
Tandas Kordless

LED Flashlight
Lampu Boleh LED
LED 照明灯

Vacuum Cleaner
Pembersih Vakum

Drilling / Fastening
Drobul / Pengikat
钻孔 / 紧固

Impact Drilling / Demolition
Drobul / Pencah
冲击钻孔 / 拆除加工

Cutting
Pemotongan

Grinding / Sanding
Pengamir / Pasukan
打磨 / 砂磨

Sawing
Gergaji

Planing / Routing
Pengamir / Tengking
刨削 / 雕刻

Others
Lain-lain
其他

Outdoor Power Equipment
Alatan Kuasa Luar
园具 / 户外

Makita
1915

VACUUM CLEANER

Automatic self-cleaning filter (VC1310L, VC2510L, VC3210L)

Sistem Penapis Penyucian Automatik 自动清洗过滤器系统

obtained by Triple filter structure composed of: Powder filter + Damper + Prefilter
 Kuasa penyedutan yang berkesan sepanjang operasi kerana habuk dikeluarkan dari Prefilters setiap 10 saat semasa operasi
 由三重过滤器结构得到: 粉末过滤器+阻尼器+预过滤器

When the power is switched on, Prefilter collapses into itself to compress Damper, and fits closely over Damper and Powder filter.

Apabila kuasa dihidupkan, Prefilter runtuh ke dalamnya untuk memampatkan Damper, dan sesuai dengan penapis Damper dan Serbuk. 当接通电源时, Prefilter会自行折叠以压缩阻尼器, 并紧密贴合阻尼器和粉末过滤器。

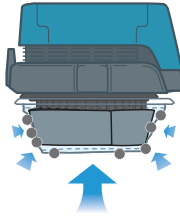

When the power is switched off, Damper expands back to its original size and shakes off dust from Prefilter automatically with its expanding power.

Apabila kuasa dimatikan, Damper mengembang kembali ke saiz asalnya dan mengelakkan habuk dari Prefilter secara automatik dengan kuasa yang berembang. 当电源关闭时, 阻尼器膨胀回到其原始尺寸, 并通过扩展的功率自动将Prefilter的灰尘抖落。

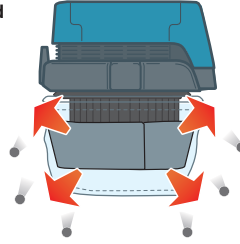

VC3210L

173 W

Vacuum Cleaner (Wet & Dry)
 Pembersih Vakum (Basah Dan Kering)
 吸尘器(干湿两用)



Dust Class L
 Debu Kelas L | 集尘等级 L
WET Basah 湿
DRY Kering 干

- For both wet and dry vacuum cleaning untuk menyedut kotoran kering atau lembap 适用于干和湿集尘清洁

Standard Equipment: Hose, Holder 10-33, Front Cuffs (22, 24, 38), Cloth Filter, Damper, Poly Bag Set (10pcs)



Continuous Rating Input Kuasa Sedutan 额定输入功率	1,050W
Max Peak Air Flow Aliran Udara 最大空气流量	2.0m ³ /min
Max Sealed Suction (water column) Sedutan Terkedap (Turus Air) 最大密封吸力(水柱)	22.0kPa (2,240 mmH ₂ O)
Tank Capacity Kapasiti 容量	Dust: 32L Water: 27L
Dimensions (L x W x H) Dimensi 体积	552x398x685mm (21-3/4"x15-5/8"x27")
Net Weight Berat Bersih 净重	14.5kg (32.0lbs)
Power Supply Cord Kabel Wayar 电源线	5.0m (16.4ft)

VC2510L

173 W

Vacuum Cleaner (Wet & Dry)
 Pembersih Vakum (Basah Dan Kering)
 吸尘器(干湿两用)



Dust Class L
 Debu Kelas L | 集尘等级 L
WET Basah 湿
DRY Kering 干

- For both wet and dry vacuum cleaning untuk menyedut samaada kotoran kering atau lembap 适用于干和湿集尘清洁

Standard Equipment: Hose, Holder 10-33, Front Cuffs (22, 24, 38), Poly Bag, Poly Bag Set (10pcs)



Continuous Rating Input Kuasa Sedutan 额定输入功率	1,050W
Max Peak Air Flow Aliran Udara 最大空气流量	2.0m ³ /min
Max Sealed Suction (water column) Sedutan Terkedap (Turus Air) 最大密封吸力(水柱)	22.0kPa (2,240 mmH ₂ O)
Tank Capacity Kapasiti 容量	Dust: 25L Water: 14L
Dimensions (L x W x H) Dimensi 体积	432x416x451mm (17"x16-3/8"x17-3/4")
Net Weight Berat Bersih 净重	10.5kg (23.2lbs)
Power Supply Cord Kabel Wayar 电源线	5.0m (16.4ft)

VC1310LX1

173 W

Vacuum Cleaner (Wet & Dry)
 Pembersih Vakum (Basah Dan Kering)
 吸尘器(干湿两用)



Dust Class L
 Debu Kelas L | 集尘等级 L
WET Basah 湿
DRY Kering 干

- For both wet and dry vacuum cleaning untuk menyedut samaada kotoran kering atau lembap 适用于干和湿集尘清洁

Standard Equipment: Hose, Holder 10-33, Front Cuffs (22, 24, 38), Poly Bag Set, Cleaning Set



Continuous Rating Input Kuasa Sedutan 额定输入功率	1,050W
Max Peak Air Flow Aliran Udara 最大空气流量	2.0m ³ /min
Max Sealed Suction (water column) Sedutan Terkedap (Turus Air) 最大密封吸力(水柱)	22.0kPa (2,240 mmH ₂ O)
Tank Capacity Kapasiti 容量	Dust: 13L Water: 7L
Dimensions (L x W x H) Dimensi 体积	366x334x420mm (14-3/8"x13-1/8"x16-1/2")
Net Weight Berat Bersih 净重	9.6kg (21.2lbs)
Power Supply Cord Kabel Wayar 电源线	5.0m (16.4ft)

VC2000L

Vacuum Cleaner (Wet & Dry)
 Pembersih Vakum (Basah Dan Kering)
 吸尘器(干湿两用)

- For both wet and dry vacuum cleaning untuk menyedut kotoran kering atau lembap 适用于干和湿集尘清洁

Standard Equipment: 3.5m x 32mm Hose, Heavy Duty PET Filter, Cloth Bag, Poly Bag Set, Hose Band, Floor Nozzle, Universal Nozzle, Crevice Nozzle, Straight Pipe x2



Dust Class L
 Debu Kelas L | 集尘等级 L
WET Basah 湿
DRY Kering 干



Continuous Rating Input Kuasa Sedutan 额定输入功率	1,000W
Capacity Kapasiti 尘袋容量	Dust: 20L Water: 13L
Max Air Flow Aliran Udara 最大空气流量	3.6m ³ /min
Max Sealed Suction Sedutan Terkedap 最大密封吸力	21kPa
Net Weight Berat Bersih 净重	7.5kg

Cordless Tempak Kord 无线电
 LED Flashlight Lampu Suluh LED LED 闪光灯
 Vacuum Cleaner Pembersih Vakum 吸尘器
 Drilling / Fastening Cetus / Pengikat 钻孔 / 紧固
 Impact Drilling / Demolition Cetus / Pencah 冲击钻孔 / 拆除
 Cutting / Penjurian 切割
 Grinding / Sanding Pengkilan / Palsan 研磨 / 打磨
 Sawing / Gergaji 锯切
 Planing / Routing Penyucian / Tunggam 刨削 / 雕刻
 Others Lain-lain 其他
 Outdoor Power Equipment Alatan Kuasa Luar 户外动力设备
Makita
 THE POWER OF PRO

Vacuum Cleaner System charts

Hose connection
28mm

Hose connection
38mm

Hose connection
32mm

For Cleaning

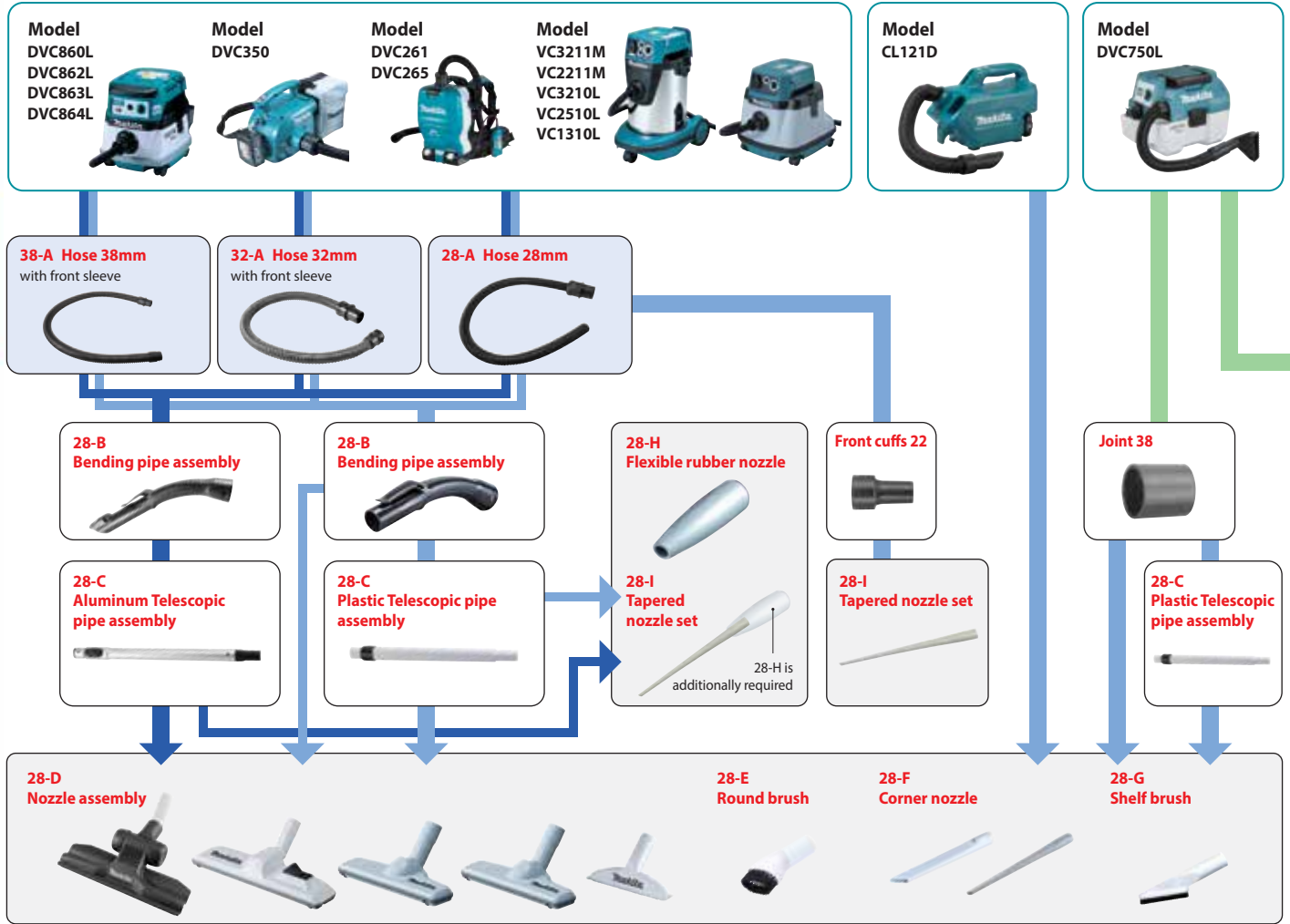

For Dust Collecting

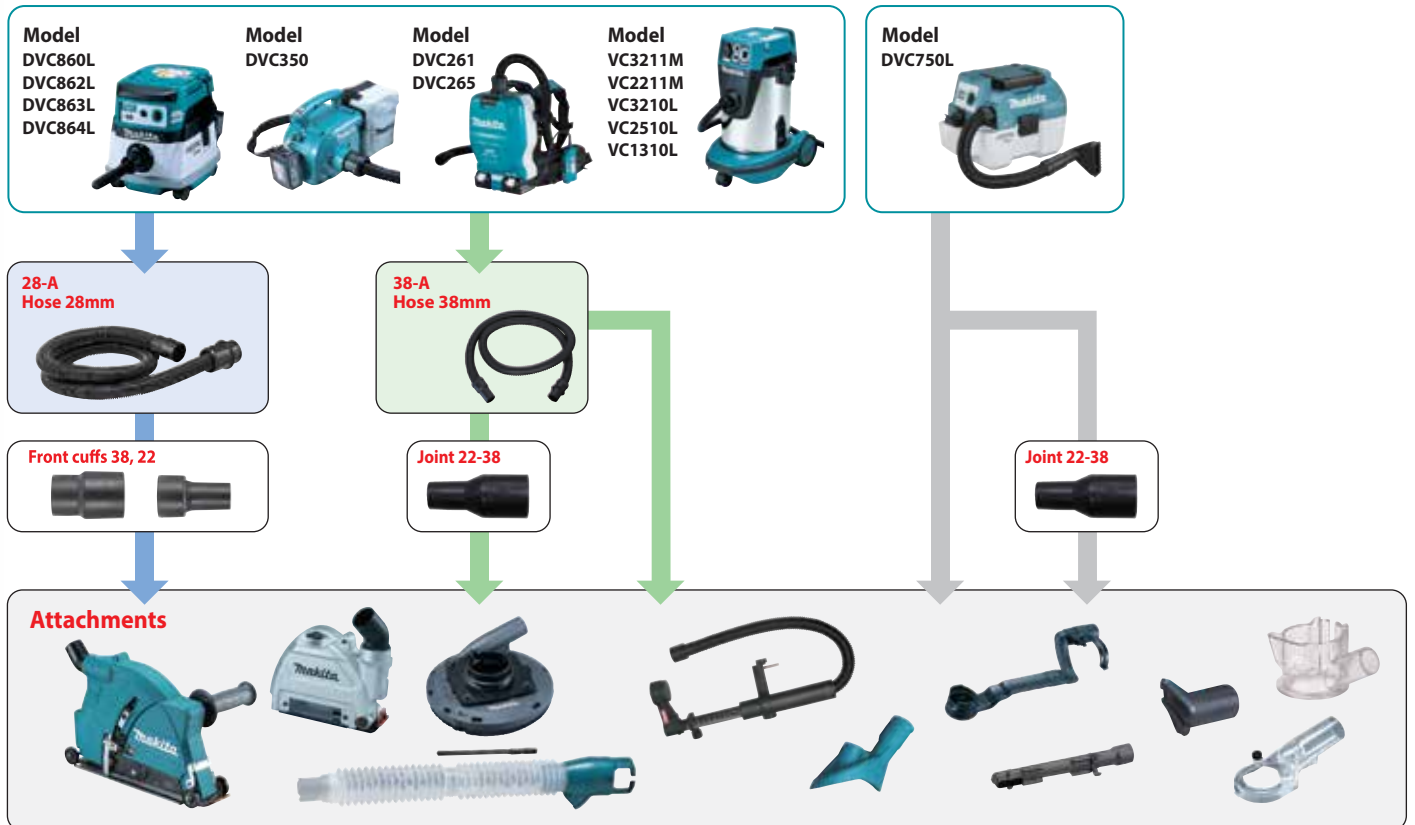

Cordless
Tanpa Kabel Listrik

LED Flashlight
Lampu Senter LED
LED 照灯

Vacuum Cleaner
Penyerap Vakum
吸尘器

Drilling | Fastening
Drobul | Pengikat
钻孔 | 紧固

Impact Drilling | Demolition
Drobul | Perusak
冲击钻孔 | 拆除加工

Cutting
Pemotong
切割

Grinding | Sanding
Pengkilan | Pasir
打磨 | 砂磨

Sawing
Dempul
切割

Planing | Routing
Pengkilan | Tenggang
刨削 | 修边

Others
Lain-lain
其他

Outdoor Power Equipment
Alat-alat Listrik
户外电力设备

Makita
マキタ

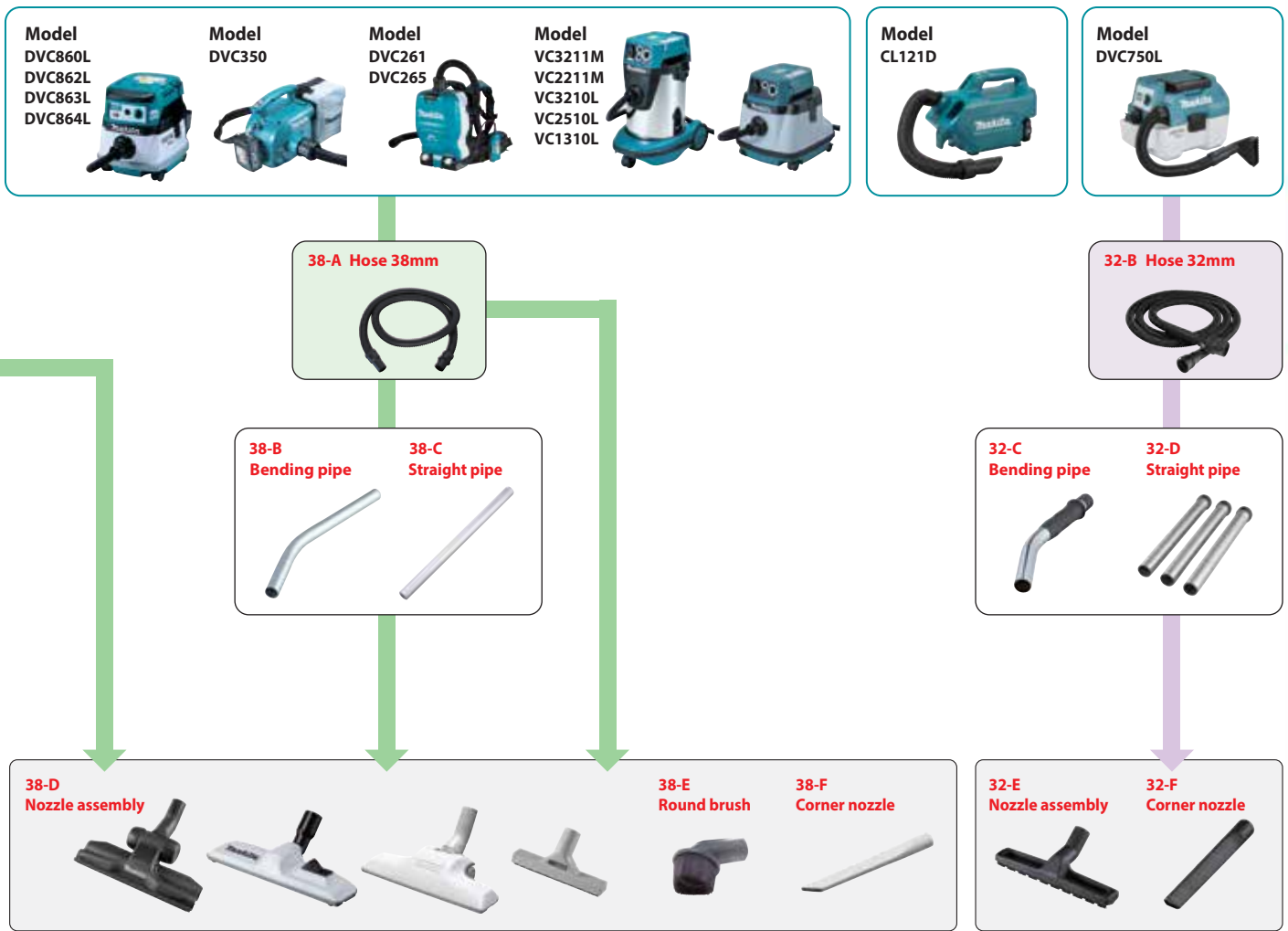

Front cuffs, Joint & Hose Connection

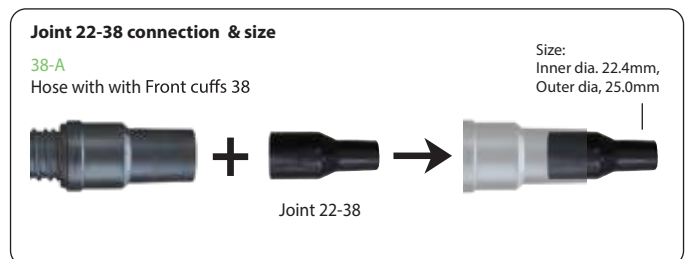
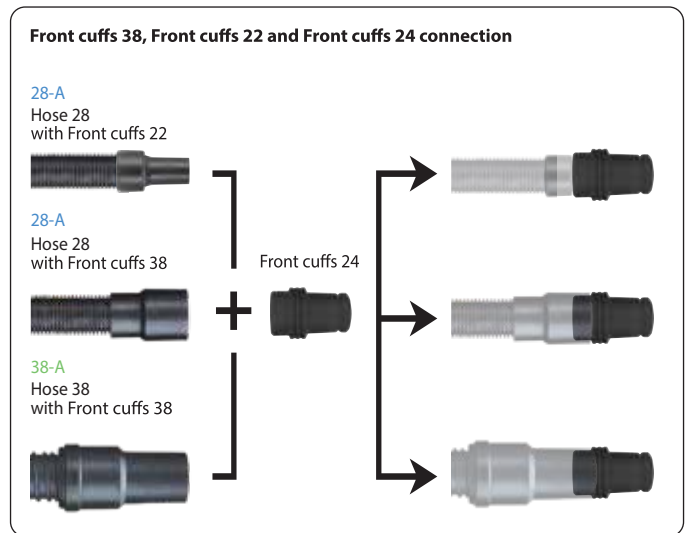
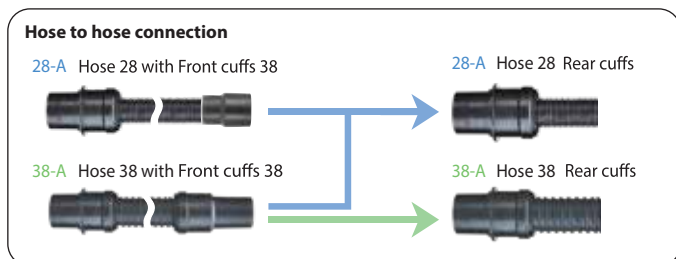
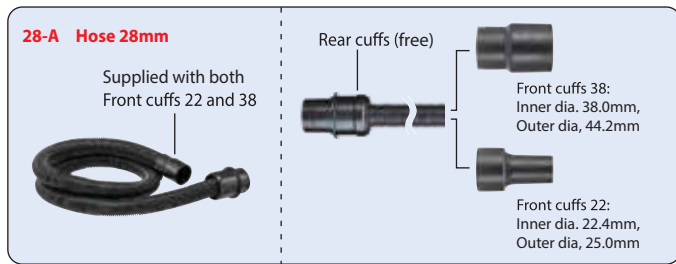

Cordless
Tapekord 10.8V

LED Flashlight
Lampu Senter LED
LED 10.8V

Vacuum Cleaner
Pembersih Vakuum
10.8V

Drilling / Fastening
Gergaji / Pengikat
10.8V

Impact Drilling / Demolition
Gergaji / Pemecok
10.8V

Cutting
Pemotong
10.8V

Grinding / Sanding
Pengkilan / Pasukan
10.8V

Sawing
Gergaji
10.8V

Planing / Routing
Pengkilan / Tenggang
10.8V

Others
Lain-lain
10.8V

Outdoor Power Equipment
Alat-alat Listrik Luar
10.8V

Makita
10.8V

Filter & Dust bag

Cordless
Turret Head 炮台式

LED Flashlight
Lampu Senter LED
LED照灯

Vacuum Cleaner
Penyedot Vakum
吸尘器

Drilling / Fastening
Gardu / Pengikat
钻孔 / 紧固

Impact Drilling / Demolition
Gardu / Perusak
钻孔 / 拆除加工

Cutting
Pemotong
切割

Grinding / Sanding
Pengkil / Pasir
打磨 / 砂磨

Sawing
Gergaji
锯切

Planing / Routing
Pengaliran / Tenggang
刨削 / 雕刻

Others
Lain-lain
其他

Outdoor Power Equipment
Alat-alat Kerja Luar
园具 / 户外

Makita
MAKITA



for Dust (Powder)

for Wet & Dry

Compatible with usual Poly bags or Paper filters, allowing for:



- Quick and easy dust disposal
- Lower-running cost compared with paper dust bag



	VC001GL	VC002GL, VC005GL	DVC865L, DVC862L, DVC860L, DVC155L, DVC152L, DVC150L	DVC867L, DVC864L, DVC863L, DVC157L, DVC154L, DVC153L, DVC151L	VC3211M, VC2211M	VC3210L	VC2510L	VC1310L
	(Wet & Dry)	(Dry)	(Wet & Dry)	(Dry)	(Wet & Dry)	(Wet & Dry)	(Wet & Dry)	(Wet & Dry)
Use as a set	Powder filter set Dry only	*191V70-3 		*197166-6 		195441-4 		195438-3
	*HEPA filter for Dry use only							
	Damper set	191V68-0 		195552-5 		195552-5 		
	Pre-filter set	191V69-8 		195553-3 		196253-8 		195553-3
Cloth filter Wet & Dry	144625-1 	144625-1 191V71-1 (VC005G only) 	140248-3 					
Water filter Wet only	191V67-2 							
	It is recommended using water filter when picking up large amount of water repeatedly							
Filter bag set 15L (5pcs) for dry dust					195557-5 			195557-5
Poly bag set (10pcs)			195432-5 		195440-6 		195432-5 	

To use powder filter, remove the float cage and float by removing the bolts.

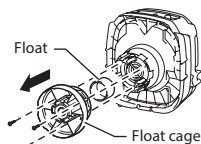

Capacity up tank set







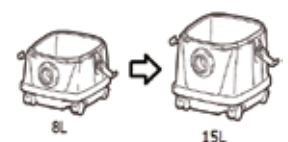

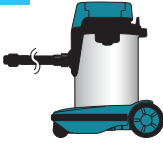

DVC860L, DVC861L, DVC865L, DVC866L, DVC867L

191B56-7, 191B57-5*



* "HEPA filter" Mark on tank







System charts

<p>A</p>  <p>W/ Ø28mm Hose</p> <p>Model VC3211M VC2211M VC3210L</p> <p>W/ Front cuffs</p>  <p>38 24 22</p>	<p>B</p>  <p>W/ Ø28mm Hose</p> <p>Model VC2510L VC1310L DVC863L DVC864L</p> <p>W/ Front cuffs</p>  <p>38 24 22</p>	<p>C</p>  <p>W/ Ø28mm Hose</p> <p>Model DVC350</p> <p>W/ Front cuffs</p>  <p>38 24 22</p>	<p>D</p>  <p>W/ Ø38mm Hose</p> <p>Model DVC860L DVC862L DVC863L DVC750L</p> <p>W/ Joint 22-38</p> 	<p>E</p>  <p>W/ Ø28mm Hose</p> <p>Model DVC261 DVC265</p> <p>W/ Front cuffs</p>  <p>38 24 22</p>
---	---	--	---	---

For Model | **Suction Systems and Part No.**

<p>Rotary Hammer, Demolition Hammer SDS-MAX, 17mm (11/16") Hex: Bull points with over 280mm length Cold chisels with over 280mm length</p> <p>SDS-MAX only: Scaling chisel (for tile), Bushing tool Scaling chisels length</p> <p>19mm (3/4") Hex only Scaling chisels</p> <p>17mm (11/16") Hex: HM0830, HR3530, HR4030C</p> <p>SDS-MAX: HR4001C/02/10C/11C, HR4501C/10C/11C, HR3540C/41FC HM0870C/71C, HM1101C/11C, HM1203C/13C, HM1214C HR4501C/10C/11C, HR4013C HR4003C, HR3540C/41FC DHR400, HR5202C, HR5212C, HM1205</p> <p>19mm (3/4") Hex: HR4041C</p>	<p>Dust extractor attachment set (Hammering mode only) 199144-2 (w/hose for) 199143-4 (w/o hose for)</p>  <p>ø28mm hose can be directly connected.</p>	<p>Electric Breaker HM1304/B, HM1306, HM1317C/CB, HM1307C/CB, HM1400, HM1500/B, HM1810, HM1801, HM1812, HM1802</p>  <p>197168-2 (w/o hose for) 197148-8 (w/ hose for)</p> <p>ø28mm hose can be directly connected.</p>	<p>Vacuum attachment set</p>  <p>197168-2 (w/o hose for) 197148-8 (w/ hose for)</p> <p>ø28mm hose can be directly connected.</p>	<p>A Directly</p> <p>B Directly</p> <p>C Directly</p> <p>D ø28mm hose</p> <p>E Directly</p>
---	---	--	--	--

For Model | **Suction Systems and Part No.**

<p>Rotary Hammer, Combination Hammer see page 150</p> <p>DHR242, HR2650, HR2651, HR2652, HR2653, HR2661, HR2663, DHR280, DHR282, HR2300, HR2600, HR2601, HR2601F, HR2630, HR2631F, HR2641 DHR243, HR2651T, HR2653T, —195179-1 HR2300T, HR2320T, HR2630T, HR2631FT,</p> <p>DHR164, DHR165, DHR171, —198362-9 DHR182, HR140D, HR166D, HR1840, HR1841F, HR2800, HR2810, HR2811F, DHR202, DHR241, DHR263, HR2230, HR2460, HR2460F, HR2470, HR2475</p> <p>Rotary Hammer, Combination Hammer DHR164, DHR165 DHR202, BHR262/T DHR263, DHR264</p> <p>HR2470 series HR2800 series</p> <p>Rotary Hammer HR4002, HR4011C, —195866-2 HR4010C, HR4001C, HR4511C, HR4510C, HR4501C</p> <p>HR400, HR4013C, HR4003C —199142-6 HR5212C, HR5202C —196858-4</p>	<p>Dust cup set 195173-3</p>  <p>195179-1</p>  <p>198362-9</p>  <p>193472-7</p>  <p>(Max. Bit Diameter 40mm)</p> 	<p>A Front cuffs 22</p> <p>B Front cuffs 22</p> <p>C Front cuffs 22</p> <p>D Joint 22-38 195548-6</p> <p>E Front cuffs 22</p>
---	--	--

Cordless
Tegak Kord 10.8V

LED Flashlight
Lampu Saku LED
LED03B03

Vacuum Cleaner
Pembersih Vakuum
195143

Drilling / Fastening
Gubris / Pengikat
HR11 / HR12

Impact Drilling / Demolition
Gubris / Pemecah
HR13M / HR13M-1

Cutting
Pemotong
HR14

Grinding / Sanding
Pengecilan / Pasukan
HR15 / HR16

Sawing
Gergaji
HR17

Planing / Routing
Pencapaian / Tenggang
HR18 / HR19

Others
Lain-lain
HR20

Outdoor Power Equipment
Alat-alat Kerdil Luar
HR21-25

Makita
1919

System charts

Cordless
Turret Head 角磨机

LED Flashlight
Lampu Senter LED
LED 照明灯

Vacuum Cleaner
Penyerap Vakum
吸尘器

Drilling / Fastening
Gardu / Pengikat
钻孔 / 紧固

Impact Drilling / Demolition
Gardu / Perusak
冲击钻孔 / 拆除加工

Cutting
Pemotong
切割

Grinding / Sanding
Pengkilan / Pasir
打磨 / 砂磨













Sawing
Gergaji
锯切





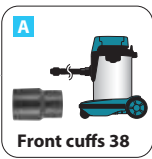
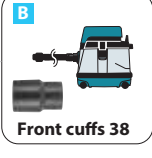









Planing / Routering
Pengaliran / Tenggang
刨削 / 雕刻

Others
Lain-lain
其他

Outdoor Power Equipment
Alat-alat Listrik
户外动力设备















Makita
Makita

For Model	Suction Systems and Part No.
Angle Cutter 4112H 4112HS 4114 4114S 	Elbow joint 32 192613-2 
Dustless Cutter 4105KB 	Elbow joint 32 192613-2 
Dustless Cutter 4100KB 	
Cutter With Dust Collection 4157KB 	
Wall Chaser SG1251, SG1250 	
Concrete Planer PC5000C, PC5001C PC5010C 	
Angle Grinder For 115, 125mm Model Single notch ——— w/o mark of origin 195237-3 Triple notches w/o mark of origin for IEC 195239-9 w/ mark of origin for IEC 195238-1 North America package 195236-5 North America package for UL 196575-6 For 180,230mm Model w/ mark of origin for IEC 195384-0 w/o mark of origin for IEC 195385-8 North America package for UL 197584-8 Towin notches w/ mark of origin 195387-4 w/o mark of origin 195388-2 North America package 195386-6	 Front cuffs 38  Front cuffs 38  Front cuffs 38  Front cuffs 38  Front cuffs 38

















For Model	Suction Systems and Part No.
Angle Grinder For 125mm Model ——— 196845-3 196846-1 	Dust collecting wheel guard 
For 230mm Model ——— 198379-2 198380-7 	
Angle Grinder For 115, 125mm Model ——— 192968-5 193794-5 (Economy type) For 180mm Model ——— 194303-3 For 230mm Model ——— 194044-1 	Dust collecting wheel guard 
Belt Sander 9924DB 	Joint 32 192518-6 
Belt Sander 9404, 9902, 9903, 9910, 9911, 9920, 	 Front cuffs 38
Belt Sander 9403, 9921 	Joint 32 192349-3 
Wheel Sander 9741 	Joint 410899-9 

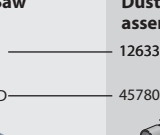

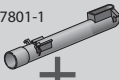
System charts

For Model	Suction Systems and Part No.
Disc Grinder N9500N, 9500NB 	Dust collecting wheel guard 192212-0  Rubber sleeve 192202-3
Angle Grinder For 100mm Model	Dust collecting wheel guard Dust collecting 100C set — 198413-8 Dust collecting 100CD set — 198414-6 
For 115,125mm Model	198415-4 
Belt Sander 9032 	Dust nozzle assembly 122652-8 
Belt Sander 9031 	
Finishing Sander 9046, BO3700, BO3710, BO3711, BO4900/V, BO4901, BO4555, BO4556, BO4565, BO4566, BO4557, BO4558 	
Random Orbit Sander BO5012, BO5030, BO5031, BO5040, BO5041, BO6030, BO6040, DBO140, DBO180 	
Multi Tool DTM50, DTM40 — 195965-0 TM3000C — 196022-7 TM3010C — 196550-2 	Dust attachment set  DTM51, DTM41 — 196765-1 
Circular Saw DHS630 — 194314-8 DSS611, DSS610 — 419283-5 DSS501, DSS500 — 194415-2 HS300D, HS301D — 195334-5 	Joint (Dust nozzle) 
Jig Saw JV100D, JV143D, JV183D 4326, 4327, 4328, 4329, JV0600 	
Jig Saw DJV140, DJV180 4350T/CT/FCT, 4351T/CT/FCT 	Dust Nozzle 417853-4 



For Model	Suction Systems and Part No.
	front cuffs24 195546-0 
Circular Saw HS6100, HS6101, HS7100, HS7101 — 453289-3 DHS710, HS6600, HS6601, HS7010, HS7600, HS7601, HS7610, HS7611 — 196520-1 HS6600, HS7000, HS7600, DHS711 — 196843-7 (with short lever) 5007N, 5007NF — 199712-1 (with short lever) HS0600 — 198263-1 DHS5680 — 198265-7 (with short lever) 196961-1 196952-2 (with short lever) HS7000, HS7600 — 196520-1 197221-4 (with short lever)	Joint (Dust nozzle) 453289-3 196520-1 196843-7 (with short lever) 199712-1 (with short lever) 198263-1 198265-7 (with short lever) 196961-1 196952-2 (with short lever) 196520-1 197221-4 (with short lever)
	Joint 22-38 195548-6 
Plunge Cut Circular Saw SP6000 	Front cuffs 24 195546-0 
Cordless Plunge Cut Circular Saw DSP600, DSP601 	
Aluminum Groove Cutter CA5000 	
Cordless Jig Saw DJV141, DJV142 — 126331-0 DJV181, DJV182 — 457801-1 DJV102D, JV103D 	Dust nozzle assembly 126331-0  457801-1  Front cuffs 24 195546-0 
Slide Compound Saw LS1019/L, LS1219/L 	Front cuffs 24 195546-0 
Cordless Slide Compound Miter Saw DLS110, DLS111, DLS112, DLS211, DLS212 	

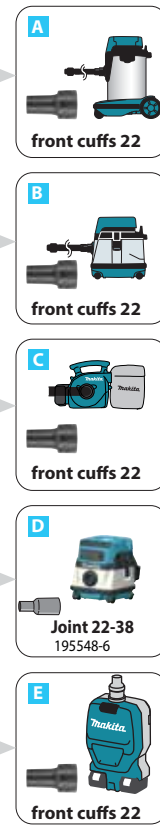

Cordless
Tenggol Kordless

LED Flashlight
Lampu Saku LED
LED38803

Vacuum Cleaner
Pembersih Vakuum
195548-6

Drilling / Fastening
Gergaji / Pengikat
HS1, HS2

Impact Drilling / Demolition
Gergaji / Perusak
HS1, HS2, HS3

Cutting
Pemotong
HS1

Grinding / Sanding
Pengkilan / Pasir
HS1, HS2

Sawing
Gergaji
HS1

Planing / Routing
Pengkilan / Tenggol
HS1, HS2

Others
Lain-lain
HS1

Outdoor Power Equipment
Alat-alat Listrik Luar Ruangan
HS1, HS2

Makita
1919

System charts

Cordless
Turret Head 炮台式

LED Flashlight
Lampu Sinar LED
LED 照明灯

Vacuum Cleaner
Pembersih Vakum
吸尘器

Drilling / Fastening
Drooi / Pengikat
钻孔 / 紧固

Impact Drilling / Demolition
Drooi / Persekol
冲击钻孔 / 拆除加工

Cutting
Pemotong
切割

Grinding / Sanding
Pengkilan / Pasiran
打磨 / 砂磨













Sawing
Drooi
锯切











Planing / Routing
Pengaliran / Ronggaman
刨削 / 雕刻

Others
Lain-lain
其他

Outdoor Power Equipment
Alatan Kerja Luar
园机 / 户外



For Model	Suction Systems and Part No.
Cordless Slide Compound Miter Saw DLS713 DLS714 	A  Front cuffs 38
Slide Compound Saw LS0714/F/FL/L LS0815F/FL LS1016L LS1017L LS1018/L LS1216/L 	B  Front cuffs 38
Miter Saw LS1030N, LS1440 	C  Front cuffs 38
Compound Miter Saw LS1040/F, LS1045, LS1221 	D 
Cordless Compound Miter Saw DLS600 	E 
Flip Over Saw LF1000 	
Table Top Miter Saw LH1040/F LH1201FL 	

For Model	Suction Systems and Part No.
Table Saw 2704N, 2705 	Joint 419093-0  Front cuffs 38
Table Saw 2703 	Joint 55 192799-2  Front cuffs 38
Table Saw MLT100N 	Dust point JM27000090 
Table Saw 2712 	E 
Band Saw LB1200F 	Joint 419093-0 



System charts

For Model	Suction Systems and Part No.
Circular Saw 5603R, 5704R, 5705R ——— 192420-3 5143R ——— 192490-2 5008MG ——— 450079-5 ——— 194489-3 (with short lever) 5103R, 5903R ——— 192419-8 5104S, 5104 ——— 450316-7 N5900B, 5902B ——— 193823-9 ——— 193068-4 (with short lever)	
Circular Saw 5604R, 5037NB	
Dustless Circular Saw 5017RKB 5057KB	

*C: DVC350 Cannot be used with Planer models

For Model	Suction Systems and Part No.
Power Planer 1050D, 1051D KP0810/C	
Power Planer DKP180, DKP140 KP0800	Nozzle 451329-1
1805N ——— JPA122277	
Power Planer 1911B	Nozzle for vacuum cleaner 192082-7
Power Planer N1900B, N1923B, KP0800, 1804N 1805N, 1806B, KP312/S	

*C: DVC350 Cannot be used with Planer models

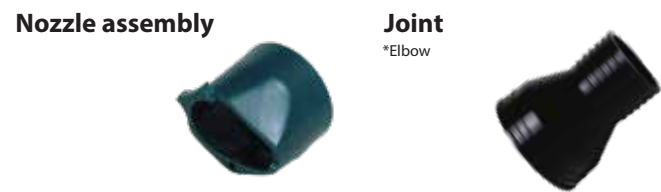

Model No.	Part No.	Model No.	Part No.
N1900B, N1923B	181572-5	N1900B, N1923B	JPA122275 (122275-2)
KP0800, DKP180, DKP140	451329-1	DKP180, DKP140, KP0810/ C, KP0800	*416368-8
1804N	JPA122278 (122278-6)	1804N, 1805N, 1806B, KP312/S	181575-9
1805N	JPA122277 (122277-6)		
1806B	122397-8		
KP312/S	193733-5		

Cordless
Tegak Kord 10.8V

LED Flashlight
Lampu Suluh LED
LED 3000LM

Vacuum Cleaner
Pembersih Vakuum
真空吸尘器

Drilling / Fastening
Gergaji / Pengikat
电钻 / 紧固件

Impact Drilling / Demolition
Gergaji / Pemecah
电钻 / 拆墙机

Cutting
Pemotong
切割机

Grinding / Sanding
Pengkilan / Pasir
打磨 / 砂磨

Sawing
Gergaji
锯切

Planing / Routing
Pengkilan / Troggam
刨削 / 开槽

Others
Lain-lain
其他

Outdoor Power Equipment
Alat-alat Kerdil Luar
户外动力设备

Makita
1915

System charts

Cordless
Tanpa Kabel Listrik

LED Flashlight
Lampu Senter LED
LED照灯

Vacuum Cleaner
Penyerap Vakum
吸尘器

Drilling / Fastening
Drooi / Pengikat
钻孔 / 紧固

Impact Drilling / Demolition
Drooi / Perusak
冲击钻孔 / 拆除加工

Cutting
Pemotong
切割

Grinding / Sanding
Pengkilan / Pasiran
打磨 / 砂磨



Sawing
Gergaji
锯切

Planing / Routing
Pengaliran / Pengaliran
刨削 / 雕刻









Others
Lain-lain
其他

Outdoor Power Equipment
Alat-alat Listrik
园林工具

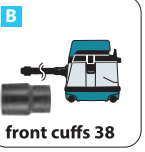
Makita
Makita

For Model	Suction Systems and Part No.
Plate Joiner PJ7000, 3901, DPJ180, DPJ140	 <p>A front cuffs 22</p>
	 <p>B front cuffs 22</p>
Cut-out Tool 3706	 <p>C* front cuffs 22</p>
Cordless Cut-out Tool DCO180	 <p>D Joint 22-38 195548-6</p>
Cordless Drywall saw DSD180, SD100D	 <p>E front cuffs 22</p>
Router RP0910, RP1110C	

*C: DVC350 Cannot be used with Router models

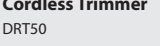
For Model	Suction Systems and Part No.
Router RP1801/ F RP1800/ F RP2301FC RP2300FC	Dust nozzle 194934-8
	 <p>A front cuffs 38</p>
Router RD1100, RD1101, RF1100, RF1101, RP1100, RP1101	Dust nozzle 193379-7
	 <p>B front cuffs 38</p>
Router RP0900, ***RT0700C, DRT50	Dust nozzle 194733-8
Cordless Router DRT50	 <p>C front cuffs 38</p>
	 <p>D front cuffs 38</p>
*** Use with Plunge base assembly	 <p>E front cuffs 38</p>
Trimmer RT0700C	Dust nozzle 195559-1
	 <p>A front cuffs 38</p>
Cordless Trimmer DRT50	

Makita recommend to use 38mm hose when you use Router

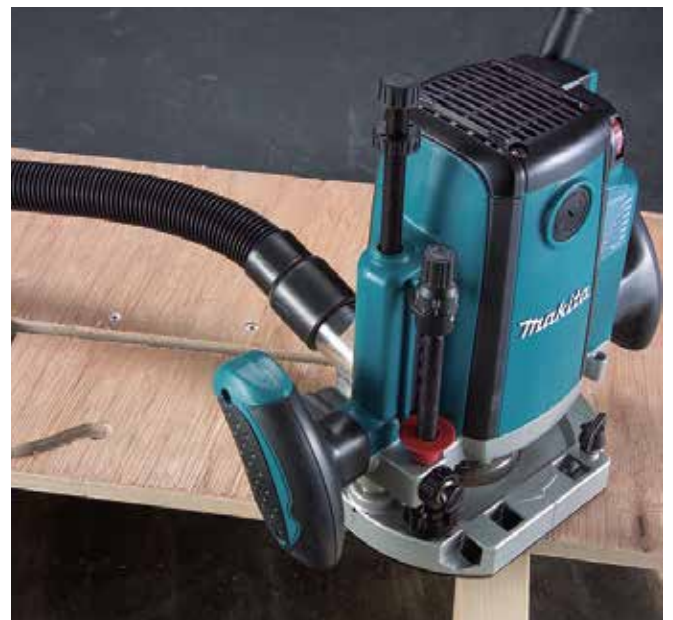

Front cuffs & Joint

Front cuffs 22



Front cuffs 24



Front cuffs 38



Joint 22-38



Joint 38



Joint H



Rubber sleeve 18-21



Type	Part No.
Front cuffs 22	195547-8
Front cuffs 24	195546-0
Front cuffs 38	195545-2
Joint 22-38	195548-6

Hose connection 28mm

28-A

Hose



Note:
Can be connected with power tools, Front cuffs and Joint are required for some power tools.

*DVC260, DVC261, DVC265 only

* for cleaning (Use with Bending pipe assembly)

Size	Length (m)	with Front cuffs	Part No.
28mm	1.0	-	*143787-2
28mm	1.5	38	*152992-0
28mm	1.5	22, 38	A-34235
28mm	2.5	22, 24, 38	195437-5
28mm	3.5	22, 24, 38	195433-3
28mm	5	22, 24, 38	195436-7
28mm	5	22, 38	A-34229

28-B

Bending pipe

*with Hose 28 sleeve



Description	Part No.
For Aluminum (Part No. 140G19-0) Telescopic pipe assembly with lock	*127093-3
For plastic straight pipe 28 and Telescopic pipe assembly 28	*126756-8

28-C

Straight pipe



Description	Part No.
Aluminum Telescopic pipe assembly Pipe length is variably adjustable from 590 to 942mm.	140G19-0
Telescopic pipe assembly 28 Pipe length is variably adjustable from 500 to 850mm.	198560-5

28-D

Nozzle assembly

Flat type



F/C switching t-nozzle 28
Flooring & carpet



Floor/carpet t-nozzle
For rug / carpet cleaning



For rug / carpet cleaning



Floor t-nozzle 28



Seat nozzle 28
For car seat



Description	Color	Part No.	EU
			Part No.
F/C switching t-nozzle 28 Flooring & carpet	White	198183-9	198532-0
Floor/carpet t-nozzle For rug / carpet cleaning	White	198525-7	-
	Black	198526-5	-
Floor t-nozzle 28	White	123486-2	-
Seat nozzle 28 For car seat	White	-	199038-1
	Black	-	199039-9

Cordless
Tampal Kord 10.8V

LED Flashlight
Lampu Saku LED
LED303030

Vacuum Cleaner
Pembersih Vakuum
真空吸尘器

Drilling / Fastening
Gergaji / Pengikat
钻头 / 紧固件

Impact Drilling / Demolition
Gergaji / Perusak
打桩机 / 破拆工具

Cutting
Pemotong
切割机

Grinding / Sanding
Pengkilan / Pasukan
打磨 / 砂磨

Sawing
Gergaji
锯切

Planing / Routing
Pengkilan / Troggaman
刨削 / 雕刻

Others
Lain-lain
其他

Outdoor Power Equipment
Alat-alat Keras Luar
户外动力工具

Makita
MAKITA

Cordless
Turret Hood 无绳式

LED Flashlight
Lampu Senter LED
LED 手电筒

Vacuum Cleaner
Pembersih Vakum
吸尘器

Drilling / Fastening
Dremel / Pengencat
钻头 / 紧固

Impact Drilling / Demolition
Dremel / Perusak
起工钻头 / 凿墙加工

Cutting
Pemotong
切割

Grinding / Sanding
Pengkilan / Polesan
打磨 / 砂磨

Sawing
Gergaji
锯切

Planing / Routing
Pengaliran / Tenggeram
刨削 / 雕刻

Others
Lain-lain
其他

Outdoor Power Equipment
Alat-alat Kerja Luar
园机 / 户外



28-E
Round brush



Color	Part No.
White	198878-4
Black	198551-6

28-F
Corner nozzle

Type	Color	Part No.
300-28mm	White	198919-6
	Black	198992-6
Crevice nozzle 415 set	White	199439-3

28-G
Shelf brush

(For gentle cleaning by soft-tipped brush)



Color	Part No.	EU
		Part No.
White	198872-6	198873-4
Black	198536-2	-

28-H
Flexible rubber nozzle



Color	Part No.	EU
		Part No.
grey	197900-4	197901-2

28-I
Tapered nozzle set

Use with Front cuts 22 or Flexible rubber nozzle



Color	Part No.
grey	192236-6

Hose stand

For model
VC1310L, VC2211M, VC2510L,
VC3210L, VC3211M



Part No.
197323-6

Holder set 10-33



Part No.
195544-4



Hose connection 38mm

38-A

Hose 38mm

for cleaning

*Use with 28-B Bending pipe assembly



Size	Length (m)	with Front cuffs	Part No.
38mm	2.5	38	195434-1
38mm	5	38	195435-9

Cleaning set

Includes one each of:

- Hose complete 38-2.5
- Straight pipe
- Bending pipe
- Nozzle assembly
- Corner nozzle



Part No.
195439-1

38-B Bending pipe



Description	Part No.
Aluminum	192562-3

38-C Straight pipe



Description	Part No.
Aluminum	192563-1

38-D Nozzle assembly

Flooring & carpet



Universal Type



Compact Type A

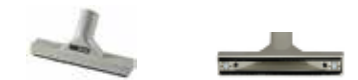

Compact Type B
(wet model only)



Wide Type
(wet model only)



Description	Dry/ Wet	Part No.	EU
			Part No.
Flooring & carpet	Dry	198184-7	-
Universal Type	Dry/ Wet	195551-7	-
Compact Type A	Dry	195549-4	122334-2
Compact Type B	Wet	195550-9	-
Wide Type	Wet	A-47846	-

38-E Round brush



Type	Color	Part No.
38mm	Black	191657-9

38-F Corner nozzle



Type	Color	Part No.
38mm	Yellow grey	410306-2

Cordless
Tegak Kord ไร้สาย

LED Flashlight
Lampu Suluh LED
LED 383833

Vacuum Cleaner
Pembersih Vakuum
吸尘器

Drilling / Fastening
Gergaji / Pengikat
电钻 / 紧固件

Impact Drilling / Demolition
Gergaji / Pemecok
电锤 / 冲击钻

Cutting
Pemotong
切割机

Grinding / Sanding
Pemoles / Pasir
打磨 / 砂磨

Sawing
Gergaji
锯切

Planing / Routing
Pencelakan / Tenggam
刨削 / 雕刻

Others
Lain-lain
其他

Outdoor Power Equipment
Alat-alat Kerdil Luar
园林工具

Makita
MAKITA

DRILLING | FASTENING

Cordless
Turret Head 手枪式

LED Flashlight
Lampu Cahaya LED
LED 照明灯

Vacuum Cleaner
Pembersih Vakum
吸尘器

Drilling / Fastening
Gerudi / Pemutar
钻孔 / 紧固

Impact Drilling / Demolition
Gerudi / Persekol
冲击钻孔 / 拆除加工

Cutting
Pemotong
切割

Grinding / Sanding
Pengamir / Poles
打磨 / 砂磨

Sawing
Gergaji
锯切

Planing / Routing
Pengaliran / Tanggapan
刨削 / 雕刻

Others
Lain-lain
其他

Outdoor Power Equipment
Alat-alat Kerja Luar
园机-户外

Makita
19157

DP2010 6.5mm (1/4")

419 W

High Speed Drill Gerudi Kelajuan Tinggi 高速钻



- Compact and high power
Kuasa tinggi dan padat
紧凑和高功率

Standard Equipment: Chuck Key



Continuous Rating Input Input Kuasa Berterusan 额定输入功率	370W
Capacity Kapasiti 能力	Steel: 6.5mm (1/4") Wood: 15mm (9/16")
No Load Speed (RPM) Kelajuan Tanpa Beban 回转速数	0-4,200
Dimensions (L x W x H) Dimensi 体积	209x64x175mm (8-1/4"x2-1/2"x6-7/8")
Net Weight Berat Bersih 净重	1.0kg (2.2lbs.)
Power Supply Cord Kabel Wayar 电源线	2.0m (6.6ft)

DF0300 10mm (3/8")

411 W

Driver Drill Gerudi Pemutar Skru 螺丝起子电钻



- Compact Design with a Short Overall Length
Reka bentuk padat dan pendek
紧凑小巧的设计

Standard Equipment: (+/-) Bit



Continuous Rating Input Input Kuasa Berterusan 额定输入功率	320W
Capacity Kapasiti 能力	Steel: 10mm (3/8") Wood: 28mm (1-1/8")
Chuck Capacity Kapasiti Chuck 夹头能力	1.0 - 10mm (1/32 - 3/8")
No Load Speed (RPM) Kelajuan Tanpa Beban 回转速数	High: 0 - 1,500 Low: 0 - 450
Max Fastening Torque Tenaga Pemutaran Pengancing Maksimum 最快扭转	Hard 56.0N·m (500in.lbs.) Soft: 21.0N·m (190in.lbs.)
Max Lock Torque Pemutaran Tenaga Maksimum 最大锁定扭力	42.0N·m (370in.lbs.)
Dimensions (L x W x H) Dimensi 体积	220x67x206mm (8-5/8"x2-5/8"x8-1/8")
Net Weight Berat Bersih 净重	1.2kg (2.7lbs.)
Power Supply Cord Kabel Wayar 电源线	2.5m (8.2ft)

6412 10mm (3/8")

64 W

Drill Gerudi 电钻



- Compact and lightweight, yet with enough power
Padat dan ringan, namun dengan kuasa yang mencukupi
小巧轻便，但功率充足

Standard Equipment: Chuck Key



Continuous Rating Input Input Kuasa Berterusan 额定输入功率	450W
Capacity Kapasiti 能力	Steel: 10mm (3/8") Wood: 25mm (1")
No Load Speed (RPM) Kelajuan Tanpa Beban 回转速数	0-3,400
Dimensions (L x W x H) Dimensi 体积	228x64x183mm (9x2-1/2"x7-1/4")
Net Weight Berat Bersih 净重	1.3kg (2.9lbs)
Power Supply Cord Kabel Wayar 电源线	2.0m (6.6ft)

6413 10mm (3/8")

64 W

Drill Gerudi 电钻



- General Purpose Drill Featuring Compact And Lightweight Design
Reka Bentuk Kompak Dan Ringan untuk penggerudian tujuan umum
紧凑轻巧机身适合一般用途



Continuous Rating Input Input Kuasa Berterusan 额定输入功率	450W
Capacity Kapasiti 能力	Steel: 10mm (3/8") Wood: 25mm (1")
No Load Speed (RPM) Kelajuan Tanpa Beban 回转速数	0-3,400
Dimensions (L x W x H) Dimensi 体积	234x64x183mm (9-1/4"x2-1/2"x7-1/4")
Net Weight Berat Bersih 净重	1.3kg (2.9lbs)
Power Supply Cord Kabel Wayar 电源线	2.0m (6.6ft)

6305 13mm (1/2")

303 W

Drill Gerudi 电钻



- Heavy duty motor
Motor tugas berat unggul
卓越马达

Standard Equipment: Chuck Key, Depth Gauge, Side Grip



Continuous Rating Input Input Kuasa Berterusan 额定输入功率	850W
Capacity Kapasiti 能力	Steel: 13mm (1/2") Wood: 30mm (1-3/16")
No Load Speed (RPM) Kelajuan Tanpa Beban 回转速数	1,450
Dimensions (L x W x H) Dimensi 体积	346x84x152mm (13-5/8"x3-5/16"x6")
Net Weight Berat Bersih 净重	2.8kg (6.2lbs.)
Power Supply Cord Kabel Wayar 电源线	2.5m (8.2ft)

DRILLING | FASTENING

DS5000 16mm (5/8")

411

Drill
Gerudi
电钻



- **Powerful 750W motor for improved mixing and drilling performance**
Motor berkuasa 750W untuk prestasi pencampuran dan penggerudian yang lebih baik
强劲的750W马达提高混合和钻孔性能

Standard Equipment: Chuck Key, Top Grip



Continuous Rating Input Input Kuasa Berterusan 额定输入功率	750W
Capacity Kapasiti 能力	Steel: 16mm (5/8") Wood: 36mm (1-7/16")
No Load Speed (RPM) Kelajuan Tanpa Beban 回转数	600
Dimensions (L x W x H) Dimensi 体积	348x83x401mm (13-3/4"x3-1/4"x15-3/4")
Net Weight Berat Bersih 净重	3.0kg (6.6lbs)
Power Supply Cord Kabel Wayar 电源线	2.5m (8.2ft)

DS4012 13mm (1/2")

411

Drill
Gerudi
电钻



- **All-ball bearing construction for durability and longer tool life**
Struktur gilas bola untuk memanjangkan hayat alat
滚珠轴承结构延长工具寿命

Standard Equipment: Chuck Key, Top Grip



Continuous Rating Input Input Kuasa Berterusan 额定输入功率	750W
Capacity Kapasiti 能力	Steel: 13mm (1/2") Wood: 36mm (1-7/16")
No Load Speed (RPM) Kelajuan Tanpa Beban 回转数	0-600
Dimensions (L x W x H) Dimensi 体积	340x83x390mm (13-3/8"x3-1/4"x15-3/8")
Net Weight Berat Bersih 净重	2.8kg (6.2lbs)
Power Supply Cord Kabel Wayar 电源线	2.5m (8.2ft)

6016 16mm (5/8")

51

Drill
Gerudi
电钻



- **D-handle rotates 360 degrees for multi-position operation**
Pemegang-D berputar 360° memudahkan operasi
360° 旋转D型手柄方便操作

Standard Equipment: Chuck Key, Depth Gauge, Top Grip



Continuous rating input Input Kuasa Berterusan 额定输入功率	480W
Capacity Kapasiti 能力	Steel: 16mm (5/8") Wood: 36mm (1-3/8")
No Load Speed (RPM) Kelajuan Tanpa Beban 回转数	700
Overall Length Panjang Keseluruhan 总长度	365mm (14-3/8")
Net weight Berat Bersih 净重	4.4kg (9.7lbs)
Power supply cord Kabel Wayar 电源线	2.5m (8.2ft)

DA3010F 10mm (3/8")

419

Angle Drill
Gerudi Sudut
角向电钻



- **Powerful 450W motor with less weight**
Motor berkuasa 450W dan ringan
轻量且强劲的450W马达

Standard Equipment: Chuck Key, Side grip 36 complete



Continuous Rating Input Input Kuasa Berterusan 额定输入功率	450W
Capacity Kapasiti 能力	Steel: 10mm (3/8") Wood: 25mm (1")
No Load Speed (RPM) Kelajuan Tanpa Beban 回转数	0-2,400
Overall Length Panjang Keseluruhan 总长度	270mm (10-5/8")
Net Weight Berat Bersih 净重	1.6kg (3.5lbs)
Power Supply Cord Kabel Wayar 电源线	2.5m (8.2ft)

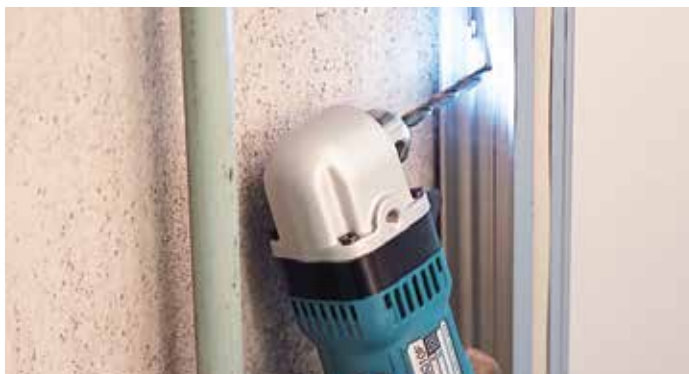

Cordless
Tangkas Kord 无线式

LED Flashlight
Lampu Suhu LED
LED照明灯

Vacuum Cleaner
Pembersih Vakuum
吸尘器

Drilling / Fastening
Gerudi / Pasang
钻孔 / 紧固

Impact Drilling / Demolition
Gerudi / Pasang
石工钻孔 / 砸墙施工

Cutting
Pemotong
切割

Grinding / Sanding
Pengam / Pasah
研磨 / 砂磨

Sawing
Gergaji
锯切

Planing / Routing
Pengerus / Tangan
刨削 / 雕刻

Others
Lain-lain
其他

Outdoor Power Equipment
Alatan Kuasa Luar
户外动力设备

Makita
MAKITA

DRILLING | FASTENING

Cordless
Tanpa Kabel / 无线式

LED Flashlight
Lampu Bawah LED
LED 照明灯

Vacuum Cleaner
Pembersih Vakum
吸尘器

Drilling / Fastening
Otomatis / Pengotot
钻孔 / 紧固

Impact Drilling / Demolition
Ganjal / Pemecah
起工钻孔 / 砸裂加工

Cutting
Pemotong
切割

Grinding / Sanding
Pengamir / Poles
打磨 / 研磨

Sawing
Gergaji
锯切

Planing / Routing
Pengaliran / Tanggapan
刨削 / 雕刻

Others
Lain-lain
其他

Outdoor Power Equipment
Alatan Kerja Luar
园具 / 户外

Makita
19157



TD0100

419

Impact Driver Pemutar Skru Impak 冲击螺丝起子机



- **Impacting mechanism for secure fastening**
Mekanisme Impak untuk pengetatan yang kukuh
冲击机构确保紧固

Standard Equipment: Phillips Bit



Continuous rating input Input Kuasa Berterusan 额定输入功率	230W
Capacity Kapasiti 能力	Machine Screw: M4 - M8 (5/32" - 5/16") Standard Bolt: M5 - M14 (3/16" - 9/16") High Tensile Bolt: M5 - M10 (3/16" - 3/8") Coarse thread (in length): 22 - 90mm (7/8" - 3-1/2")
Driving Shank (Hex) Hex Memandu Aci 六角驱动轴	6.35mm (1/4")
Impacts Per Minute (IPM) Impak Per Minit 冲击数	0 - 3,200
No Load Speed (RPM) Kelajuan Tanpa Beban 回转速数	0 - 3,600
Max Fastening Torque Maksimum Tenaga Pemutaran Pengancing 最快扭力	100N-m (74ft.lbs.)
Dimensions (L x W x H) Dimensi 体积	218x60x180mm (8-5/8"x2-3/8"x7-1/8")
Net weight Berat Bersih 净重	0.96kg (2.1lbs)
Power supply cord Kabel Wayar 电源线	2.5m (8.2ft)

TD0101F

411

Impact Driver Pemutar Skru Impak 冲击螺丝起子机



- **Enables to drive screws even without pre-drilling pilot holes**
Skru boleh digerudi walaupun tanpa lubang pra-penggerudian
即使没有预钻孔也可以驱动螺钉

Standard Equipment: Phillips Bit



Continuous rating input Input Kuasa Berterusan 额定输入功率	230W
Capacity Kapasiti 能力	Machine Screw: M4 - M8 (5/32" - 5/16") Standard Bolt: M5 - M14 (3/16" - 9/16") High Tensile Bolt: M5 - M10 (3/16" - 3/8") Coarse thread (in length): 22 - 90mm (7/8" - 3-1/2")
Driving Shank (Hex) Hex Memandu Aci 六角驱动轴	6.35mm (1/4")
Impacts Per Minute (IPM) Impak Per Minit 冲击数	0 - 3,200
No Load Speed (RPM) Kelajuan Tanpa Beban 回转速数	0 - 3,600
Max Fastening Torque Maksimum Tenaga Pemutaran Pengancing 最快扭力	100N-m (74ft.lbs.)
Dimensions (L x W x H) Dimensi 体积	184x67x192mm (7-1/4"x2-5/8"x7-9/16")
Net weight Berat Bersih 净重	0.99kg (2.2lbs)
Power supply cord Kabel Wayar 电源线	2.5m (8.2ft)

FS2300

419

Drywall Screwdriver Pemutar Skru Drywall 石膏板螺丝起子机



- **Large trigger with lock-on button for operator convenience**
Butang pencetus dengan fungsi mengunci untuk memudahkan pengguna
备有锁定功能的触发按钮方便操作

Standard Equipment: Phillips Insert Bit x2, Magnetic Bit Holder



Continuous Rating Input Input Kuasa Berterusan 额定输入功率	570W
Capacity Kapasiti 能力	Drywall Screw: 5mm (3/16") Self-Drilling Screw: 6mm (1/4")
Driving Shank (Hex) Hex Memandu Aci 六角驱动轴	6.35mm (1/4")
No Load Speed (RPM) Kelajuan Tanpa Beban 回转速数	0 - 2,500
Dimensions (L x W x H) Dimensi 体积	290x70x207mm (11-3/8"x2-3/4"x8-1/8")
Net Weight Berat Bersih 净重	1.6kg (3.5lbs)
Power Supply Cord Kabel Wayar 电源线	2.5m (8.2ft.)

DRILLING | FASTENING

FS2500

419 WATT

Screwdriver

Pemutar Skru
螺丝起子机



- **Aluminum gear housing for less weight and increased durability**
Lebih tahan lama dan ringan dengan gear aluminium
铝合金齿轮更轻更耐用

Standard Equipment: **Magnetic Socket Bit**



Continuous Rating Input Input Kuasa Berterusan 额定输入功率	570W
Capacity Kapasiti 能力	Drywall Screw: 5mm (3/16") Self-Drilling Screw: 6mm (1/4") 6.35mm (1/4")
Driving Shank (Hex) Hex Memandu Aci 六角驱动轴	6.35mm (1/4")
No Load Speed (RPM) Kelajuan Tanpa Beban 回转数	0 - 2,500
Dimensions (L x W x H) Dimensi 体积	280x70x207mm (11"x2-3/4"x8-1/8")
Net Weight Berat Bersih 净重	1.5kg (3.4lbs)
Power Supply Cord Kabel Wayar 电源线	2.5m (8.2ft.)

FS2700

419 WATT

Screwdriver

Pemutar Skru
螺丝起子机



- **6 stage adjustable torque adjustment for a wide range of applications**
6 tahap pelarasan tork untuk pelbagai aplikasi
6级扭力调节适合各种应用



Continuous Rating Input Input Kuasa Berterusan 额定输入功率	570W
Capacity Kapasiti 能力	Self-Drilling Screw: 6mm (1/4") Machine Screw: 8mm (5/16") Wood Screw: 6.2mm (1/4")
Driving Shank (Hex) Hex Memandu Aci 六角驱动轴	6.35mm (1/4")
No Load Speed (RPM) Kelajuan Tanpa Beban 回转数	0 - 2,500
Dimensions (L x W x H) Dimensi 体积	301x70x207mm (11-7/8"x2-3/4"x8-1/8")
Net Weight Berat Bersih 净重	1.8kg (4lbs)
Power Supply Cord Kabel Wayar 电源线	2.5m (8.2ft.)

FS4200

419 WATT

Drywall Screwdriver

Pemutar Skru Papan Gypsum
石膏板螺丝起子机



- **Powerful 570W motor**
Motor berkuasa 570W
570W强力马达

Standard Equipment: **Phillips Insert Bit x2, Magnetic Bit Holder**



Continuous Rating Input Input Kuasa Berterusan 额定输入功率	570W
Capacity Kapasiti 能力	Drywall Screw: 5mm (3/16") Self-Drilling Screw: 6mm (1/4") 6.35mm (1/4")
Driving Shank (Hex) Hex Memandu Aci 六角驱动轴	6.35mm (1/4")
No Load Speed (RPM) Kelajuan Tanpa Beban 回转数	0 - 4,000
Dimensions (L x W x H) Dimensi 体积	269x65x207mm (10-5/8"x2-9/16"x8-1/8")
Net Weight Berat Bersih 净重	1.4kg (3lbs)
Power Supply Cord Kabel Wayar 电源线	2.5m (8.2ft.)

FS6300

419 WATT

Drywall Screwdriver

Pemutar Skru Papan Gypsum
石膏板螺丝起子机



- **Silent clutch for improved performance and durability**
Klac senyap untuk prestasi dan ketahanan yang lebih baik
静音离合器提高性能和耐用性

Standard Equipment: **Phillips Insert Bit x2, Magnetic Bit Holder**



Continuous Rating Input Input Kuasa Berterusan 额定输入功率	570W
Capacity Kapasiti 能力	Drywall Screw: 4mm (5/32")
Driving Shank (Hex) Hex Memandu Aci 六角驱动轴	6.35mm (1/4")
No Load Speed (RPM) Kelajuan Tanpa Beban 回转数	0 - 6,000
Dimensions (L x W x H) Dimensi 体积	279x65x207mm (11"x2-9/16"x8-1/8")
Net Weight Berat Bersih 净重	1.4kg (3.1lbs)
Power Supply Cord Kabel Wayar 电源线	2.5m (8.2ft.)

UT1305

303 WATT

Mixer

Pengadun
搅拌机



- **Heavy duty and high speed mixer**
Tahan lasak dan kelajuan tinggi
耐用和高速

Standard Equipment: **Wrenches, Side Grip, Blade**



Continuous Rating Input Input Kuasa Berterusan 额定输入功率	850W
Blade Diameter Diameter Bilah 锯片直径	165mm (6-1/2")
No Load Speed (RPM) Kelajuan Tanpa Beban 回转数	1,300
Shank Size of Tool Holder Portion Batang Saiz 柄部尺寸	M12
Dimensions (L x W x H) Dimensi 体积	942x87x152mm (37"x3-7/16"x6")
Net Weight Berat Bersih 净重	2.6kg (5.7lbs)
Power Supply Cord Kabel Wayar 电源线	2.5m (8.2ft.)

Cordless
Tangkas Kord 无绳式

LED Flashlight
Lampu Suhu LED
LED照明灯

Vacuum Cleaner
Pembersih Vakuum
吸尘器

Drilling / Fastening
Ganda / Pengikat
钻孔 / 紧固

Impact Drilling / Demolition
Ganda / Peneh
石工钻孔 / 拆毁施工

Cutting
Pemotong
切割

Grinding / Sanding
Pengisar / Pech
研磨 / 砂磨

Sawing
Ganda
锯切

Planing / Routing
Pengaliran / Tunggam
刨削 / 雕刻

Others
Lain-lain
其他

Outdoor Power Equipment
Alatan Kuasa Luar
户外动力设备

Makita
MAKITA

DRILLING | FASTENING

UT2204

303

Mixer Pengadun 搅拌机



- **Heavy duty and high speed mixer**
Tahan lasak dan kelajuan tinggi
耐用和高速

Standard Equipment: **Wrenches, Side Grip**



Continuous rating input Input Kuasa Berterusan 额定输入功率	850W
Blade Diameter Diameter Bilah 锯片直径	220mm (8-5/8")
No Load Speed (RPM) Kelajuan Tanpa Beban 回转数	550
Shank Size of Tool Holder Portion Batang Saiz 柄部尺寸	M12 or M14
Dimensions (L x W x H) Dimensi 体积	929x89x152mm (36-1/2"x3-1/2"x6")
Net weight Berat Bersih 净重	2.7kg (5.9lbs)
Power supply cord Kabel Wayar 电源线	2.5m (8.2ft)

TW1000 25.4mm (1")

153

Impact Wrench Perengkuh Impak 套筒扳手



- **Huge 1,000N-m (738 ft.lbs.) of Power for Industrial Applications**
Kuasa 1,000N-m (738 ft.lbs.) untuk aplikasi perindustrian
巨大的 1,000N - m (738 ft.lbs.) 功率适合工业应用

Standard Equipment: **Side Grip, Socket**



Continuous Rating Input Input Kuasa Berterusan 额定输入功率	1,200W
Fastening Capacities Kapasiti 能力	Standard Bolt: M24 - M30 (15/16" - 1-3/16") High Tensile Bolt: M22 - M24 (7/8" - 15/16")
Square Drive Batang Segi Empat 四方头	25.4mm (1")
No Load Speed (RPM) Kelajuan Tanpa Beban 回转数	1,400
Impacts Per Minute (IPM) Impak Per Minit 冲击数	1,500
Max Fastening Torque Maksimum Tenaga Pemutaran Pengancing 最快扭力	1,000N-m (738ft.lbs.)
Dimensions (L x W x H) Dimensi 体积	382x110x290mm (15"x4-5/16"x11-3/8")
Net Weight Berat Bersih 净重	8.8kg (19.4lbs)
Power Supply Cord Kabel Wayar 电源线	2.5m (8.2ft)

6906 19mm (3/4")

100

Impact Wrench Perengkuh Impak 套筒扳手



- **Powerful 850W motor**
Motor berkuasa 850W
强大的850W马达

Standard Equipment: **Side Grip, Socket**



Continuous Rating Input Input Kuasa Berterusan 额定输入功率	850W
Capacity Kapasiti 能力	Standard Bolt: M16 - M22 (5/8" - 7/8") High Tensile Bolt: M16 - M20 (5/8" - 3/4")
Square Drive Batang Segi Empat 四方头	19mm (3/4")
No Load Speed (RPM) Kelajuan Tanpa Beban 回转数	1,700
Impacts Per Minute (IPM) Impak Per Minit 冲击数	1,600
Max Fastening Torque Maksimum Tenaga Pemutaran Pengancing 最快扭力	588 N-m (441ft.lbs.)
Overall Length Dimensi 体积	327mm (12-7/8")
Net Weight Berat Bersih 净重	5.6kg (12.2lbs)
Power Supply Cord Kabel Wayar 电源线	2.5m (8.2ft)

6905B 12.7mm (1/2")

65

Impact Wrench Perengkuh Impak 套筒扳手



- **Aluminum hammer case with high durability**
Casing aluminium yang bertahan
铝制外壳更耐用

Standard Equipment: **Socket 19, 22, 24**



Continuous Rating Input Input Kuasa Berterusan 额定输入功率	440W
Fastening Capacities Kapasiti 能力	Standard Bolt: M12 - M20 (1/2" - 3/4") High Tensile Bolt: M12 - M16 (1/2" - 5/8")
Square Drive Batang Segi Empat 四方头	12.7mm (1/2")
No Load Speed (RPM) Kelajuan Tanpa Beban 回转数	1,700
Impacts Per Minute (IPM) Impak Per Minit 冲击数	2,000
Max Fastening Torque Maksimum Tenaga Pemutaran Pengancing 最快扭力	294N-m (217ft.lbs.)
Overall Length Dimensi 体积	270mm (10-5/8")
Net Weight Berat Bersih 净重	2.8kg (6.2lbs)
Power Supply Cord Kabel Wayar 电源线	2.5m (8.2ft)

TW0350 12.7mm (1/2")

411

Impact Wrench Perengkuh Impak 套筒扳手



- **Large, efficient hammer creates more impacts for greater power**
Penukul kecekapan tinggi untuk hentaman yang lebih kuat
高效率锤子给予更强的撞击力

Standard Equipment: **Socket**



Continuous Rating Input Input Kuasa Berterusan 额定输入功率	400W
Fastening Capacities Kapasiti 能力	Standard Bolt: M12 - M22 (1/2" - 7/8") High Tensile Bolt: M12 - M16 (1/2" - 5/8")
Square Drive Batang Segi Empat 四方头	12.7mm (1/2")
No Load Speed (RPM) Kelajuan Tanpa Beban 回转数	2,000
Impacts Per Minute (IPM) Impak Per Minit 冲击数	2,000
Max Fastening Torque Maksimum Tenaga Pemutaran Pengancing 最快扭力	350N-m (260ft.lbs.)
Dimensions (L x W x H) Dimensi 体积	283x87x233mm (11-1/8"x3-7/16"x9-1/8")
Net Weight Berat Bersih 净重	3kg (6.6lbs)
Power Supply Cord Kabel Wayar 电源线	2.5m (8.2ft)

DRILLING | FASTENING

TWO200 12.7mm (1/2")

411

Impact Wrench

Perengkuh Impak
套筒扳手



- Compact and lightweight design for use in tight spaces
Sesuai untuk digunakan di ruang kecil
方便用于小空间

Standard Equipment: Socket, Hook



Continuous Rating Input Input Kuasa Berterusan 额定输入功率	380W
Fastening Capacities Kapasiti 能力	Standard Bolt: M10 - M16 (3/8" - 5/8") High Tensile Bolt: M10 - M12 (3/8" - 1/2") 12.7mm (1/2")
Square Drive Balang Segi Empat 四方头	
No Load Speed (RPM) Kelajuan Tanpa Beban 回转数	0 - 2,200
Impacts Per Minute (IPM) Impak Per Minit 冲击数	0 - 2,200
Max Fastening Torque Maksimum Tenaga Pemutaran Pengancing 最快扭力	200N-m (150ft.lbs.)
Dimensions (L x W x H) Dimensi 体积	251x72x220mm (9-7/8"x2-13/16"x8-5/8")
Net Weight Berat Bersih 淨重	2.1kg (4.7lbs)
Power Supply Cord Kabel Wayar 电源线	2.5m (8.2ft)

6922NB M16 (5/8"), M20 (3/4"), M22 (7/8")

411

Shear Wrench

Perengkuh Ricih
扭断式套筒扳手



- Compact and Lightweight Yet Powerful
Kompak dan ringan namun berkuasa
小巧轻便功能强大

Standard Equipment: Screwdriver, Sleeve M20, Sleeve M22



Continuous Rating Input Input Kuasa Berterusan 额定输入功率	1,330W
Capacity Kapasiti 能力	Bolt : M16, M20, M22 (5/8", 3/4", 7/8")
No Load Speed (RPM) Kelajuan Tanpa Beban 回转数	18
Max Fastening Torque Maksimum Tenaga Pemutaran Pengancing 最快扭力	804N-m (593ft.lbs.)
Dimensions (L x W x H) Dimensi 体积	249x84x252mm (9-13/16"x3-5/16"x9-15/16")
Net Weight Berat Bersih 淨重	4.9kg (10.8lbs)
Power Supply Cord Kabel Wayar 电源线	2.5m (8.2ft)

6924N M22 (7/8"), M24 (1"), SHTB22

303

Shear Wrench

Perengkuh Ricih
扭断式套筒扳手



- High rotational speed for more efficient operation
Kelajuan putaran tinggi untuk operasi yang lebih cekap
高转速提高操作效率

Standard Equipment: Screwdriver, Sleeve M24



Continuous Rating Input Input Kuasa Berterusan 额定输入功率	1,050W
Capacity Kapasiti 能力	Bolt : M22, M24, 7/8", 1" Super high tensile bolt : M22 19
No Load Speed (RPM) Kelajuan Tanpa Beban 回转数	
Max Fastening Torque Maksimum Tenaga Pemutaran Pengancing 最快扭力	1,100N-m (810ft.lbs.)
Dimensions (L x W x H) Dimensi 体积	330x104x257mm (13"x4-1/8"x10-1/8")
Net Weight Berat Bersih 淨重	7.5kg (16.6lbs)
Power Supply Cord Kabel Wayar 电源线	2.5m (8.2ft)

HB500 50mm (2")

Magnetic Drill

Gerudi Magnet
磁力钻孔机



- Magnetic base, drill stand, and drill machine all in one package system
Dasar bermagnet, mesin dan penegak gerudi dalam satu sistem
磁性底座, 钻架和钻机集在同一系统

Standard Equipment: Quick release arbor, Small oil cup assembly and clip, Safety guard, Polyester safety strap, Integral oil feed steady allen keys



Continuous Rating Input Input Kuasa Berterusan 额定输入功率	1,150W
Capacity Kapasiti 能力	Steel: 50mm (2")
Chuck Capacity Kapasiti Chuck 夹头能力	16mm (5/8")
No Load Speed (RPM) Kelajuan Tanpa Beban 回转数	350 / 650
Magnetic Clamping Force Kekuatan Penjepit Magnetik 磁力夹紧力	Minimum 9,300N (950kg)
Dimensions (L x W x H) Dimensi 体积	290x150x450mm (11-3/8"x5-7/8"x17-3/4")
Net Weight Berat Bersih 淨重	18.5kg (40.8lbs)

HB350 35mm (1-3/8")

UD00EBD002

Magnetic Drill

Gerudi Magnet
磁力钻孔机



- Magnetic base, drill stand, and drill machine all in one package system enables for easy setting
Dasar bermagnet, mesin dan penegak gerudi dalam satu sistem
磁性底座, 钻架和钻机集在同一系统

Standard Equipment: Small Oil Cup Assembly and Clip, Safety guard, Polyester safety strap, Allen keys



Continuous Rating Input Input Kuasa Berterusan 额定输入功率	1,050W
Capacity Kapasiti 能力	Steel: 35mm (1-3/8")
No Load Speed (RPM) Kelajuan Tanpa Beban 回转数	850
Magnetic Clamping Force Kekuatan Penjepit Magnetik 磁力夹紧力	8,000N
Dimensions (L x W x H) Dimensi 体积	270x110x330mm
Net Weight Berat Bersih 淨重	11.5kg

Cordless
Tanggap Kord 无绳LED Flashlight
Lampu Suli LED
LED 闪光灯Vacuum Cleaner
Penembih Vakuum
吸尘器Drilling / Fastening
Gerudi / Pengancing
钻孔 / 紧固Impact Drilling / Demolition
Gerudi / Penembih
冲击钻孔 / 拆毁Cutting
Pemotong
切割Grinding / Sanding
Pengamiran / Pencil
研磨 / 砂磨Sawing
Gergaji
锯切Planing / Routing
Pengaliran / Tunggam
刨削 / 雕花Others
Lain-lain
其他Outdoor Power Equipment
Alatan Kuasa Luar
户外动力Makita
MAKITA

IMPACT DRILLING | DEMOLITION



HP0300 10mm (3/8")

411 WMI

Hammer Driver Drill

Tukul Pemutar Skru Bergerudi
冲击螺丝起子电钻



- 2-mode operation for "Rotation Only" or "Hammering with Rotation"
operasi 2 mod, penukulan dengan putaran atau hanya putaran
2档模式变换, 旋转并锤击或仅旋转

Standard Equipment: (+)(-) Bit



Continuous Rating Input Input Kuasa Berterusan 额定输入功率	320W
Capacity Kapasiti 能力	Concrete: 8mm (5/16") Steel: 10mm (3/8") Wood: 28mm (1-1/8")
Chuck Capacity Kapasiti Chuck 夹头能力	1.0 - 10mm (1/32 - 3/8")
Impacts Per Minute (IPM) Impak Per Minit 冲击数	High: 0 - 22,500 Low: 0 - 6,750
No Load Speed (RPM) Kelajuan Tanpa Beban 回转速	High: 0 - 1,500 Low: 0 - 450
Max Fastening Torque Tenaga Pemutaran Pengancing Maksimum 最快扭转	Hard 56.0N-m (500in.lbs.) Soft 21.0N-m (190in.lbs.)
Max Lock Torque Pemutaran Tenaga Maksimum 最大锁定扭力	42.0N-m (370in.lbs.)
Dimensions (L x W x H) Dimensi 体积	235x67x206mm (9-1/4"x2-5/8"x8-1/8")
Net Weight Berat Bersih 净重	1.3kg (2.8lbs.)
Power Supply Cord Kabel Wayar 电源线	2.5m (8.2ft)

HP1230 12mm (15/32")

419 WMI

Hammer Drill

Gerudi Tukul
冲击电钻



- 2 operation modes - hammering with rotation and rotation only
Operasi 2-Mod untuk Putaran Hanya atau Hammering with Rotation
仅旋转或旋转锤击的双模式操作

Standard Equipment: Chuck Key, Depth Gauge, Side Grip



Continuous Rating Input Input Kuasa Berterusan 额定输入功率	400W
Capacity Kapasiti 能力	Concrete: 12mm (15/32")/ Steel: 10mm (3/8")/ Wood: 15mm (9/16")
Chuck Capacity Kapasiti Chuck 夹头能力	1.5 - 10mm (1/16 - 3/8")
Impacts Per Minute (IPM) Impak Per Minit 冲击数	0 - 31,900
No Load Speed (RPM) Kelajuan Tanpa Beban 回转速	0 - 2,900
Dimensions (L x W x H) Dimensi 体积	239x67x188mm (9-3/8"x2-5/8"x7-3/8")
Net Weight Berat Bersih 净重	1.7kg (3.7lbs.)
Power Supply Cord Kabel Wayar 电源线	2.0m (6.6ft)

HP1630 16mm (5/8")

85 WMI

Hammer Drill

Gerudi Tukul
冲击电钻



- Lightweight with large drilling capacity up to 16mm in concrete
Ringan dengan kapasiti penggerudian yang besar sehingga 16mm dalam konkrit
轻量, 高能力, 混凝土钻孔达16mm

Standard Equipment: Side Handle, Chuck Key



Continuous Rating Input Input Kuasa Berterusan 额定输入功率	710W
Capacity Kapasiti 能力	Concrete: 16mm (5/8")/ Steel: 13mm (1/2")/ Wood: 30mm (1-1/32")
No Load Speed (RPM) Kelajuan Tanpa Beban 回转速	0 - 3,200
Impacts Per Minute (IPM) Impak Per Minit 冲击数	0 - 48,000
Dimensions (L x W x H) Dimensi 体积	296x75x204mm (11-5/8"x2-15/16"x8")
Net Weight Berat Bersih 净重	2.1kg (4.6lbs)
Power Supply Cord Kabel Wayar 电源线	2.0m (6.6ft)

HP2050 20mm (3/4")

419 WMI

2-Speed Hammer Drill

Gerudi Tukul
冲击电钻



- 2-Mode operation for Rotation Only or Hammering with Rotation
Operasi 2-Mod untuk Putaran Hanya atau Hammering with Rotation
仅旋转或旋转锤击的双模式操作

Standard Equipment: Chuck Key, Side Grip, Depth Rod



Continuous Rating Input Input Kuasa Berterusan 额定输入功率	720W
Capacity Kapasiti 能力	Concrete: 20mm (3/4")
	Steel Hi : 8mm (5/16") Steel Lo : 13mm (1/2") Wood Hi : 25mm (1") Wood Lo : 40mm (1-9/16")
Impacts Per Minute (IPM) Kelajuan Tanpa Beban 回转速	High: 0-58,000 Low: 0-24,000
No Load Speed (RPM) Impak Per Minit 冲击数	High: 0-2,900 Low: 0-1,200
Overall Length Panjang Keseluruhan 总长度	362mm (14-1/4")
Net Weight Berat Bersih 净重	2.5kg (5.6lbs)
Power Supply Cord Kabel Wayar 电源线	2.5m (8.2ft)

Cordless
Tanpa Kabel 无线式LED Flashlight
Lampu Suhu LED
LED照明灯Vacuum Cleaner
Pembersih Vakuum
吸尘器Drilling | Fastening
Operasi | Pengingat
钻孔 | 提示Impact Drilling | Demolition
Operasi | Pembersih
冲击钻孔 | 拆除加工Cutting
Pemotongan
切割Grinding | Sanding
Pengamiran | Pemoles
打磨 | 研磨Sawing
Gergaji
锯切Planing | Routing
Pengaliran | Tergamam
刨削 | 雕刻Others
Lain-lain
其他Outdoor Power Equipment
Alat-alat Kuasa Luar
园林工具Makita
Makita

IMPACT DRILLING | DEMOLITION

HR1830 18mm (11/16")

419 WATT

Rotary Hammer Tukul Putar 电锤



- 2-Mode operation for Rotation Only or Hammering with Rotation
Operasi 2-Mod untuk Putaran Hanya atau Hammering with Rotation
仅旋转或旋转锤击的双模式操作

Standard Equipment: Side Grip, Depth Gauge



Continuous Rating Input Input Kuasa Berterusan 额定输入功率	440W
Impact Energy Kekuatan Impak 单次最大锤击力	EPTA-Procedure 05/2009: 1.2J Our experimental conditions: 1.2J
Capacity Kapasiti 能力	Concrete: 18mm (11/16")/ Concrete (Diamond core bit) : 65mm (2-9/16")/ Steel: 13mm (1/2")/ Wood: 24mm (15/16")
Impacts Per Minute (IPM) Impak Per Minit 冲击数	0-5,000
No Load Speed (RPM) Kelajuan Tanpa Beban 回转数	0-1,500
Dimensions (L x W x H) Dimensi 体积	279x66x208mm (10-7/8"x2-5/8"x8-3/16")
Net Weight Berat Bersih 净重	1.9kg (4.2lbs)
Power Supply Cord Kabel Wayar 电源线	2.5m (8.2ft)

HR1840 18mm (11/16")

459 WATT

Rotary Hammer Tukul Putar 电锤



- 2-Mode operation for Rotation Only or Hammering with Rotation
Operasi 2-Mod untuk Putaran Hanya atau Hammering with Rotation
仅旋转或旋转锤击的双模式操作

Standard Equipment: Side Grip, Depth Gauge



Continuous Rating Input Input Kuasa Berterusan 额定输入功率	470W
Impact Energy Kekuatan Impak 单次最大锤击力	EPTA-Procedure 05/2009: 1.4J Our experimental conditions: 1.4J
Capacity Kapasiti 能力	Concrete: 18mm (11/16")/ Core Bit: 35mm (1-3/8")/ Diamond Core Bit (Dry Type): 65mm (2-9/16")/ Steel: 13mm (1/2")/ Wood: 24mm (15/16")
Impacts Per Minute (IPM) Impak Per Minit 冲击数	0 - 4,800
No Load Speed (RPM) Kelajuan Tanpa Beban 回转数	0 - 2,100
Dimensions (L x W x H) Dimensi 体积	285x75x208mm (11-1/4"x3"x8-3/16")
Net Weight Berat Bersih 净重	2.0 - 2.4kg (4.3 - 5.3lbs)
Power Supply Cord Kabel Wayar 电源线	2.5m (8.2ft.)

HR1841F 18mm (11/16")

459 WATT

Rotary Hammer Tukul Putar 电锤



- 2 operation modes - "Hammering with Rotation" and "Rotation" only
2 mod operasi - "Mengetuk dengan Putaran" dan "Putaran" sahaja
2种操作模式 - "旋转锤击" 和 "旋转"

Standard Equipment: Side Grip, Depth Gauge



Continuous Rating Input Input Kuasa Berterusan 额定输入功率	470W
Impact Energy Kekuatan Impak 单次最大锤击力	EPTA-Procedure 05/2009: 1.4J Our experimental conditions: 1.4J
Capacity Kapasiti 能力	Concrete: 18mm (11/16")/ Core Bit: 35mm (1-3/8")/ Diamond Core Bit (Dry Type): 65mm (2-9/16")/ Steel: 13mm (1/2")/ Wood: 24mm (15/16")
Impacts Per Minute (IPM) Impak Per Minit 冲击数	0 - 4,800
No Load Speed (RPM) Kelajuan Tanpa Beban 回转数	0 - 2,100
Dimensions (L x W x H) Dimensi 体积	285x75x208mm (11-1/4"x3"x8-3/16")
Net Weight Berat Bersih 净重	2.0 - 2.5kg (4.5 - 5.4lbs)
Power Supply Cord Kabel Wayar 电源线	2.5m (8.2ft.)

HR2020 20mm (3/4")

419 WATT

Rotary Hammer Tukul Putar 电锤



- 2-Mode operation for Rotation Only or Hammering with Rotation
Operasi 2-Mod untuk hanya putaran, penukulan dengan putaran sahaja
仅旋转或旋转锤击的双模式操作

Standard Equipment: Side Grip, Depth Gauge



SELESAI stok rasmi ada 售完即止
WHILE STOCK LAST

Continuous Rating Input Input Kuasa Berterusan 额定输入功率	710W
Capacity Kapasiti 能力	Concrete: 20mm (3/4")/ Steel: 13mm (1/2")/ Wood: 32mm (1-1/4")
Impacts Per Minute (IPM) Impak Per Minit 冲击数	0 - 4,050
No Load Speed (RPM) Kelajuan Tanpa Beban 回转数	0 - 1,050
Overall Length Panjang Keseluruhan 总长度	352mm (13-7/8")
Net Weight Berat Bersih 净重	2.3kg (5.1lbs)
Power Supply Cord Kabel Wayar 电源线	4.0m (13.1ft)

HR2320T / X2 23mm (7/8")

325 WATT

Combination Hammer Tukul Kombinasi 电冲击钻锤



- 3-Mode operation; rotation only, hammering with rotation and hammering only
operasi 3 mod: hanya putaran, penukulan dengan putaran, penukulan sahaja
3档模式变换: 仅旋转, 旋转并锤击, 仅锤击

Standard Equipment:
HR2320T: Side Handle, Depth Gauge,
Quick Change Drill Chuck (194079-2)
HR2320TX2: Side Handle, Depth Gauge,
Quick Change Drill Chuck (194079-2),
SDS-Plus Drill & Chisel Set (D-46361)

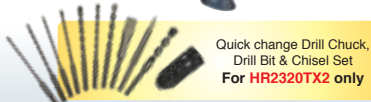

Continuous Rating Input Input Kuasa Berterusan 额定输入功率	720W
Impact Energy Kekuatan Impak 单次最大锤击力	EPTA-Procedure 05/2009: 2.3J Our experimental conditions: 2.6J
Capacity Kapasiti 能力	Concrete: 23mm (7/8")/ Steel: 13mm (1/2")/ Wood: 32mm (1-1/4")
Impacts Per Minute (IPM) Impak Per Minit 冲击数	0 - 4,600
No Load Speed (RPM) Kelajuan Tanpa Beban 回转数	0 - 1,200
Dimensions (L x W x H) Dimensi 体积	380x77x209mm (15"x3"x8-1/4")
Net Weight Berat Bersih 净重	2.9 - 3.2kg (6.4 - 7.0 lbs)
Power Supply Cord Kabel Wayar 电源线	2.5m (8.2 ft)

Cordless
Tangkas Akut 10.8V

LED Flashlight
Lampu Suluh LED
LED照灯

Vacuum Cleaner
Pembersih Vakuum
吸尘器

Drilling / Fastening
Gergaji / Pengikat
电钻 / 螺絲

Impact Drilling / Demolition
Gergaji / Penebuk
冲击电钻 / 电锤

Cutting
Pemotong
切割机

Grinding / Sanding
Pengkilan / Polesan
打磨 / 砂磨

Sawing
Gergaji
电锯

Planing / Routing
Pengkilan / Tanggapan
刨平 / 压花

Others
Lain-lain
其他

Outdoor Power Equipment
Alatan Kuasa Luar
户外动力工具

Makita
100 YEARS

IMPACT DRILLING | DEMOLITION

Cordless
Tangkal Kord Listrik

LED Flashlight
Lampu Senter LED
LED 照灯

Vacuum Cleaner
Pembersih Vakuum
吸尘器

Drilling | Fastening
Overset / Pengingat
扭矩 / 提示

Impact Drilling | Demolition
Overset / Pengingat
扭矩 / 提示

Cutting
Pemotongan
切割

Grinding | Sanding
Pengamiran / Pemoles
打磨 / 抛光

Sawing
Gergaji
锯切

Planing | Routing
Pengamiran / Pengamiran
打磨 / 雕刻

Others
Lain-lain
其他

Outdoor Power Equipment
Alat-alat Tenaga Listrik
器具 / 户外

Makita
Makita

HR2470X5 24mm (15/16") 325 W

Combination Hammer
Tukul Kombinasi
电冲击钻锤

3 modes

3-Mode operation; rotation only, hammering with rotation and hammering only
operasi 3 mod: hanya putaran, penukulan dengan putaran, penukulan sahaja
3档模式变换: 仅旋转, 旋转并锤击, 仅锤击

Standard Equipment: Side Handle, Depth Gauge, Drill Chuck (194041-7), SDS-Plus Bit Set (D-17784), Bull Point (D-08713)

Come with
Drill Chuck 13mm, Drill Bit & Chisel Set

Continuous Rating Input Input Kuasa Berterusan 额定输入功率	780W
Impact Energy Kekuatan Impak 单次最大锤击力	EPTA-Procedure 05/2009: 2.4J Our experimental conditions: 2.7J
Capacity Kapasiti 能力	Concrete: 24mm (15/16")/ Core Bit: 54mm (2-1/8")/ Steel: 13mm (1/2")/ Wood: 32mm (1-1/4")
Impacts Per Minute (IPM) Impak Per Minit 冲击数	0 - 4,500
No Load Speed (RPM) Kelajuan Tanpa Beban 回转数	0 - 1,100
Dimensions (L x W x H) Dimensi 体积	370x84x214mm (14-1/2"x3-5/16"x8-3/8")
Net Weight Berat Bersih 净重	2.9 - 3.3kg (6.4 - 7.3lbs)
Power Supply Cord Kabel Wayar 电源线	4.0m (13.1ft)

HR2631FTX2 26mm (1") 325 W

Combination Hammer
Tukul Kombinasi
电冲击钻锤

3 modes

3-Mode operation; rotation only, hammering with rotation and hammering only
operasi 3 mod: hanya putaran, penukulan dengan putaran, penukulan sahaja
3档模式变换: 仅旋转, 旋转并锤击, 仅锤击

Standard Equipment: Side Handle, Depth Gauge, Quick Change Drill Chuck, SDS-Plus Drill & Chisel Set

Come with
Quick change Drill Chuck, Drill Bit & Chisel Set

Continuous Rating Input Input Kuasa Berterusan 额定输入功率	800W
Impact Energy Kekuatan Impak 单次最大锤击力	EPTA-Procedure 05/2009: 2.4J Our experimental conditions: 2.9J
Capacity Kapasiti 能力	Concrete: 26mm (1")/ Core Bit: 68mm (2-11/16")/ Diamond Core Bit (Dry Type): 80mm (3-1/8")/ Steel: 13mm (1/2") Wood: 32mm (1-1/4")
Impacts Per Minute (IPM) Impak Per Minit 冲击数	0 - 4,600
No Load Speed (RPM) Kelajuan Tanpa Beban 回转数	0 - 1,200
Dimensions (L x W x H) Dimensi 体积	385x77x209mm (15-1/8"x3"x8-1/4")
Net Weight Berat Bersih 净重	3.1 - 3.6kg (6.8 - 7.9lbs)
Power Supply Cord Kabel Wayar 电源线	2.5m (8.2ft)

HR2630X3 26mm (1") 325 W

Combination Hammer
Tukul Kombinasi
电冲击钻锤

3 modes

3-Mode operation; rotation only, hammering with rotation and hammering only
operasi 3 mod: hanya putaran, penukulan dengan putaran, penukulan sahaja
3档模式变换: 仅旋转, 旋转并锤击, 仅锤击

Standard Equipment: Side Handle, Depth Gauge, Drill Chuck, SDS-Plus Drill & Chisel Set

Come with
Drill Chuck 13mm, Drill Bit & Chisel Set

Continuous Rating Input Input Kuasa Berterusan 额定输入功率	800W
Impact Energy Kekuatan Impak 单次最大锤击力	EPTA-Procedure 05/2009: 2.4J Our experimental conditions: 2.9J
Capacity Kapasiti 能力	Concrete: 26mm (1")/ Core Bit: 68mm (2-11/16")/ Diamond Core Bit (Dry Type): 80mm (3-1/8")/ Steel: 13mm (1/2")/ Wood: 32mm (1-1/4")
Impacts Per Minute (IPM) Impak Per Minit 冲击数	0 - 4,600
No Load Speed (RPM) Kelajuan Tanpa Beban 回转数	0 - 1,200
Dimensions (L x W x H) Dimensi 体积	385x77x209mm (15-1/8"x3"x8-1/4")
Net Weight Berat Bersih 净重	2.8 - 3.3kg (6.3 - 7.2lbs)
Power Supply Cord Kabel Wayar 电源线	2.5m (8.2ft)

HR2652 26mm (1") 325 W

Combination Hammer with Self Dust Collection
Tukul Kombinasi dengan Sistem Pengumpulan Habuk
电冲击钻锤与集尘系统

3 modes

See-through dust case for easy checking of collected dust amount
Tahap pengumpulan habuk mudah dilihat dengan kotak habuk lutsinar
透视集尘盒方便检查集尘量

Standard Equipment: Side Grip, Depth Gauge, Sealing Cap

Come with
Drill Chuck 13mm, Drill Bit & Chisel Set

Continuous Rating Input Input Kuasa Berterusan 额定输入功率	800W
Impact Energy Kekuatan Impak 单次最大锤击力	EPTA-Procedure 05/2009: 2.2J Our experimental conditions: 2.9J
Capacity Kapasiti 能力	Concrete: 26mm (1")/ Core Bit: 68mm (2-11/16")/ Diamond Core Bit: 80mm (3-1/8")/ Steel: 13mm (1/2") Wood: 32mm (1-1/4")
Impacts Per Minute (IPM) Impak Per Minit 冲击数	0 - 4,600
No Load Speed (RPM) Kelajuan Tanpa Beban 回转数	0 - 1,200
Dimensions (L x W x H) Dimensi 体积	604x89x260mm (23-3/4"x3-1/2"x10-1/4")
Net Weight Berat Bersih 净重	3 - 4.3kg (6.7 - 9.4lbs.)
Power Supply Cord Kabel Wayar 电源线	2.5m (8.2ft.)

HR2810 28mm (1-1/8") 325 W

Combination Hammer
Tukul Kombinasi
电冲击钻锤

3 modes

3-Mode operation; rotation only, hammering with rotation and hammering only
operasi 3 mod: hanya putaran, penukulan dengan putaran, penukulan sahaja
3档模式变换: 仅旋转, 旋转并锤击, 仅锤击

Standard Equipment: Depth Gauge, Side Grip

Come with
Drill Chuck 13mm, Drill Bit & Chisel Set

Continuous Rating Input Input Kuasa Berterusan 额定输入功率	800W
Impact Energy Kekuatan Impak 单次最大锤击力	EPTA-Procedure 05/2009: 2.8J Our experimental conditions: 2.9J
Capacity Kapasiti 能力	Concrete (T.C.T. bit) : 28mm (1-1/8")/ Steel: 13mm (1/2") Wood: 32mm (1-1/4")
Impacts Per Minute (IPM) Impak Per Minit 冲击数	0 - 4,500
No Load Speed (RPM) Kelajuan Tanpa Beban 回转数	0 - 1,100
Dimensions (L x W x H) Dimensi 体积	314x89x225mm (12-3/8"x3-1/2"x8-7/8")
Net Weight Berat Bersih 净重	3.4 - 3.8kg (7.5 - 8.5lbs)
Power Supply Cord Kabel Wayar 电源线	2.5m (8.2ft)

IMPACT DRILLING | DEMOLITION

HR3011FCJ 30mm (1-3/16")

350 W

Combination Hammer
Tukul Kombinasi
电冲击钻锤



• **3-mode operation for "Rotation Only", "Hammering with Rotation" or "Hammering Only"**
operasi 3 mod: hanya putaran, penukulan dengan putaran, penukulan sahaja
3档模式变换: 仅旋转, 旋转并锤击, 仅锤击



Standard Equipment: Depth Gauge, Side Grip



Continuous Rating Input Input Kuasa Berterusan 额定输入功率	1,050W
Impact Energy Kekuatan Impak 单次最大冲击力	EPTA-Procedure 05/2009: 3.9J Our experimental conditions: 4.5J
Capacity Kapasiti 能力	Concrete (Core Bit): 80mm (3-1/8") Concrete (Diamond Core Bit): 80mm (3-1/8") Concrete (TCT Bit): 30mm (1-3/16") Steel: 13mm (1/2") Wood: 32mm (1-1/4")
Impacts Per Minute (IPM) Impak Per Minit 冲击数	0 - 4500
Dimensions (L x W x H) Dimensi 体积	369x98x242mm (14-1/2x3-7/8x9-1/2")
Net Weight Berat Bersih 净重	4.4 - 4.8kg (9.7 - 10.6lbs.)
Power Supply Cord Kabel Wayar 电源线	4.0m (13.1ft)

HR3001CJ 30mm (1-3/16")

350 W

Combination Hammer
Tukul Kombinasi
电冲击钻锤



• **3-mode operation for "Rotation Only", "Hammering with Rotation" or "Hammering Only"**
operasi 3 mod: hanya putaran, penukulan dengan putaran, penukulan sahaja
3档模式变换: 仅旋转, 旋转并锤击, 仅锤击



Standard Equipment: Depth Gauge, Side Grip



Continuous Rating Input Input Kuasa Berterusan 额定输入功率	1,050W
Impact Energy Kekuatan Impak 单次最大冲击力	EPTA-Procedure 05/2009: 3.9J Our experimental conditions: 4.5J
Capacity Kapasiti 能力	Concrete (Core Bit): 80mm (3-1/8") Concrete (Diamond Core Bit): 80mm (3-1/8") Concrete (TCT Bit): 30mm (1-3/16") Steel: 13mm (1/2") Wood: 32mm (1-1/4")
Impacts Per Minute (IPM) Impak Per Minit 冲击数	0 - 4500
Dimensions (L x W x H) Dimensi 体积	369x98x226mm (14-1/2 x 3-7/8 x 8-7/8")
Net Weight Berat Bersih 净重	4.1 - 4.5kg (9.0 - 9.9lbs.)
Power Supply Cord Kabel Wayar 电源线	4.0m (13.1ft)

HR3210C 32mm (1-1/4")

350 W

Combination Hammer
Tukul Kombinasi
电冲击钻锤



• **3-Mode operation; rotation only, hammering with rotation and hammering only**
operasi 3 mod: hanya putaran, penukulan dengan putaran, penukulan sahaja
3档模式变换: 仅旋转, 旋转并锤击, 仅锤击



Standard Equipment: Depth Gauge, Side Grip, Grease vessel



Continuous Rating Input Input Kuasa Berterusan 额定输入功率	850W
Impact Energy Kekuatan Impak 单次最大冲击力	EPTA-Procedure 05/2009: 5J Our experimental conditions: 5.5J
Capacity Kapasiti 能力	Concrete (T.C.T. bit) : 32mm (1-1/4")/ Steel: 13mm (1/2")/ Wood: 32mm (1-1/4")/ Concrete (Core bit) : 90mm (3-1/2")
Impacts Per Minute (IPM) Impak Per Minit 冲击数	1,650 - 3,300
No Load Speed (RPM) Kelajuan Tanpa Beban 回转数	315 - 630
Dimensions (L x W x H) Dimensi 体积	398x114x239mm (15-5/8"x4-1/2"x9-3/8")
Net Weight Berat Bersih 净重	5.2 - 5.6kg (11.4 - 12.4lbs)
Power Supply Cord Kabel Wayar 电源线	5.0m (16.4ft)

HR3200C 32mm (1-1/4")

350 W

Combination Hammer
Tukul Kombinasi
冲击电钻电锤



• **3-Mode operation; rotation only, hammering with rotation and hammering only**
operasi 3 mod: hanya putaran, penukulan dengan putaran, penukulan sahaja
3档模式变换: 仅旋转, 旋转并锤击, 仅锤击



Standard Equipment: Depth Gauge, Side Grip, Grease Vessel (181573-3)



Continuous Rating Input Input Kuasa Berterusan 额定输入功率	850W
Impact Energy Kekuatan Impak 单次最大冲击力	EPTA-Procedure 05/2009: 5.1J Our experimental conditions: 5.5J
Capacity Kapasiti 能力	Concrete (T.C.T. bit) : 32mm (1-1/4")/ Steel: 13mm (1/2")/ Wood: 32mm (1-1/4")
Impacts Per Minute (IPM) Impak Per Minit 冲击数	1,650 - 3,300
No Load Speed (RPM) Kelajuan Tanpa Beban 回转数	315 - 630
Dimensions (L x W x H) Dimensi 体积	398x108x239mm (15-5/8"x4-1/4"x9-3/8")
Net Weight Berat Bersih 净重	4.8 - 5.2kg (10.5 - 11.5lbs)
Power Supply Cord Kabel Wayar 电源线	5.0m (16.4ft)

HR3530 35mm (1-3/8")

350 W

Rotary Hammer
Tukul Putar
电锤



• **Compact and lightweight design**
Kompak dan ringan
小巧轻便



Standard Equipment: Side Grip, Depth Gauge



Continuous Rating Input Input Kuasa Berterusan 额定输入功率	1,010W
Impact Energy Kekuatan Impak 单次最大冲击力	Our experimental conditions: 6.2J
Capacity Kapasiti 能力	Concrete (T.C.T. bit) : 35mm (1-3/8")/ Concrete (Core bit) : 105mm (4-1/8")
Impacts Per Minute (IPM) Impak Per Minit 冲击数	3,100
No Load Speed (RPM) Kelajuan Tanpa Beban 回转数	760
Dimensions (L x W x H) Dimensi 体积	374x100x243mm (14-3/4"x3-15/16"x9-9/16")
Net Weight Berat Bersih 净重	5.8kg (12.8lbs)
Power Supply Cord Kabel Wayar 电源线	5.0m (16.4ft)

Cordless
Tempa Kord 无线式

LED Flashlight
Lampu Suka LED
LED照明灯

Vacuum Cleaner
Pembersih Vakuam
吸尘器

Drilling / Fastening
Guaah / Pengikat
钻孔 / 紧固

Impact Drilling / Demolition
Guaah / Pengikat
冲击钻孔 / 拆除

Cutting
Pemotong
切割

Grinding / Sanding
Pengkilan / Pasukan
打磨 / 打磨

Sawing
Guaah
锯切

Planing / Routing
Pengkilan / Trajangan
刨削 / 刨削

Others
Lain-lain
其他

Outdoor Power Equipment
Alatan Kuasa Luar
户外动力工具

Makita
1915

IMPACT DRILLING | DEMOLITION

Cordless
Tangkapan Kuasa Berterusan

LED Flashlight
Lampu Sorot LED
LED 燈射射

Vacuum Cleaner
Penyerap Vakuum
真空吸

Drilling | Fastening
Gergaji | Pengikat
钻孔 | 固定

Impact Drilling | Demolition
Gergaji | Pemecah
冲击钻孔 | 拆除加工

Cutting
Pemotong
切割

Grinding | Sanding
Pengamiran | Poles
打磨 | 磨光

Sawing
Gergaji
锯切

Planing | Routing
Pengamiran | Tengkingan
磨削 | 磨削

Others
Lain-lain
其他

Outdoor Power Equipment
Alat Kuasa Luar
户外动力设备

Makita
MAKITA

HR4001C 40mm (1-9/16") 350

Rotary Hammer
Tukul Putar
电锤



• **Precision machined, all metal gears with more surface contact for more power**
Pemesanan ketepatan, gear semua logam, lebih banyak sentuhan permukaan, lebih kuasa
精密加工, 全金属齿轮, 表面接触更多, 功率更大

Standard Equipment: Depth Gauge, Side Grip, Grease vessel

WHILE STOCK LAST

Continuous Rating Input Input Kuasa Berterusan 额定输入功率	1,100W
Impact Energy Kekuatan Impak 单次最大锤击力	EPTA-Procedure 05/2009: 6.8J Our experimental conditions: 9.5J
Capacity Kapasiti 能力	Concrete (T.C.T. bit): 40mm (1-9/16")/ Concrete (Core bit): 105mm (4-1/8")
Impacts Per Minute (IPM) Impak Per Minit 冲击数	1,350-2,750
No Load Speed (RPM) Kelajuan Tanpa Beban 回转数	235-480
Dimensions (L x W x H) Dimensi 体积	468x106x261mm (18-1/2"x4-3/16"x10-1/4")
Net Weight Berat Bersih 净重	5.9kg (13.0lbs)
Power Supply Cord Kabel Wayar 电源线	5.0m (16.4ft)

HR4002 40mm (1-9/16") 350

Rotary Hammer
Tukul Putar
电锤



• **No hammering when idling increases the tool life and performance**
Tiada penukul semasa melahau, meningkatkan hayat alat dan prestasi
空转时不会锤击, 提升了工具的使用寿命和性能

Standard Equipment: Side Grip, Bit Grease, Depth Gauge

Continuous Rating Input Input Kuasa Berterusan 额定输入功率	1,050W
Impact Energy Kekuatan Impak 单次最大锤击力	EPTA-Procedure 05/2009: 6.1J Our experimental conditions: 6.2J
Capacity Kapasiti 能力	Concrete (T.C.T. bit) : 40mm (1-9/16")/ Concrete (Core bit) : 105mm (4-1/8")
Impacts Per Minute (IPM) Impak Per Minit 冲击数	2,500
No Load Speed (RPM) Kelajuan Tanpa Beban 回转数	680
Dimensions (L x W x H) Dimensi 体积	458x114x256mm (18"x4-1/2 "x10-1/8")
Net Weight Berat Bersih 净重	6.6 - 6.8kg (14.6 - 15.0lbs)
Power Supply Cord Kabel Wayar 电源线	5.0m (16.4ft)

HR4003C 40mm (1-9/16") 350

Rotary Hammer
Tukul Putar
电锤





• **Soft start suppresses start-up reaction for more control and better accuracy**
Permulaan lembut untuk lebih kawalan dan ketepatan lebih baik
轻启动以获得更多控制和更精准

Standard Equipment: Depth Gauge, Side Handle, Bit Grease, Cloth

Continuous Rating Input Input Kuasa Berterusan 额定输入功率	1,100W
Impact Energy Kekuatan Impak 单次最大锤击力	EPTA-Procedure 05/2009: 8.3J Our experimental conditions: 11.4J
Capacity Kapasiti 能力	Concrete (T.C.T. bit) : 40mm (1-9/16")/ Concrete (Core bit) : 105mm (4-1/8")
Impacts Per Minute (IPM) Impak Per Minit 冲击数	1,450 - 2,900
No Load Speed (RPM) Kelajuan Tanpa Beban 回转数	250 - 500
Dimensions (L x W x H) Dimensi 体积	479x106x263mm (18-11/16"x4-3/16"x10-3/8")
Net Weight Berat Bersih 净重	6.2 - 6.4kg (13.7 - 14.1lbs)
Power Supply Cord Kabel Wayar 电源线	5.0m (16.4ft)

HR4013C 40mm (1-9/16") 350

Rotary Hammer
Tukul Putar
电锤

• **Soft start suppresses start-up reaction for more control and better accuracy**
Permulaan lembut untuk lebih kawalan dan ketepatan lebih baik
轻启动以获得更多控制和更精准

Standard Equipment: Depth Gauge, Side Handle (D), Side Grip, Bit Grease, Cloth

AVT SOFT NOLOAD

Continuous Rating Input Input Kuasa Berterusan 额定输入功率	1,100W
Impact Energy Kekuatan Impak 单次最大锤击力	EPTA-Procedure 05/2009: 8J Our experimental conditions: 11.4J
Capacity Kapasiti 能力	Concrete (T.C.T. bit) : 40mm (1-9/16")/ Concrete (Core bit) : 105mm (4-1/8")
Impacts Per Minute (IPM) Impak Per Minit 冲击数	1,450 - 2,900
No Load Speed (RPM) Kelajuan Tanpa Beban 回转数	250 - 500
Dimensions (L x W x H) Dimensi 体积	479x112x263mm (18-11/16"x4-3/8"x10-3/8")
Net Weight Berat Bersih 净重	6.8 - 6.9kg (14.9 - 15.3lbs)
Power Supply Cord Kabel Wayar 电源线	5.0m (16.4ft)

HR4030C 40mm (1-9/16") 350

Rotary Hammer
Tukul Putar
电锤



• **No hammering when idling increases the tool life and performance**
Tiada penukul semasa melahau, meningkatkan hayat alat dan prestasi
空转时不会锤击, 提升了工具的使用寿命和性能

Standard Equipment: Depth Gauge, Side Grip

Continuous Rating Input Input Kuasa Berterusan 额定输入功率	1,100W
Impact Energy Kekuatan Impak 单次最大锤击力	Our experimental conditions: 9.2J
Capacity Kapasiti 能力	Concrete (T.C.T. bit) : 40mm (1-9/16")/ Concrete (Core bit) : 118mm (4-5/8")
Impacts Per Minute (IPM) Impak Per Minit 冲击数	1,300 - 2,600
No Load Speed (RPM) Kelajuan Tanpa Beban 回转数	230 - 460
Dimensions (L x W x H) Dimensi 体积	413x107x247mm (16-1/4"x4-1/4"x9-3/4")
Net Weight Berat Bersih 净重	6.9kg (15.2lbs)
Power Supply Cord Kabel Wayar 电源线	5.0m (16.4ft)

IMPACT DRILLING | DEMOLITION

HR4501C 45mm (1-3/4")

175

Rotary Hammer Tukul Putar 电锤



- **High performance and durability**
Prestasi dan ketahanan tinggi
高性能兼耐用

Standard Equipment: Side Handle (D), Side Grip, Depth Gauge, Grease Vessel, Cloth



HR4511C 45mm (1-3/4")

175

Rotary Hammer Tukul Putar 电锤



- **High performance and low vibration**
Prestasi tinggi dan getaran rendah
高性能和低振动

Standard Equipment: Side handle (D), Side Grip, Depth Gauge, Grease Vessel, Cloth

AVT

HR5202C 52mm (2-1/16")

175

Rotary Hammer Tukul Putar 电锤



- **Soft start suppresses start-up reaction for more control and better accuracy**
Permulaan lembut untuk lebih kawalan dan ketepatan lebih baik
轻启动以获得更多控制和更精准

Standard Equipment: Side handle (D), Side Grip, Depth Gauge, Grease Vessel, Cloth



HR5211C 52mm (2-1/16")

175

Rotary Hammer Tukul Putar 电锤



- **High performance and low vibration**
Prestasi tinggi dan getaran rendah
高性能和低振动

Standard Equipment: Side handle (D), Side Grip, Depth Gauge, Grease Vessel

AVT

HR5212C 52mm (2-1/16")

175

Rotary Hammer Tukul Putar 电锤



- **Soft start suppresses start-up reaction for more control and better accuracy**
Permulaan lembut untuk lebih kawalan dan ketepatan lebih baik
轻启动以获得更多控制和更精准

Standard Equipment: Side Handle, Side Grip, Depth Gauge, Grease Vessel, Cloth

AVT SOFT NO LOAD

Continuous Rating Input 1,350W

Input Kuasa Berterusan 额定输入功率

Impact Energy EPTA-Procedure 05/2009: 10.1J
Kekuatan Impak 单次最大锤击力 Our experimental conditions: 12.5J

Capacity Concrete (T.C.T. bit) : 45mm (1-3/4")/
Kapasiti 能力 Concrete (Core bit) : 125mm (5")

Impacts Per Minute (IPM) 1,250 - 2,750
Impak Per Minit 冲击数

No Load Speed (RPM) 130 - 280
Kelajuan Tanpa Beban 回转数

Dimensions (L x W x H) 458x121x288mm
Dimensi 体积 (18"x4-3/4"x11-3/8")

Net Weight 8.2 - 8.4kg (18.1 - 18.5lbs)
Berat Bersih 净重

Power Supply Cord 5.0m (16.4ft)
Kabel Wayar 电源线

Continuous Rating Input 1,350W

Input Kuasa Berterusan 额定输入功率

Impact Energy EPTA-Procedure 05/2009: 9.4J
Kekuatan Impak 单次最大锤击力 Our experimental conditions: 12.5J

Capacity Concrete (T.C.T. bit) : 45mm (1-3/4")/
Kapasiti 能力 Concrete (Core bit) : 125mm (5")

Impacts Per Minute (IPM) 1,250 - 2,750
Impak Per Minit 冲击数

No Load Speed (RPM) 130 - 280
Kelajuan Tanpa Beban 回转数

Dimensions (L x W x H) 458x136x288mm
Dimensi 体积 (18"x5-3/8"x11-3/8")

Net Weight 9.0 - 9.1kg (19.8 - 20.1lbs)
Berat Bersih 净重

Power Supply Cord 5.0m (16.4ft)
Kabel Wayar 电源线

Continuous Rating Input 1,510W

Input Kuasa Berterusan 额定输入功率

Impact Energy EPTA-Procedure 05/2009: 19.1J
Kekuatan Impak 单次最大锤击力 Our experimental conditions: 21J

Capacity Concrete (T.C.T. bit) : 52mm (2")/
Kapasiti 能力 Concrete (Core bit) : 160mm (6-5/16")

Impacts Per Minute (IPM) 1,100 - 2,250
Impak Per Minit 冲击数

No Load Speed (RPM) 150 - 310
Kelajuan Tanpa Beban 回转数

Dimensions (L x W x H) 599x134x287mm
Dimensi 体积 (23-1/2"x5-1/4"x11-1/4")

Net Weight 10.9 - 11.1kg (24.1 - 24.4lbs)
Berat Bersih 净重

Power Supply Cord 5.0m (16.4ft)
Kabel Wayar 电源线

Continuous Rating Input 1,500W

Input Kuasa Berterusan 额定输入功率

Impact Energy EPTA-Procedure 05/2009: 18.9J
Kekuatan Impak 单次最大锤击力 Our experimental conditions: 20J

Capacity Concrete (T.C.T. bit) : 52mm (2")/
Kapasiti 能力 Concrete (Core bit) : 160mm (6-1/4")

Impacts Per Minute (IPM) 1,075 - 2,150
Impak Per Minit 冲击数

No Load Speed (RPM) 130 - 260
Kelajuan Tanpa Beban 回转数

Dimensions (L x W x H) 599x149x287mm
Dimensi 体积 (23-1/2"x5-7/8"x11-1/4")

Net Weight 12.2kg (26.8lbs)
Berat Bersih 净重

Power Supply Cord 5.0m (16.4ft)
Kabel Wayar 电源线

Continuous Rating Input 1,510W

Input Kuasa Berterusan 额定输入功率

Impact Energy EPTA-Procedure 05/2009: 20J
Kekuatan Impak 单次最大锤击力 Our experimental conditions: 21J

Capacity Concrete (T.C.T. bit) : 52mm (2")/
Kapasiti 能力 Concrete (Core bit) : 160mm (6-5/16")

Impacts Per Minute (IPM) 1,100 - 2,250
Impak Per Minit 冲击数

No Load Speed (RPM) 150 - 310
Kelajuan Tanpa Beban 回转数

Dimensions (L x W x H) 599x140x287mm
Dimensi 体积 (23-1/2"x5-1/2"x11-1/4")

Net Weight 11.9 - 12.0kg (26.2 - 26.5lbs)
Berat Bersih 净重

Power Supply Cord 5.0m (16.4ft)
Kabel Wayar 电源线

Cordless
Tempa Kord 充电式

LED Flashlight
Lampu Suluh LED
LED照明灯

Vacuum Cleaner
Pembersih Vakuam
吸尘器

Drilling / Fastening
Cairan / Pengikat
钻孔 / 紧固

Impact Drilling / Demolition
Ganda / Penebuk
冲击钻孔 / 拆除施工

Cutting
Pemotong
切割

Grinding / Sanding
Pengkilan / Palsan
打磨 / 砂磨

Sawing
Cergas
锯切

Planing / Routing
Pegolan / Tanggam
刨削 / 雕刻

Others
Lain-lain
其他

Outdoor Power Equipment
Alatan Kerja Luar
户外动力设备

Makita
1915

IMPACT DRILLING | DEMOLITION

HM0810TA 17mm (11/16") Hex Shank

105 **MM**

Demolition Hammer Pemahat Tukul Elektrik 电动槌



- **Ideal for light chiseling, chipping and scaling operations**
Sesuai untuk operasi ringan untuk pahatan, penyerpihan dan perskalaan
适用于轻凿击，碎击和铲除原有表面等操作

Standard Equipment: Bull Point, Hex Wrench, Side Grip



Continuous Rating Input Input Kuasa Berterusan 额定输入功率	900W
Impact Energy Kekuatan Impak 单次最大锤击力	EPTA-Procedure 05/2009: 7.2J Our experimental conditions: 7.6J
Impacts Per Minute (IPM) Impak Per Minit 冲击数	2,900
Overall Length Panjang Keseluruhan 总长度	428mm (16-7/8")
Net Weight Berat Bersih 净重	6.3kg (13.9lbs)
Power Supply Cord Kabel Wayar 电源线	5.0m (16.4ft)

HM0870C

350 **MM**

Demolition Hammer Pemahat Tukul Elektrik 电动槌



- **Compact Power with Less Weight**
Kompak dan ringan
紧凑更重

Standard Equipment: Grease for bit, Side Handle, Cloth



Continuous Rating Input Input Kuasa Berterusan 额定输入功率	1,100W
Impact Energy Kekuatan Impak 单次最大锤击力	EPTA-Procedure 05/2009: 7.6J Our experimental conditions: 11.4J
Impacts Per Minute (IPM) Impak Per Minit 冲击数	1,100 - 2,650
Dimensions (L x W x H) Dimensi 体积	449x109x230mm (17-3/4"x4-1/4"x9")
Net Weight Berat Bersih 净重	5.1 - 5.3kg (11.1 - 11.6lbs)
Power Supply Cord Kabel Wayar 电源线	5.0m (16.4ft)

HM0871C

350 **MM**

Demolition Hammer Pemahat Tukul Elektrik 电动槌



- **High durability and excellent demolition performance**
Ketahanan dan prestasi yang tinggi
高耐用性

Standard Equipment: Grease for bit, Side Handle, Cloth



AVT SOFT NOLOAD

Continuous Rating Input Input Kuasa Berterusan 额定输入功率	1,100W
Impact Energy Kekuatan Impak 单次最大锤击力	EPTA-Procedure 05/2009: 8.1J Our experimental conditions: 11.6J
Impacts Per Minute (IPM) Impak Per Minit 冲击数	1,100 - 2,650
Dimensions (L x W x H) Dimensi 体积	466x116x230mm (18-3/8"x4-9/16"x9")
Net Weight Berat Bersih 净重	5.6 - 5.8kg (12.4 - 12.8lbs)
Power Supply Cord Kabel Wayar 电源线	5.0m (16.4ft)

HM1201 21mm (13/16") Hex Shank

155 **MM**

Demolition Hammer Pemahat Tukul Elektrik 电动槌



- **Powerful impact from durable aluminum body**
Tahan lama dan berkuasa
耐用铝合金机身提供强大的冲击力

Standard Equipment: Bull Point, Hex Wrench, Side Grip



Continuous Rating Input Input Kuasa Berterusan 额定输入功率	1,130W
Impact Energy Kekuatan Impak 单次最大锤击力	Our experimental conditions: 13J
Impacts Per Minute (IPM) Impak Per Minit 冲击数	2,000
Overall Length Panjang Keseluruhan 总长度	480mm (18-7/8")
Net Weight Berat Bersih 净重	9.1kg (20.1lbs)
Power Supply Cord Kabel Wayar 电源线	5.0m (16.4ft)

HM1213C

175 **MM**

Demolition Hammer Pemahat Tukul Elektrik 电动槌



- **Vibration absorbing handle provides comfortable operation**
Pemegang menyerap getaran untuk operasi yang selesa
吸振手柄提供舒适的操作

Standard Equipment: Bull Point, Bit Grease, Side Handle, Cloth



AVT SOFT NOLOAD

Continuous Rating Input Input Kuasa Berterusan 额定输入功率	1,510W
Impact Energy Kekuatan Impak 单次最大锤击力	EPTA-Procedure 05/2009: 18.6J Our experimental conditions: 25.5J
Impacts Per Minute (IPM) Impak Per Minit 冲击数	950 - 1,900
Dimensions (L x W x H) Dimensi 体积	576x149x265mm (22-3/4"x5-7/8"x10-3/8")
Net Weight Berat Bersih 净重	10.8kg (23.7lbs)
Power Supply Cord Kabel Wayar 电源线	5.0m (16.4ft)

IMPACT DRILLING | DEMOLITION

HM1203C

175

Demolition Hammer Pemahat Tukul Elektrik 电动槌



- **Increasing energy transfer for more power**
Meningkatkan pemindahan tenaga untuk lebih banyak kuasa
增加能量传递以获得更多电力

Standard Equipment: Bull Point, Bit Grease, Side Handle



Continuous Rating Input Input Kuasa Berterusan 额定输入功率	1,510W
Impact Energy Kekuatan Impak 单次最大冲击力	EPTA-Procedure 05/2009: 19.1J Our experimental conditions: 25.5J
Impacts Per Minute (IPM) Impak Per Minit 冲击数	950 - 1,900
Dimensions (L x W x H) Dimensi 体积	576x128x265mm (22-3/4"x5"x10-3/8")
Net Weight Berat Bersih 净重	9.7kg (21.5lbs)
Power Supply Cord Kabel Wayar 电源线	5.0m (16.4ft)

HM1214C

175

Demolition Hammer Pemahat Tukul Elektrik 电动槌



- **Powerful 1,510W motor**
Motor berkuasa 1,510W
强大马达1,510W

Standard Equipment: Bull Point, Bit Grease, Side Handle, Cloth



AVT SOFT NOLOAD

Continuous Rating Input Input Kuasa Berterusan 额定输入功率	1,510W
Impact Energy Kekuatan Impak 单次最大冲击力	EPTA-Procedure 05/2009: 19.9J Our experimental conditions: 26J
Impacts Per Minute (IPM) Impak Per Minit 冲击数	950 - 1,900
Dimensions (L x W x H) Dimensi 体积	700x129x265mm (27-1/2"x5-1/8"x10-3/8")
Net Weight Berat Bersih 净重	12.3kg (27.1lbs)
Power Supply Cord Kabel Wayar 电源线	5.0m (16.4ft)

HM1306 30mm (1-3/16") Hex Shank

204

Demolition Hammer Pemahat Tukul Elektrik 电动槌



- **Powerful 1,510W motor**
Motor berkuasa 1,510W
强大马达1,510W

Standard Equipment: Bull Point, Wrench, Side Handle,
Oil Supply 100ml



Continuous Rating Input Input Kuasa Berterusan 额定输入功率	1,510W
Impact Energy Kekuatan Impak 单次最大冲击力	EPTA-Procedure 05/2009: 21.7J Our experimental conditions: 28.8J
Impacts Per Minute (IPM) Impak Per Minit 冲击数	1,450
Dimensions (L x W x H) Dimensi 体积	652x121x231mm (25-3/4"x4-3/4"x9-1/8")
Net Weight Berat Bersih 净重	15.1kg (33.3lbs)
Power Supply Cord Kabel Wayar 电源线	5.0m (16.4ft)

HM1317C 30mm (1-3/16") Hex Shank

175

Electric Breaker Tukul Elektrik 电动槌



- **High durability and excellent demolition performance**
Ketahanan dan berprestasi tinggi
高耐用性

Standard Equipment: Side Handle



AVT SOFT NOLOAD

Continuous Rating Input Input Kuasa Berterusan 额定输入功率	1,510W
Impact Energy Kekuatan Impak 单次最大冲击力	EPTA-Procedure 05/2009: 25 (100-127 V: 21) J Our experimental conditions: 33.8 J
Impacts Per Minute (IPM) Impak Per Minit 冲击数	730 - 1,450
Dimensions (L x W x H) Dimensi 体积	715x129x266mm (28-1/8"x5-1/8"x10-1/2")
Net Weight Berat Bersih 净重	17kg (37.5lbs)
Power Supply Cord Kabel Wayar 电源线	5.0m (16.4ft)

HM1307C 30mm (1-3/16") Hex Shank

175

Electric Breaker Tukul Elektrik 电动槌



- **Electronic Controller for Operator Convenience**
Kawalan Elektronik memudahkan pengguna
电子控制方便使用

Standard Equipment: Side Handle, Bull Point



Continuous Rating Input Input Kuasa Berterusan 额定输入功率	1,510W
Impact Energy Kekuatan Impak 单次最大冲击力	EPTA-Procedure 05/2009: 25.5J Our experimental conditions: 33.8J
Impacts Per Minute (IPM) Impak Per Minit 冲击数	730 - 1,450
Dimensions (L x W x H) Dimensi 体积	715x129x266mm (28-1/8"x5-1/8"x10-1/2")
Net Weight Berat Bersih 净重	15.3kg (33.8lbs)
Power Supply Cord Kabel Wayar 电源线	5.0m (16.4ft)

Cordless
Terasa Keras 08/08

LED Flashlight
Lampu Suluhi LED
LED照灯

Vacuum Cleaner
Pembersih Vakuum
吸尘器

Drilling / Fastening
Cepat / Pengikat
钻孔 / 紧固

Impact Drilling / Demolition
Cepat / Pemusnah
冲击钻孔 / 拆除施工

Cutting
Pemotong
切割

Grinding / Sanding
Pengisar / Pasir
打磨 / 砂磨

Sawing
Cepat
锯切

Planing / Routing
Pengaliran / Tumpang
刨削 / 雕刻

Others
Lain-lain
其他

Outdoor Power Equipment
Alatan Kerja Luar
户外动力设备

Makita
1915

IMPACT DRILLING | DEMOLITION

Cordless
Tahan Kord Listrik

LED Flashlight
Lampu Suhu LED
LED 燈射射

Vacuum Cleaner
Pembersih Vakuum
吸尘器

Drilling | Fastening
Gali / Pasang
钻孔 / 紧固

Impact Drilling | Demolition
Gali / Pecahkan
石工钻孔 / 拆毁加工

Cutting
Pemotongan
切割

Grinding | Sanding
Penghalus / Pasah
打磨 / 磨

Sawing
Gergaji
锯切

Planing | Routing
Penghalus / Tergam
磨削 / 磨削

Others
Lain-lain
其他

Outdoor Power Equipment
Alat-alat Tenaga Luar
園林-戶外

Makita
Makita

HM1501 30mm (1-3/16") Hex Shank

218

Electric Breaker

Tukul Kombinasi
电冲击钻锤

Both drastically increased power and low vibration are achieved with minimum increase in tool size and weight

Mencapai peningkatan daya yang kuat dan getaran rendah dengan ukuran alat dan berat yang terkecil
以最小的工具尺寸和重量增加实现了功率的急剧增加和低振动



Standard Equipment: Side Handle, Bull Point



Continuous Rating Input Input Kuasa Berterusan 额定输入功率	1,850W
Impact Energy Kekuatan Impak 单次最大冲击力	EPTA-Procedure 05/2009: 48.1J
Impacts Per Minute (IPM) Impak Per Minit 冲击数	1,300
Dimensions (L x W x H) Dimensi 体积	781x130x266mm (30-3/4x5-1/8x10-1/2")
Net Weight Berat Bersih 淨重	18.4kg (40.6lbs.)
Power Supply Cord Kabel Wayar 电源线	5.0m (16.4ft)

HM1511 30mm (1-3/16") Hex Shank

218

Electric Breaker

Tukul Kombinasi
电冲击钻锤

Both drastically increased power and low vibration are achieved with minimum increase in tool size and weight

Mencapai peningkatan daya yang kuat dan getaran rendah dengan ukuran alat dan berat yang terkecil
以最小的工具尺寸和重量增加实现了功率的急剧增加和低振动



Standard Equipment: Side Handle, Bull Point



Continuous Rating Input Input Kuasa Berterusan 额定输入功率	1,850W
Impact Energy Kekuatan Impak 单次最大冲击力	EPTA-Procedure 05/2009: 48.9J
Impacts Per Minute (IPM) Impak Per Minit 冲击数	1,300
Dimensions (L x W x H) Dimensi 体积	781x130x266mm (30-3/4x5-1/8x10-1/2")
Net Weight Berat Bersih 淨重	19.2kg (42.3lbs.)
Power Supply Cord Kabel Wayar 电源线	5.0m (16.4ft)

HM1810 28.6mm (1-1/8") Hex Shank

204

Electric Breaker

Tukul Elektrik
电动链

Powerful 2,000W motor
Motor berkuasa 2,000W
强大马达2,000W



Sambleta stok masih ada 售完即止
WHILE STOCK LAST



Standard Equipment: Hex Wrench



Continuous Rating Input Input Kuasa Berterusan 额定输入功率	2,000W
Impact Energy Kekuatan Impak 单次最大冲击力	EPTA-Procedure 05/2009: 44.9J Our experimental conditions: 63J
Impacts Per Minute (IPM) Impak Per Minit 冲击数	1,100
Dimensions (L x W x H) Dimensi 体积	824x146x633mm (32-1/2"x5-3/4"x25")
Net Weight Berat Bersih 淨重	32.0kg (70.6lbs)
Power Supply Cord Kabel Wayar 电源线	5.0m (16.4ft)

HM1812 28.6mm (1-1/8") Hex Shank

218

Electric Breaker

Tukul Elektrik
电动链

Hits like air without the vibration
Tukulan mudah
轻易链击



Standard Equipment: Bull Point, Hex Wrench



Continuous Rating Input Input Kuasa Berterusan 额定输入功率	2,000W
Impact Energy Kekuatan Impak 单次最大冲击力	EPTA-Procedure 05/2009: 72.8J Our experimental conditions: 62J
Impacts Per Minute (IPM) Impak Per Minit 冲击数	870
Dimensions (L x W x H) Dimensi 体积	843x210x608mm (33-1/4"x8-1/4"x24")
Net Weight Berat Bersih 淨重	31.3kg (69lbs)
Power Supply Cord Kabel Wayar 电源线	5.0m (16.4ft)

HK1820

350

Power Scraper

Pengikis Elektrik
电动刮剥机

Large trigger switch with variable speed control function

Suis pencetus yang besar dengan fungsi kawalan kelajuan
备用变速控制功能的大型触发开关



Standard Equipment: Bull Point, Scaling Chisel, Scaling chisel (for tile), Hook complete



Continuous Rating Input Input Kuasa Berterusan 额定输入功率	550W
Impact Energy Kekuatan Impak 单次最大冲击力	EPTA-Procedure 05/2009: 3.1J Our experimental conditions: 3.9J
Impacts Per Minute (IPM) Impak Per Minit 冲击数	0 - 3,200
Dimensions (L x W x H) Dimensi 体积	351x102x203mm (13-3/4"x4"x8")
Net Weight Berat Bersih 淨重	3.4kg (7.5lbs)
Power Supply Cord Kabel Wayar 电源线	5.0m (16.4ft)



Combination / Rotary Hammer Drill Capability Chart

Jadual keupayaan gerudi 钻孔能力表

■ Tungsten Carbide-tipped usable range

■ Recommended range

■ Core bits



Optimal



Possible

		Impact energy according to EPTA05/2009: J	EPTA Weight (kg)	Impact energy scale (0-160 J)																MATERIAL FOR DRILLING			
Series	Model			0	10	20	30	40	50	60	70	80	90	100	110	120	130	140	150	160	Highly reinforced concrete	Concrete, granite, stone, brick	Metal/wood
14mm series	HR140D	1.0J	1.9 - 2.6	3.2-14 3.2-10																✓	✓✓✓	✓	↕
	SDS-plus																						

		Impact energy according to EPTA05/2009: J	EPTA Weight (kg)	Impact energy scale (0-160 J)																MATERIAL FOR DRILLING			
Series	Model			0	10	20	30	40	50	60	70	80	90	100	110	120	130	140	150	160	Highly reinforced concrete	Concrete, granite, stone, brick	Metal/wood
16mm series	DHR165	1.3J	2.3 - 3.0	3.2-16 3.2-10																✓	✓✓✓	✓	↕
	SDS-plus																						
16mm series	HR166D	1.1J	1.8 - 2.4	3.2-16 3.2-10																✓	✓✓✓	✓	↕
	SDS-plus																						

		Impact energy according to EPTA05/2009: J	EPTA Weight (kg)	Impact energy scale (0-160 J)																MATERIAL FOR DRILLING			
Series	Model			0	10	20	30	40	50	60	70	80	90	100	110	120	130	140	150	160	Highly reinforced concrete	Concrete, granite, stone, brick	Metal/wood
17mm series	DHR171	1.2J	2.1 - 2.8	3.2-17 3.2-10																✓	✓✓✓	✓	↕
	SDS-plus																						

		Impact energy according to EPTA05/2009: J	EPTA Weight (kg)	Impact energy scale (0-160 J)																MATERIAL FOR DRILLING			
Series	Model			0	10	20	30	40	50	60	70	80	90	100	110	120	130	140	150	160	Highly reinforced concrete	Concrete, granite, stone, brick	Metal/wood
18mm series	DHR182	1.7J	2.4 - 3.2	3.2-18 3.2-10																✓	✓✓✓	✓	↕
	SDS-plus																						
18mm series	HR1841F	1.4J	2.0 - 2.5	3.2-18 3.2-10																✓	✓✓✓	✓	↕
	SDS-plus																						
18mm series	HR1840	1.4J	2.0 - 2.5	3.2-18 3.2-10																✓	✓✓✓	✓	↕
	SDS-plus																						
18mm series	HR1830	1.2J	1.9	3.2-18 3.2-10																✓	✓✓✓	✓	↕
	SDS-plus																						

		Impact energy according to EPTA05/2009: J	EPTA Weight (kg)	Impact energy scale (0-160 J)																MATERIAL FOR DRILLING			
Series	Model			0	10	20	30	40	50	60	70	80	90	100	110	120	130	140	150	160	Highly reinforced concrete	Concrete, granite, stone, brick	Metal/wood
20mm series	DHR202	1.9J	3.2 - 4.0	3.2-20 4-12																✓	✓✓✓	✓	↕
	SDS-plus																						
20mm series	DHR241	1.9J	3.2 - 4.0	3.2-20 4-12																✓	✓✓✓	✓	↕
	SDS-plus																						
20mm series	HR2020	2.2J	2.6	3.2-20 4-12																✓	✓✓✓	✓	↕
	SDS-plus																						

		Impact energy according to EPTA05/2009: J	EPTA Weight (kg)	Impact energy scale (0-160 J)																MATERIAL FOR DRILLING			
Series	Model			0	10	20	30	40	50	60	70	80	90	100	110	120	130	140	150	160	Highly reinforced concrete	Concrete, granite, stone, brick	Metal/wood
23mm series	HR2320T	2.3J	2.9 - 3.2	3.2-23 4-15																✓	✓✓✓	✓	↕
	SDS-plus																						

		Impact energy according to EPTA05/2009: J	EPTA Weight (kg)	Impact energy scale (0-160 J)																MATERIAL FOR DRILLING			
Series	Model			0	10	20	30	40	50	60	70	80	90	100	110	120	130	140	150	160	Highly reinforced concrete	Concrete, granite, stone, brick	Metal/wood
24mm series	DHR242	2.0J	3.1 - 3.8	3.2-24 4-16																✓	✓✓✓	✓	↕
	SDS-plus																						
24mm series	HR2470	2.4J	2.9 - 3.3	3.2-24 4-16																✓	✓✓✓	✓	↕
	SDS-plus																						

		Impact energy according to EPTA05/2009: J	EPTA Weight (kg)	Impact energy scale (0-160 J)																MATERIAL FOR DRILLING			
Series	Model			0	10	20	30	40	50	60	70	80	90	100	110	120	130	140	150	160	Highly reinforced concrete	Concrete, granite, stone, brick	Metal/wood
26mm series	DHR263	2.5J	4.1 - 5.1	3.2-26 4-18																✓	✓✓✓	✓	↕
	SDS-plus																						
26mm series	HR2652	2.2J	3.0 - 4.3	3.2-26 4-18																✓	✓✓✓	✓	↕
	SDS-plus																						
26mm series	HR2631FT	2.4J	2.8 - 3.5	3.2-26 4-18																✓	✓✓✓	✓	↕
	SDS-plus																						
26mm series	HR2630	2.4J	2.8 - 3.5	3.2-26 4-18																✓	✓✓✓	✓	↕
	SDS-plus																						

		Impact energy according to EPTA05/2009: J	EPTA Weight (kg)	Impact energy scale (0-160 J)																MATERIAL FOR DRILLING				
Series	Model			0	10	20	30	40	50	60	70	80	90	100	110	120	130	140	150	160	Highly reinforced concrete	Concrete, granite, stone, brick	Metal/wood	Working direction
28mm series	DHR280	2.8J	3.9 - 5.0	3.2-28 6-20 35-54																Diamond core 32 ~ 65 (dry type)	✓	✓✓✓	✓	↕
	SDS-plus			✓	✓✓✓	✓																		
28mm series	DHR282	2.8J	3.9 - 4.9	3.2-28 6-20 35-54																Diamond core 32 ~ 65 (dry type)	✓	✓✓✓	✓	↕
	SDS-plus			✓	✓✓✓	✓																		
28mm series	HR001G HR003G	2.8J	3.9 - 4.6	3.2-28 6-20 35-54																Diamond core 32 ~ 65 (dry type)	✓	✓✓✓	✓	↕
	SDS-plus			✓	✓✓✓	✓																		
28mm series	HR002G	2.9J	4.1 - 4.6	3.2-28 6-20 35-54																Diamond core 32 ~ 65 (dry type)	✓	✓✓✓	✓	↕
	SDS-plus			✓	✓✓✓	✓																		
28mm series	HR2810	2.9J	3.4 - 3.9	3.2-28 6-20 35-80																Diamond core 32 ~ 80 (dry type)	✓	✓✓✓	✓	↕
	SDS-plus			✓	✓✓✓	✓																		
28mm series	HR007G	3.0J	3.8 - 4.8	3.2-28 6-20 35-54																Diamond core 32 ~ 65 (dry type)	✓	✓✓✓	✓	↕
	SDS-plus			✓	✓✓✓	✓																		

		Impact energy according to EPTA05/2009: J	EPTA Weight (kg)	Impact energy scale (0-160 J)																MATERIAL FOR DRILLING				
Series	Model			0	10	20	30	40	50	60	70	80	90	100	110	120	130	140	150	160	Highly reinforced concrete	Concrete, granite, stone, brick	Metal/wood	Working direction
30mm series	HR3001C	3.9J	4.4 - 4.8	4-30 10-22 35-80																Diamond core 32 ~ 80 (dry type)	✓✓✓	✓✓✓	✓	↕
	SDS-plus			✓✓✓	✓✓✓	✓																		
30mm series	HR3011FC	3.9J	4.1 - 4.5	4-30 10-22 35-80																Diamond core 32 ~ 80 (dry type)	✓✓✓	✓✓✓	✓	↕
	SDS-plus			✓✓✓	✓✓✓	✓																		

		Impact energy according to EPTA05/2009: J	EPTA Weight (kg)	Impact energy scale (0-160 J)																MATERIAL FOR DRILLING				
Series	Model			0	10	20	30	40	50	60	70	80	90	100	110	120	130	140	150	160	Highly reinforced concrete	Concrete, granite, stone, brick	Metal/wood	Working direction
32mm series	HR3210C	5.0J	4.8 - 5.6	4-32 10-22 35-90																Diamond core 32 ~ 90 (dry type)	✓✓✓	✓✓✓	✓	↕
	SDS-plus			✓✓✓	✓✓✓	✓																		
32mm series	HR3200C	5.1J	4.8 - 5.6	4-32 10-22 35-90																Diamond core 32 ~ 90 (dry type)	✓✓✓	✓✓✓	✓	↕
	SDS-plus			✓✓✓	✓✓✓	✓																		

		Impact energy according to EPTA05/2009: J	EPTA Weight (kg)	Impact energy scale (0-160 J)																MATERIAL FOR DRILLING				
Series	Model			0	10	20	30	40	50	60	70	80	90	100	110	120	130	140	150	160	Highly reinforced concrete	Concrete, granite, stone, brick	Metal/wood	Working direction
35mm series	HR3530	6.2J	5.8	10-35 12-25 25-105																	✓✓✓	✓✓✓		↕
	17mm Hex			✓✓✓	✓✓✓																			

		Impact energy according to EPTA05/2009: J	EPTA Weight (kg)	Impact energy scale (0-160 J)																MATERIAL FOR DRILLING				
Series	Model			0	10	20	30	40	50	60	70	80	90	100	110	120	130	140	150	160	Highly reinforced concrete	Concrete, granite, stone, brick	Metal/wood	Working direction
40mm series	DHR400	8.0J	4.1 - 4.6	10-40 16-35 20-105																	✓✓✓	✓✓✓		↕
	SDS-max			✓✓✓	✓✓✓																			
40mm series	HR005G	8.0J	4.1 - 4.6	10-40 16-35 20-105																	✓✓✓	✓✓✓		↕
	SDS-max			✓✓✓	✓✓✓																			
40mm series	HR4013C	8.0J	6.2 - 6.9	10-40 16-35 20-105																	✓✓✓	✓✓✓		↕
	SDS-max			✓✓✓	✓✓✓																			
40mm series	HR4003C	8.3J	6.2 - 6.9	10-40 16-35 20-105																	✓✓✓	✓✓✓		↕
	SDS-max			✓✓✓	✓✓✓																			
40mm series	HR4001C	6.8J	6.3 - 6.7	10-40 16-35 20-105																	✓✓✓	✓✓✓		↕
	SDS-max			✓✓✓	✓✓✓																			
40mm series	HR4002	6.1J	6.6 - 6.8	10-40 16-32 20-105																	✓✓✓	✓✓✓		↕
	SDS-max			✓✓✓	✓✓✓																			
40mm series	HR4030C	9.2J	6.9	10-40 22-35 25-118																	✓✓✓	✓✓✓		↕
	17mm Hex			✓✓✓	✓✓✓																			

		Impact energy according to EPTA05/2009: J	EPTA Weight (kg)	Impact energy scale (0-160 J)																MATERIAL FOR DRILLING				
Series	Model			0	10	20	30	40	50	60	70	80	90	100	110	120	130	140	150	160	Highly reinforced concrete	Concrete, granite, stone, brick	Metal/wood	Working direction
45mm series	HR4511C	9.4J	8.9 - 9.1	10-45 22-40 20-125																	✓✓✓	✓✓✓		↕
	SDS-max			✓✓✓	✓✓✓																			
45mm series	HR4501C	10.1J	8.9 - 9.1	10-45 22-40 20-125																	✓✓✓	✓✓✓		↕
	SDS-max			✓✓✓	✓✓✓																			

		Impact energy according to EPTA05/2009: J	EPTA Weight (kg)	Impact energy scale (0-160 J)																MATERIAL FOR DRILLING				
Series	Model			0	10	20	30	40	50	60	70	80	90	100	110	120	130	140	150	160	Highly reinforced concrete	Concrete, granite, stone, brick	Metal/wood	Working direction
52mm series	HR006G	21.4J	12.9 - 14.3	19-52 25-45 20-160																	✓✓✓	✓✓✓		↕
	SDS-max			✓✓✓	✓✓✓																			
52mm series	HR5212C	20.0J	11 - 12	19-52 25-45 20-160																	✓✓✓	✓✓✓		↕
	SDS-max			✓✓✓	✓✓✓																			
52mm series	HR5202C	19.1J	11 - 12	19-52 25-45 20-160																	✓✓✓	✓✓✓		↕
	SDS-max			✓✓✓	✓✓✓																			
52mm series	HR5211C	18.9J	11.3 - 12.2	19-52 25-45 20-160																	✓✓✓	✓✓✓		↕
	SDS-max			✓✓✓	✓✓✓																			

CUTTING (New Material | Masonry | Metal)

4112HS 305mm (12")

204

Angle Cutter Mesin Pemotong 切割机



- **Smooth and comfortable cutting**
Pemotongan lancar dan selesa
平滑切割

Standard Equipment: **Socket Wrench**



Continuous Rating Input Input Kuasa Berterusan 额定输入功率	2,400W
Capacity Kapasiti 能力	Max cutting : 100mm (4")
Blade Diameter Diameter Bilah 锯片直径	305mm (12")
No Load Speed (RPM) Kelajuan Tanpa Beban 回转数	5,000
Overall Length Panjang Keseluruhan 总长度	648mm (25-1/2")
Net Weight Berat Bersih 净重	10.4kg (22.9lbs)
Power Supply Cord Kabel Wayar 电源线	2.5m (8.2ft)

4114S 355mm (14")

204

Angle Cutter Mesin Pemotong 切割机



- **Faster cutting for increased productivity**
Pemotongan cepat meningkatkan produktiviti
更快的切割提高生产力

Standard Equipment: **Wrench**



Continuous Rating Input Input Kuasa Berterusan 额定输入功率	2,400W
Capacity Kapasiti 能力	Max cutting : 125mm (5")
Wheel Diameter Diameter Bilah 锯片直径	355mm (14")
Hole Diameter Diameter Lubang 孔直径	25.4mm (1")
No Load Speed (RPM) Kelajuan Tanpa Beban 回转数	3,500
Dimensions (L x W x H) Dimensi 体积	673x240x329mm (26-1/2"x9-1/2"x13")
Net Weight Berat Bersih 净重	10.8kg (23.9lbs)
Power Supply Cord Kabel Wayar 电源线	2.5m (8.2ft)

SG1251J 125mm (5")

318

Wall Chaser Mesin Pemotong Dinding 石材开槽切割机



- **Clean, compact and comfortable**
Bersih, padat dan selesa
干净, 紧凑, 舒适

Standard Equipment: **Diamond Wheel x2, Hex Wrench,
Lock Nut Wrench**



Continuous Rating Input Input Kuasa Berterusan 额定输入功率	1,400W
Capacity Kapasiti 能力	Depth : 0-30mm (0 - 1-3/16") Width : 6-30mm (1/4 - 1-3/16")
Blade Diameter Diameter Bilah 锯片直径	125mm (5")
No Load Speed (RPM) Kelajuan Tanpa Beban 回转数	10,000
Dimensions (L x W x H) Dimensi 体积	350x151x178mm (13-3/4"x5-15/16"x7")
Net Weight Berat Bersih 净重	4.3kg (9.5lbs)
Power Supply Cord Kabel Wayar 电源线	5.0m (16.4ft)

4131 185mm (7-1/4")

303

Metal Cutter Mesin Memotong Logam 金属切割机



- **Powerful 1,100W motor cuts through various types of metal**
Motor berkuasa 1,100W sesuai untuk memotong pelbagai jenis logam
强力1,100W马达可切割多种金属

Standard Equipment: **Carbide-Tipped Saw Blade (B-04628),
Hex Wrench, Safety Goggles**



Continuous Rating Input Input Kuasa Berterusan 额定输入功率	1,100W
Blade Diameter Diameter Bilah 锯片直径	185mm (7-1/4")
Capacity Kapasiti 能力	Max cutting : 63mm (2-1/2")
No Load Speed (RPM) Kelajuan Tanpa Beban 回转数	3,500
Overall Length Panjang Keseluruhan 总长度	358mm (14-1/8")
Net Weight Berat Bersih 净重	4.8kg (11.3lbs)
Power Supply Cord Kabel Wayar 电源线	2.5m (8.2ft)

4100NH 110mm (4-3/8")

303

Cutter Mesin Pemotong 切割机



- **Powerful cutting in stone, masonry, tile & concrete**
Berkuasa untuk memotong batu, masonry, jubin & konkrit
有力的切割石材, 砖石, 瓷砖和混凝土

Standard Equipment: **Wrench, Socket Wrench**



Continuous Rating Input Input Kuasa Berterusan 额定输入功率	1,300W
Blade Diameter Diameter Bilah 锯片直径	110mm (4-3/8")
Max Cutting Capacity Kapasiti Pemotongan Maksimum 最大切割能力	90°: 34mm (1-3/8")
No Load Speed (RPM) Kelajuan Tanpa Beban 回转数	14,500
Dimensions (L x W x H) Dimensi 体积	234x210x165mm (9-1/4"x8-1/4"x6-1/2")
Net Weight Berat Bersih 净重	2.9kg (6.5lbs)
Power Supply Cord Kabel Wayar 电源线	2.5m (8.2ft)

Cordless
Tepat Kord 无线式

LED Flashlight
Lampu Suluh LED
LED照明灯

Vacuum Cleaner
Pembersih Vakuum
吸尘器

Drilling / Fastening
Capas / Pasang
钻孔 / 紧固

Impact Drilling / Demolition
Gertak / Rombok
打桩钻孔 / 拆除施工

Cutting
Pemotong
切割

Grinding / Sanding
Pengiraian / Pasir
打磨 / 砂磨

Sawing
Gergaji
锯切

Planing / Routing
Pegayaan / Tinggikan
刨削 / 雕刻

Others
Lain-lain
其他

Outdoor Power Equipment
Alatan Kertaji Luar
园林户外

Makita
MAKITA

CUTTING (New Material | Masonry | Metal)

LC1230 305mm (12")

203

Metal Cutting Saw
Mesin Memotong Logam
金属型材切割机

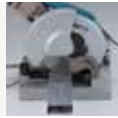

• For Cutting in Pipe, Angle Iron, Conduit and More
Untuk pemotongan paip, sesiku besi, konduit dan banyak lagi
用于切割管道, 角铁, 导管等

Standard Equipment: Carbide-Tipped Saw Blade, Socket Wrench, Safety Goggles



Continuous Rating Input Input Kuasa Berterusan 额定输入功率	1,750W
Blade Diameter Diameter Bilah 锯片直径	305mm (12")
Max Cutting Capacity Kapasiti Pemotongan Maksimum 最大切割能力	90°: 115mm (4-1/2") 90°: 75 x 150mm (2-15/16" x 5-7/8") 45°: 90mm (3-1/2") 45°: 85 x 85mm (3-5/16" x 3-5/16")
No Load Speed (RPM) Kelajuan Tanpa Beban 回转转速	1,300
Dimensions (L x W x H) Dimensi 体积	516x306x603mm (20-1/4"x12"x23-3/4")
Net Weight Berat Bersih 净重	19.3kg (42.5lbs)
Power Supply Cord Kabel Wayar 电源线	2.5m (8.2ft)

Why Makita Carbide-tipped Metal Cutting saw VS. Abrasive Cutting Saw



Carbide-Tipped Blades make Virtually Spark-Free Cuts

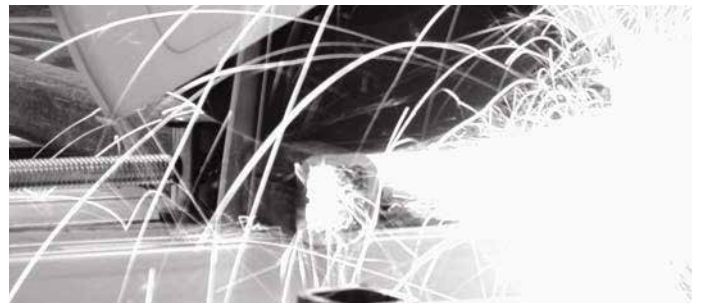

Abrasive Blades make Cuts with Sparks

Makita's Carbide-Tipped Metal Blades Cuts Cleaner

Tubing	Threaded Rod	UNISTRUT™	Angle Iron	Pipe
Makita Carbide-Tipped Blade	Makita Carbide-Tipped Blade	Makita Carbide-Tipped Blade	Makita Carbide-Tipped Blade	Makita Carbide-Tipped Blade
Abrasive Blade	Abrasive Blade	Abrasive Blade	Abrasive Blade	Abrasive Blade

Carbide-Tipped Metal Blades for Many Applications

Applications				Angle		Tubing		Channel		Round Pipe
Size (mm)	Tip thickness	Part No.	Nominal thickness	6mm	4mm	3mm	4.5mm	2.3mm	3.2mm	3.8mm
305 x 60T (Mild steel)	2.1mm	A-87242		○	○	○	△	×	◎	◎
305 x 60T (Mild steel)	2.5mm	A-81860		○	○	◎	○	×	◎	◎
305 x 60T (Mild steel) lessend noise	2.4mm	A-86723		◎	◎	◎	○	×	◎	◎
305 x 78T (Thin steel)	2.3mm	A-87127		△	△	△	×	○	△	△
305 x 76T (Thin steel)	1.95mm	A-87579		○	○	△	×	◎	△	◎

Cordless
Tape Measure
LED Flashlight
Vacuum Cleaner
Drilling / Fastening
Impact Drilling / Demolition
Cutting
Grinding / Sanding
Sawing
Planing / Routing
Others
Outdoor Power Equipment



CUTTING (New Material | Masonry | Metal)

Metal Cutting Process

Carbide-Tipped Metal Blade Cutting Tips

- Always wear safety glasses, gloves, protective equipment and follow instructions provided with power tool
- Do not apply excessive pressure on the handle when cutting as damage to the carbide-tips can be a result
- Too little or too much pressure on the handle may result in more sparks and premature blade wear
- Use block spacers when cutting square/rectangle tubing as well as channel and UNISTRUT™ for longer blade life
- When cutting long pieces of metal always use support blocks on both sides so the metal will be level with the saw base
- Do not touch blade or metal immediately after cut

Metal Cutting Process

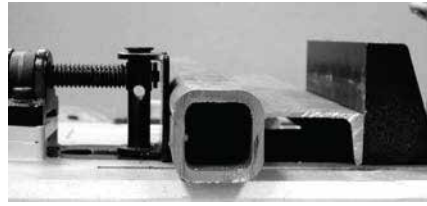

Square & Rectangle Tubing (use block spacer)

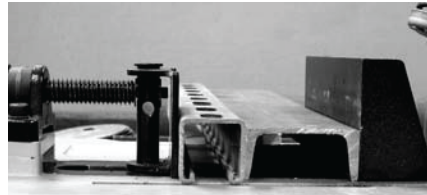

Channels & UNISTRUT™ (use block spacer)

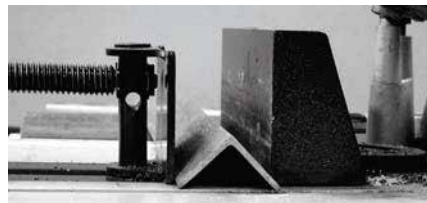

Angle

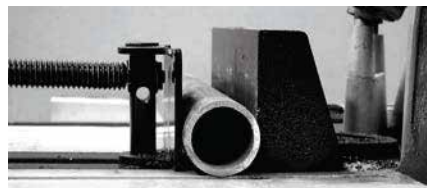

Round Pipe

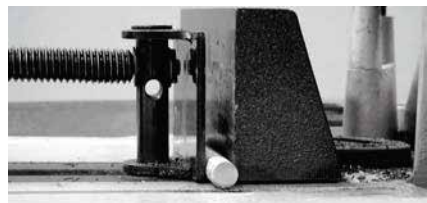

Threaded Rod

Carbide-Tipped Metal Blade Cutting Tips

- 1 Ensure metal is properly placed on saw base and firmly secured in the saw
- 2 Hold the saw handle firmly and wait until full speed is obtained
- 3 Lower the handle gently to bring the blade close to the metal
- 4 Gently ease the blade into the metal and add minimal pressure (reduce pressure if sparks appear)
- 5 After completed cut, turn off power tool and wait until blade has come to a complete stop then raise the handle back (if handle is raised back with blade still rotating then the blade may be caught)

Block Spacer Reference Chart

Applications	Square & Rectangle Tubing				Round Pipe		Square & Rectangle Tubing		Round Pipe			
	Up to 75 mm		Up to 100 mm		—		Up to 85 mm		—			
The height of material	A	B	A	B	A	B	A	B	A	B		
<p>Block Spacer</p> <p>Material</p> <p>A B</p> <p>(mm)</p>	90 Degree Cutting		25	125	25	75	25	90	25	65		
			50	100	50	50	50	65	50	35	50	40
			75	75	75	25	75	40	75	10	75	15
			100	50	100	0	100	15	85	0	90	0
			125	25	—	—	115	0	—	—	—	—
			*150	0	—	—	—	—	—	—	—	—
90 Degree Cutting		45 Degree Cutting		—		—		—		—		

*Hint: Block Spacer should be determined by subtracting the metal width from 150 mm.

Cordless
Target Area 10.8V

LED Flashlight
Lampu Saku LED
LED 3000K

Vacuum Cleaner
Penyedot Vakum
10.8V

Drilling / Fastening
Cairan / Pengikat
10.8V | 10.8V

Impact Drilling / Demolition
Cairan / Pemecah
10.8V | 10.8V

Cutting / Finishing
Pemotong
10.8V

Grinding / Sanding
Pengkilan / Pasir
10.8V | 10.8V

Sawing
Gergaji
10.8V

Planing / Routing
Pengkilan / Tumpang
10.8V | 10.8V

Others
Lain-lain
10.8V

Outdoor Power Equipment
Alat-alat Luar
10.8V | 10.8V

Makita
10.8V

CUTTING (New Material | Masonry)

Cordless
Tangan Keras 无绳式

LED Flashlight
Lampu Suluh LED
LED 照明灯

Vacuum Cleaner
Pembersih Vakum
吸尘器

Drilling / Fastening
Ganda / Pengikat
钻孔 / 紧固

Impact Drilling / Demolition
Ganda / Perusakan
起工钻孔 / 拆墙加工

Cutting
Pemotongan
切割

Grinding / Sanding
Penghalus / Pasir
打磨 / 砂磨

Sawing
Gergaji
锯切

Planing / Routing
Penghalus / Tumpang
刨削 / 雕刻

Others
Lain-lain
其他

Outdoor Power Equipment
Alat-alat Tenaga Luar
园机 / 户外



4100NH2Z 110mm (4-3/8")

303 W

Cutter
Mesin Pemotong
切割机



- **Bevel-cuts up to 45 degrees**
Potongan serong hingga 45°
45° 斜角切割

Standard Equipment: Wrench, Hex Wrench



Continuous Rating Input Input Kuasa Berterusan 额定输入功率	1,400W
Blade Diameter Diameter Bilah 锯片直径	Max 125mm (Max 5")
Max Cutting Capacity w/ 110mm (4-3/8") wheel Kapasiti Pemotongan Maksimum 最大切割能力	90°: 32.5mm (1-1/4") 45°: 21.5mm (7/8")
Max Cutting Capacity w/ 125mm (5") wheel Kapasiti Pemotongan Maksimum 最大切割能力	90°: 40.0mm (1-9/16") 45°: 27.0mm (1-1/16")
No Load Speed (RPM) Kelajuan Tanpa Beban 回转速数	12,200
Dimensions (L x W x H) Dimensi 体积	238x214x169mm (9-3/8"x8-3/8"x6-5/8")
Net Weight Berat Bersih 净重	3kg (6.6lbs)
Power Supply Cord Kabel Wayar 电源线	2.5m (8.2ft.)

4100NH3Z 110mm (4-3/8")

303 W

Cutter
Mesin Pemotong
切割机



- **Specialized for right angle cutting only**
Khusus untuk pemotongan sudut kanan sahaja
专为右斜角切割而设

Standard Equipment: Wrench, Hex Wrench



Continuous Rating Input Input Kuasa Berterusan 额定输入功率	1,300W
Blade Diameter Diameter Bilah 锯片直径	110mm (4-3/8")
Max Cutting Capacity Kapasiti Pemotongan Maksimum 最大切割能力	90°: 32mm (1-1/4")
No Load Speed (RPM) Kelajuan Tanpa Beban 回转速数	13,800
Dimensions (L x W x H) Dimensi 体积	227x209x166mm (8-15/16"x8-1/4"x6-1/2")
Net Weight Berat Bersih 净重	2.8kg (6.2lbs)
Power Supply Cord Kabel Wayar 电源线	2.0m (6.6ft.)

4100KB 125mm (5")

303 W

Dustless Cutter
Mesin Pemotong
切割机



- **Powerful 1,400W motor, cutting in stone, masonry, tile, concrete & more**
Motor berkuasa 1,400W, untuk memotong batu, masonri, jubin, konkrit dll
强力1,400W马达适合切割石材, 砖石, 瓷砖, 混凝土等

Standard Equipment: Diamond Wheel (D-38261),
Dust Bag (1267380), Wrench, Hex Wrench



Continuous Rating Input Input Kuasa Berterusan 额定输入功率	1,400W
Blade Diameter Diameter Bilah 锯片直径	125mm (5")
Max Cutting Capacity Kapasiti Pemotongan Maksimum 最大切割能力	40.0mm (1-9/16")
No Load Speed (RPM) Kelajuan Tanpa Beban 回转速数	12,200
Dimensions (L x W x H) Dimensi 体积	231x220x179mm (9-1/8"x8-5/8"x7")
Net Weight Berat Bersih 净重	3.0kg (6.6lbs.)
Power Supply Cord Kabel Wayar 电源线	2.5m (8.2ft.)

4107R 180mm (7-1/8")

153 W

Cutter
Mesin Pemotong
切割机



- **Ideal for stone materials (such as granite and marble), concrete and asphalt**
Sesuai untuk bahan batu seperti granit, marma, konkrit dan asfalt bahan
适用于石材如花岗岩, 大理石, 混凝土和沥青

Standard Equipment: Socket Wrench, Offset Wrench,
Water plug & tube



Continuous Rating Input Input Kuasa Berterusan 额定输入功率	1,400W
Capacity Kapasiti 能力	Max cutting : 60mm (2-3/8")
Blade Diameter Diameter Bilah 锯片直径	180mm (7-1/8")
No Load Speed (RPM) Kelajuan Tanpa Beban 回转速数	5,000
Overall Length Panjang Keseluruhan 总长度	370mm (14-9/16")
Net Weight Berat Bersih 净重	6.3kg (14.5lbs)
Power Supply Cord Kabel Wayar 电源线	5.0m (16.4ft)



CUTTING (Metal)



2107F

Portable Band Saw Pemotong Ringan 带锯机



- **Built-in fluorescent job light for clear view**
Lampu kerja fluoresen terbina dalam untuk penglihatan jelas
内置荧光工作灯，确保清晰视野

ACCESSORIES (Optional)



Standard Equipment:
Band Saw Blade, Hex Wrench



**Portable Band Saw
Stand & Cover**
Part No. 196326-7



303

Continuous Rating Input Input Kuasa Berterusan 额定输入功率	710W
Capacity Kapasiti 能力	Round: 120mm (4-3/4") Rectangular workpiece w/o stand: 120x120mm (4-3/4"x4-3/4")
Blade Speed Kelajuan Bilah 刀片速度	60m (200ft) - 105m (350ft)/ min
Dimensions (L x W x H) Dimensi 体积	508x188x256mm (20"x7-3/8"x10-1/8")
Net Weight Berat Bersih 净重	6.3kg (13.9lbs)
Power Supply Cord Kabel Wayar 电源线	2.5m (8.2ft)

LW1400 355mm (14")

Portable Cut-off Mesin Pemotong 型材切割机



- **Large spark guard prevents backward scattering of spark**
Pengawal pencucuh menghalang hamburan mundur dari percikan api
大的火花防护装置可防止火花向后散射

Standard Equipment: Abrasive Cut-Off Wheel



203

Continuous Rating Input Input Kuasa Berterusan 额定输入功率	2,200W
Wheel Diameter Diameter Bilah 锯片直径	355mm (14")
No Load Speed (RPM) Kelajuan Tanpa Beban 回转数	3,800
Capacity at 45° Kapasiti 能力	Round: 127mm (5") Rectangular: 115x103mm (4-1/2"x4-1/16") Square: 106x106 mm (4-3/16"x4-3/16") Triangular: 100x100x10mm (4"x4"x3/8")
Dimensions (L x W x H) Dimensi 体积	530x295x640mm (20-7/8"x11-5/8"x25-1/4")
Net Weight Berat Bersih 净重	18.7kg (41.2lbs)
Power Supply Cord Kabel Wayar 电源线	2.5m (8.2ft)

LW1401 355mm (14")

Portable Cut-off Mesin Pemotong 型材切割机



- **Powerful 2,200W motor**
Motor berkuasa 2,200W
强力2200W马达

Standard Equipment: Abrasive Cut-Off Wheel, Socket Wrench



203

Continuous Rating Input Input Kuasa Berterusan 额定输入功率	2,200W
Wheel Diameter Diameter Bilah 锯片直径	355mm (14")
No Load Speed (RPM) Kelajuan Tanpa Beban 回转数	3,800
Capacity at 45° Kapasiti 能力	Round: 127mm (5") Rectangular: 115x103mm (4-1/2"x4-1/16") Square: 106x106mm (4-3/16"x4-3/16") Triangular: 100x100x10mm (4"x4"x3/8")
Dimensions (L x W x H) Dimensi 体积	500x295x640mm (19-3/4"x11-5/8"x25-1/4")
Net Weight Berat Bersih 净重	18.3kg (40.3lbs)
Power Supply Cord Kabel Wayar 电源线	2.5m (8.2ft)

Cordless
Tepat Kord 无线式

LED Flashlight
Lampu Suluh LED
LED 闪光灯

Vacuum Cleaner
Pembersih Vakuum
吸尘器

Drilling / Fastening
Cetus / Pengikat
钻孔 / 紧固

Impact Drilling / Demolition
Cetus / Penceroboh
打桩钻孔 / 拆毁施工

Cutting
Pemotong
切割

Grinding / Sanding
Pengkilan / Palsan
研磨 / 砂磨

Sawing
Gergaji
锯切

Planing / Routing
Pencapaian / Tinggapan
刨削 / 雕刻

Others
Lain-lain
其他

Outdoor Power Equipment
Alatan Kuasa Luar
户外动力工具



CUTTING (Metal)

2416S 405mm (16")

153

Portable Cut-off Mesin Pemotong 型材切割机



- **Mitres 45° Left And Right**
Potongan miter 45° kiri dan kanan
左右45° 斜切割

Standard Equipment: **Abrasive Cut-Off Wheel, Socket Wrench**

Continuous Rating Input Input Kuasa Berterusan 额定输入功率	1,430W
Wheel Diameter Diameter Bilah 锯片直径	405mm (16")
Hole Diameter Diameter Lubang 孔直径	25.4mm (1")
No Load Speed (RPM) Kelajuan Tanpa Beban 回转数	2,300
Dimensions (L x W x H) Dimensi 体积	610x265x535mm (24"x10-3/8"x21")
Net Weight Berat Bersih 净重	19.2kg (42.3lbs)
Power Supply Cord Kabel Wayar 电源线	2.5m (8.2ft)

Model No. 型号	Cutting Angle Sudut Pemotongan 切割角度	Round Pipe Tiub Bulat 圆管	Rectangular Metal Logam Segi Empat Tepat 长方形金属	Square Metal Logam Segi Empat 方形金属	Angle Bar Besi Sudut 角铁
LC1230	90°	115mm	150 x 75mm	100mm	100mm
	45°	90mm	85 x 85mm	85mm	85mm
LW1400	90°	127mm	233 x 70mm	119mm	137mm
	45°	127mm	115 x 103mm	106mm	100mm
LW1401	90°	127mm	233 x 70mm	119mm	137mm
	45°	127mm	115 x 103mm	106mm	100mm
2416S	90°	115mm	230 x 80mm	120mm	150mm
	45°	115mm	110 x 110mm	110mm	110mm

JN1601 1.6mm (16Ga)

411

Nibbler Pemotong Elektrik 电冲剪



- **2,200 SPM for faster and smooth cutting**
2,200 SPM untuk pemotongan cepat dan lancar
2200 SPM更快更顺畅地切割

Standard Equipment: **Hex Wrench, Wrench, Punch, Die**



Continuous Rating Input Input Kuasa Berterusan 额定输入功率	550W
Capacity Kapasiti 能力	Steel up to 400 N/mm ² : 1.6mm Steel up to 600 N/mm ² : 1.2mm Steel up to 800 N/mm ² : 0.8mm Aluminum up to 200 N/mm ² : 2.5mm
Min. Cutting Radius Radius Pemotongan Minimum 最小切割半径	Outside edge : 50mm (2") Inside edge : 45mm (1-3/4")
Strokes Per Minute (SPM) Kelajuan Strok 冲程速度	2,200
Overall Length Panjang Keseluruhan 总长度	261mm (10-1/4")
Net Weight Berat Bersih 净重	1.6kg (3.6lbs)
Power Supply Cord Kabel Wayar 电源线	2.0m (6.6ft)

JN3201 3.2mm (10Ga)

303

Nibbler Pemotong Elektrik 电冲剪



- **Built-in thickness gauge for operator convenience**
Penyukat ketebalan terbina dalam memudahkan pengguna
内置测厚仪方便使用

Standard Equipment: **Punch, Die, Wrench 50, Hex Wrench, Washer**



Continuous Rating Input Input Kuasa Berterusan 额定输入功率	710W
Capacity Kapasiti 能力	Steel up to 400 N/mm ² : 3.2mm Steel up to 600 N/mm ² : 2.5mm Steel up to 800 N/mm ² : 1.0mm Aluminum up to 200 N/mm ² : 3.5mm
Min. Cutting Radius Radius Pemotongan Minimum 最小切割半径	Outside edge : 128mm (5-1/16") Inside edge : 120mm (4-3/4")
Strokes Per Minute (SPM) Kelajuan Strok 冲程速度	1,300
Dimensions (L x W x H) Dimensi 体积	225x90x254mm (8-7/8"x1-1/2"x10")
Net Weight Berat Bersih 净重	3.4kg (7.4lbs)
Power Supply Cord Kabel Wayar 电源线	2.5m (8.2ft)

Cordless
Tangkas Kordless

LED Flashlight
Lampu Suluh LED
LED 照明灯

Vacuum Cleaner
Pembersih Vakum
吸尘器

Drilling / Fastening
Ganda / Pengikat
钻孔 / 紧固

Impact Drilling / Demolition
Ganda / Pemecah
冲击钻孔 / 拆墙加工

Cutting
Pemotong
切割

Grinding / Sanding
Pengkilan / Polesan
研磨 / 打磨

Sawing
Ganda
锯切

Planing / Routing
Pengkilan / Tenggang
刨削 / 雕刻

Others
Lain-lain
其他

Outdoor Power Equipment
Alatan Krafis Luar
园具 / 户外



CUTTING (Metal)

JS1601 1.6mm (16Ga)

459

Straight Metal Shear Pemotong Elektrik 电剪刀



- **Fast Cutting Action in Steel and Aluminum**
Pemotongan Cepat untuk Keluli dan Aluminium
快速切割钢和铝



Standard Equipment: Hex Wrench, Thickness Gauge



Continuous Rating Input Input Kuasa Berterusan 额定输入功率	380W
Capacity Kapasiti 能力	Steel up to 400N/mm ² : 1.6mm Steel up to 600N/mm ² : 1.2mm Steel up to 800N/mm ² : 0.8mm Aluminum up to 200N/mm ² : 2.5mm 250mm (9-7/8")
Min. Cutting Radius Radius Pemotongan Minimum 最小切割半径	
Strokes Per Minute (SPM) Kelajuan Strok 冲程速度	4,500
Dimensions (L x W x H) Dimensi 体积	320x70x78mm (12-5/8"x2-3/4"x3-1/16")
Net Weight Berat Bersih 净重	1.4kg (3.2lbs)
Power Supply Cord Kabel Wayar 电源线	2.5m (8.2ft)

JS1300 1.3mm

419

Straight Shear Pemotong Elektrik 电剪刀



- **Shear head attachment rotates 360°**
Kepala pemotong boleh berputar 360°
剪切头附件可旋转360°



Standard Equipment: Hex Wrench



Continuous Rating Input Input Kuasa Berterusan 额定输入功率	570W
Capacity Kapasiti 能力	Steel up to 400N/mm ² : 1.3mm Steel up to 600N/mm ² : 1.0mm Steel up to 800N/mm ² : 0.5mm Aluminum up to 200N/mm ² : 2.5mm 0-2,500
Strokes Per Minute (SPM) Kelajuan Strok 冲程速度	
Overall Length Panjang Keseluruhan 总长度	302mm (11-7/8")
Net Weight Berat Bersih 净重	1.8kg (3.9lbs)
Power Supply Cord Kabel Wayar 电源线	2.5m (8.2ft)

JS1602 1.6mm (16Ga)

459

Metal Shear Pemotong Elektrik 电剪刀



- **Fast and efficient cutting**
Pemotongan cepat dan cekap
快速高效的切割



Standard Equipment: Hex Wrench, Shear Blade Set



Continuous Rating Input Input Kuasa Berterusan 额定输入功率	380W
Capacity Kapasiti 能力	Steel up to 400N/mm ² : 1.6mm Steel up to 600N/mm ² : 1.2mm Steel up to 800N/mm ² : 0.8mm Aluminum up to 200N/mm ² : 2.5mm 30mm (1-3/16")
Min. Cutting Radius Radius Pemotongan Minimum 最小切割半径	
Strokes Per Minute (SPM) Kelajuan Strok 冲程速度	4,000
Dimensions (L x W x H) Dimensi 体积	255x74x146mm (10"x2-15/16"x5-3/4")
Net Weight Berat Bersih 净重	1.6kg (3.4lbs)
Power Supply Cord Kabel Wayar 电源线	2.5m (8.2ft)

JS3201 3.2mm (10Ga)

303

Metal Shear Pemotong Elektrik 电剪刀



- **Powerful 710W Motor**
Motor berkuasa 710W
强力710W马达



Standard Equipment: Shear Blade Set, Hex Wrench,
Thickness Gauge



Continuous Rating Input Input Kuasa Berterusan 额定输入功率	710W
Capacity Kapasiti 能力	Steel up to 400N/mm ² : 3.2mm Steel up to 600N/mm ² : 2.5mm Steel up to 800N/mm ² : 1.5mm Aluminum up to 200N/mm ² : 4.0mm 50mm (2")
Min. Cutting Radius Radius Pemotongan Minimum 最小切割半径	
Strokes Per Minute (SPM) Kelajuan Strok 冲程速度	1,600
Dimensions (L x W x H) Dimensi 体积	213x90x239mm (8-3/8"x3-1/2"x9-3/8")
Net Weight Berat Bersih 净重	3.4kg (7.5lbs)
Power Supply Cord Kabel Wayar 电源线	2.5m (8.2ft)

CA5000X 118mm (4-5/8")

303

Aluminum Groove Cutter Mesin Memotong Aluminium 铝板开槽切割机



- **Cutter blade for 135 degrees V shaped groove as an option**
Bilah pemotong alur 135° berbentuk V pemilihan
可选135° V形槽的锯片



Standard Equipment: Cutter Blade, Plate, Hex Wrench



Continuous Rating Input Input Kuasa Berterusan 额定输入功率	1,300W
Blade Bilah 锯片	Type: Cutter blade/ TCT saw blade
Max Cutting Capacity w/ Cutter blade Kapasiti Pemotongan Maksimum 最大切割能力	w/ Guide rail: 11mm (7/16")
Max Cutting Capacity w/ TCT Saw blade Kapasiti Pemotongan Maksimum 最大切割能力	w/ Guide rail: 36mm (1-7/16") w/o Guide rail: 41mm (1-5/8") 2,200-6,400
No Load Speed (RPM) Kelajuan Tanpa Beban 回转数	
Dimensions (L x W x H) Dimensi 体积	346x250x250mm (13-5/8"x9-7/8"x9-7/8")
Net Weight Berat Bersih 净重	4.7kg (10.4lbs)
Power Supply Cord Kabel Wayar 电源线	2.5m (8.2ft)

Cordless
Tepat Kord 无线式

LED Flashlight
Lampu Suluh LED
LED照明灯

Vacuum Cleaner
Pembersih Vakum
吸尘器

Drilling / Fastening
Cairul / Pengikat
钻孔 / 紧固

Impact Drilling / Demolition
Cairul / Penceroboh
打桩钻孔 / 拆除施工

Cutting
Pemotong
切割

Grinding / Sanding
Hengkil / Palsah
打磨 / 砂磨

Sawing
Gajul
锯切

Planing / Routing
Peyulian / Tinggung
刨削 / 雕刻

Others
Lain-lain
其他

Outdoor Power Equipment
Alatan Kuasa Luar
园林户外

Makita
MAKITA

GRINDING | SANDING



Cordless
Tanpa Hood 无线式

LED Flashlight
Lampu Suhu LED
LED 照明灯

Vacuum Cleaner
Pembersih Vakum
吸尘器

Drilling | Fastening
Ganda | Pengikat
钻孔 | 紧固

Impact Drilling | Demolition
Ganda | Penembak
起孔钻孔 | 拆除加工

Cutting
Pemotong
切割

Grinding | Sanding
Pengisar | Pasir
磨削 | 打磨

Sawing
Gergaji
锯切

Planing | Routing
Pengaliran | Tanggapan
刨削 | 雕刻

Others
Lain-lain
其他

Outdoor Power Equipment
Alat-alat Luar
园机-户外

Makita
Makita

9553HNG 100mm (4")

325 W

Angle Grinder Pengisar Sudut 角向磨光机



Slide Switch Suis Gelangsar 滑动开关

- **Spiral bevel gears for smoother rotations**
Gear serong lingkaran untuk putaran yang licin
螺旋锥齿轮更平滑的旋转



Sementara stok masih ada
WHILE STOCK LAST
可保供应

Standard Equipment: Depressed Center Wheel (A-80852), Side Grip, Wheel Cover, Lock Nut Wrench



Continuous Rating Input Input Kuasa Berterusan 额定输入功率	710W
Wheel Diameter Diameter Roda 轮片直径	100mm (4")
No Load Speed (RPM) Kelajuan Tanpa Beban 回转数	11,000
Dimensions (L x W x H) Dimensi 体积	258x118x97mm (10-1/8"x4-5/8"x3-13/16")
Net Weight Berat Bersih 净重	1.5 - 1.8kg (3.2 - 4.1lbs)
Power Supply Cord Kabel Wayar 电源线	2.5m (8.2ft.)

9553HBG 100mm (4")

325 W

Angle Grinder Pengisar Sudut 角向磨光机



Toggle Switch Suis Togol 后置式开关

- **Compact design and lightweight**
Reka bentuk padat dan ringan
设计紧凑，轻量



Standard Equipment: Depressed Center Wheel (A-80852), Wheel Cover, Lock Nut Wrench



Continuous Rating Input Input Kuasa Berterusan 额定输入功率	710W
Wheel Diameter Diameter Roda 轮片直径	100mm (4")
No Load Speed (RPM) Kelajuan Tanpa Beban 回转数	11,000
Dimensions (L x W x H) Dimensi 体积	258x118x97mm (10-1/8"x4-5/8"x3-13/16")
Net Weight Berat Bersih 净重	1.5 - 1.9kg (3.3 - 4.1lbs)
Power Supply Cord Kabel Wayar 电源线	2.5m (8.2ft.)

GA4030R 100mm (4")

459 W

Angle Grinder Pengisar Sudut 角向磨光机



Slide Switch Suis Gelangsar 滑动开关

- **Machined bevel gears provide up to 2x longer service life**
Gear bevel machined mempanjangkan hayat penggunaan 2x lebih lama
加工锥齿轮延长了长达 2x 的使用寿命



Standard Equipment: Depressed Center Wheel (A-80852), Side Grip, Wheel Cover, Lock Nut Wrench



Continuous Rating Input Input Kuasa Berterusan 额定输入功率	720W
Wheel Diameter Diameter Roda 轮片直径	100mm (4")
No Load Speed (RPM) Kelajuan Tanpa Beban 回转数	11,000
Dimensions (L x W x H) Dimensi 体积	266x118x102mm (10-1/2"x4-5/8"x4")
Net Weight Berat Bersih 净重	1.72 - 2.01kg (3.79 - 4.43lbs)
Power Supply Cord Kabel Wayar 电源线	2.5m (8.2ft)

GA4030 100mm (4")

459 W

Angle Grinder Pengisar Sudut 角向磨光机



Slide Switch Suis Gelangsar 滑动开关

- **All ball bearing construction for durability and longer tool life**
Struktur galas bola untuk mempanjangkan hayat alat
滚珠轴承结构延长工具寿命



Standard Equipment: Depressed Center Wheel (A-80852), Side Grip, Wheel Cover, Lock Nut Wrench



Continuous Rating Input Input Kuasa Berterusan 额定输入功率	720W
Wheel Diameter Diameter Roda 轮片直径	100mm (4")
No Load Speed (RPM) Kelajuan Tanpa Beban 回转数	11,000
Dimensions (L x W x H) Dimensi 体积	266x117x95mm (10-1/2"x4-5/8"x3-3/4")
Net Weight Berat Bersih 净重	1.73 - 2.02kg (3.81 - 4.45lbs)
Power Supply Cord Kabel Wayar 电源线	2.5m (8.2ft)

GRINDING | SANDING

GA4031 100mm (4")

459 WATT

Angle Grinder Pengisar Sudut 角向磨光机



Toggle Switch

Suis Togol 后置式开关

- **Toggle switch for easy operation**
Suis togol untuk operasi lebih mudah
后置式开关方便操作



Standard Equipment: Depressed Center Wheel (A-80852),
Wheel Cover, Lock Nut Wrench



Continuous Rating Input Input Kuasa Berterusan 额定输入功率	720W
Wheel Diameter Diameter Roda 轮片直径	100mm (4")
No Load Speed (RPM) Kelajuan Tanpa Beban 回转数	11,000
Dimensions (L x W x H) Dimensi 体积	259x118x104mm (10-1/4"x4-5/8"x4-1/8")
Net Weight Berat Bersih 净重	1.71 - 2.00kg (3.77 - 4.41lbs)
Power Supply Cord Kabel Wayar 电源线	2.5m (8.2ft)

GA4034 100mm (4")

459 WATT

Angle Grinder Pengisar Sudut 角向磨光机



Paddle Switch

Suis Pemacu 扳机开关

- **Machined bevel gears provide up to 2x longer service life**
Gear bevel machined memajukan hayat penggunaan 2x lebih lama
加工锥齿轮延长了长达 2x 的使用寿命



Standard Equipment: Depressed Center Wheel (A-80852),
Side Grip, Wheel Cover, Lock Nut Wrench



Continuous Rating Input Input Kuasa Berterusan 额定输入功率	720W
Wheel Diameter Diameter Roda 轮片直径	100mm (4")
No Load Speed (RPM) Kelajuan Tanpa Beban 回转数	11,000
Dimensions (L x W x H) Dimensi 体积	265x118x95mm (10-3/8"x4-5/8"x3-3/4")
Net Weight Berat Bersih 净重	1.77 - 2.06kg (3.90 - 4.54lbs)
Power Supply Cord Kabel Wayar 电源线	2.5m (8.2ft)

9556HNG / HN / NB 100mm (4")

325 WATT

Angle Grinder Pengisar Sudut 角向磨光机



Slide Switch

Suis Gelangsar 滑动开关

- **Powerful 840W motor**
Motor berkuasa 840W
强力840W马达



Standard Equipment: Depressed Center Wheel (A-80852),
Side Grip, Wheel Cover, Lock Nut Wrench



Continuous Rating Input Input Kuasa Berterusan 额定输入功率	840W
Wheel Diameter Diameter Roda 轮片直径	100mm (4")
No Load Speed (RPM) Kelajuan Tanpa Beban 回转数	11,000
Dimensions (L x W x H) Dimensi 体积	271x118x97mm (10-5/8"x4-5/8"x3-13/16")
Net Weight Berat Bersih 净重	1.6 - 2.0kg (3.6 - 4.4lbs)
Power Supply Cord Kabel Wayar 电源线	2.5m (8.2ft)

9556HPG 100mm (4")

325 WATT

Angle Grinder Pengisar Sudut 角向磨光机



Paddle Switch

Suis Pemacu 扳机开关

- **Powerful 840W motor**
Motor berkuasa 840W
强力840W马达



Standard Equipment: Depressed Center Wheel (A-80852),
Side Grip, Wheel Cover, Lock Nut Wrench



Continuous Rating Input Input Kuasa Berterusan 额定输入功率	840W
Wheel Diameter Diameter Roda 轮片直径	100mm (4")
No Load Speed (RPM) Kelajuan Tanpa Beban 回转数	11,000
Dimensions (L x W x H) Dimensi 体积	273x118x97mm (10-3/4"x4-5/8"x3-13/16")
Net Weight Berat Bersih 净重	1.6 - 2.0kg (3.6 - 4.4lbs)
Power Supply Cord Kabel Wayar 电源线	2.5m (8.2ft)

GA4040 100mm (4")

325 WATT

Angle Grinder Pengisar Sudut 角向磨光机



Slide Switch

Suis Gelangsar 滑动开关

- **Spiral bevel gears for smoother rotations and a more efficient transfer of energy**
gear serong lingkaran untuk pemindahan tenaga yang lebih cekap
螺旋锥齿轮高效输送能源



Standard Equipment: Depressed Center Wheel (A-80852),
Side Grip, Wheel Cover, Lock Nut Wrench



Continuous Rating Input Input Kuasa Berterusan 额定输入功率	1,100W
Wheel Diameter Diameter Roda 轮片直径	100mm (4")
No Load Speed (RPM) Kelajuan Tanpa Beban 回转数	11,000
Dimensions (L x W x H) Dimensi 体积	303x117x111mm (11-7/8"x4-5/8"x4-3/8")
Net Weight Berat Bersih 净重	2.2 - 2.5kg (4.9 - 5.6lbs)
Power Supply Cord Kabel Wayar 电源线	2.5m (8.2ft)

Cordless
Tangkas Akut 无绳式LED Flashlight
Lampu Suluh LED
LED照明灯Vacuum Cleaner
Pembersih Vakuum
吸尘器Drilling / Fastening
Cairul / Pengikat
钻孔 / 紧固Impact Drilling / Demolition
Cairul / Penebuk
石工钻孔 / 拆毁动工Cutting
Pembaharu
切割Grinding / Sanding
Pangkas / Poles
研磨 / 打磨Sawing
Gergaji
锯切Planing / Routing
Peyjukan / Tunggam
刨削 / 雕刻Others
Lain-lain
其他Outdoor Power Equipment
Alatan Kuat Luar
园林户外Thakita
TENT

GRINDING | SANDING

Cordless
Turret Head 炮台式

LED Flashlight
Lampu Suhu LED
LED 照明灯

Vacuum Cleaner
Pembersih Vakuum
吸尘器

Drilling | Fastening
Ganda | Pemencok
钻孔 | 紧固

Impact Drilling | Demolition
Ganda | Pemencok
冲击钻孔 | 拆除加工

Cutting
Pemotong
切割

Grinding | Sanding
Pengisar | Poles
磨削 | 打磨

Sawing
Gergaji
锯切

Planing | Routing
Pengaliran | Tanggapan
刨削 | 雕刻

Others
Lain-lain
其他

Outdoor Power Equipment
Alat-alat Listrik
园林-户外

Makita
19157

GA4051R 100mm (4")

260

Angle Grinder
Pengisar Sudut
角向磨光机



Paddle Switch
Suis Pemacu 扳机开关

- Powerful 1,300W motor delivers 11,000RPM for high output power



Standard Equipment: Side Grip, Wheel Cover, Lock Nut Wrench



Continuous Rating Input Input Kuasa Berterusan 额定输入功率	1,300W
Wheel Diameter Diameter Roda 轮片直径	100mm (4")
Wheel Hole Diameter Diameter Lubang Roda 轮片孔直径	16mm (5/8")
Max Wheel Thickness Ketebalan Roda Maksimum 最大轮片厚度	6.4mm (1/4")
No Load Speed (RPM) Kelajuan Tanpa Beban 回转数	11,000
Dimensions (L x W x H) Dimensi 体积	325x117x100mm (12-3/4"x4-5/8"x4-5/16")
Net Weight Berat Bersih 净重	2.3 - 2.5kg (5.1 - 5.5lbs.)
Power Supply Cord Kabel Wayar 电源线	2.5m (8.2ft)

GA4041C 100mm (4")

318

Angle Grinder
Pengisar Sudut
角向磨光机



Slide Switch
Suis Gelangsar 滑动开关

- Super Joint System II developed for effective vibration absorption
SJS generasi kedua berkesan untuk menyerap getaran
第二代 SJS 有效抑止震动



Standard Equipment: Depressed Center Wheel (A-80852), Side Grip, Wheel Cover, Lock Nut Wrench



Continuous Rating Input Input Kuasa Berterusan 额定输入功率	1,400W
Wheel Diameter Diameter Roda 轮片直径	100mm (4")
No Load Speed (RPM) Kelajuan Tanpa Beban 回转数	2,800-11,000
Dimensions (L x W x H) Dimensi 体积	325x117x117mm (12-3/4"x4-5/8"x4-5/8")
Net Weight Berat Bersih 净重	2.5 - 2.8kg (5.6 - 6.2lbs)
Power Supply Cord Kabel Wayar 电源线	2.5m (8.2ft)

GA4040C 100mm (4")

318

Angle Grinder
Pengisar Sudut
角向磨光机



Slide Switch
Suis Gelangsar 滑动开关

- Super Joint System II developed for effective vibration absorption
SJS generasi kedua berkesan untuk menyerap getaran
第二代 SJS 有效抑止震动



Standard Equipment: Depressed Center Wheel (A-80852), Side Grip, Wheel Cover, Lock Nut Wrench



Continuous Rating Input Input Kuasa Berterusan 额定输入功率	1,400W
Wheel Diameter Diameter Roda 轮片直径	100mm (4")
No Load Speed (RPM) Kelajuan Tanpa Beban 回转数	2,800-11,000
Dimensions (L x W x H) Dimensi 体积	303x117x111mm (11-7/8"x4-5/8"x4-3/8")
Net Weight Berat Bersih 净重	2.3 - 2.6kg (5.1 - 5.7lbs)
Power Supply Cord Kabel Wayar 电源线	2.5m (8.2ft)



GA4530 115mm (4-1/2")

459

Angle Grinder
Pengisar Sudut
角向磨光机



Slide Switch
Suis Gelangsar 滑动开关

- Small diameter barrel grip for added comfort
Genggaman barel diameter kecil meningkatkan keselesaan
小直径桶形手柄，增加手握舒适度



Standard Equipment: Depressed Center Wheel (A-80640), Side Grip, Wheel Cover, Lock Nut Wrench



Continuous Rating Input Input Kuasa Berterusan 额定输入功率	720W
Wheel Diameter Diameter Roda 轮片直径	115mm (4-1/2")
No Load Speed (RPM) Kelajuan Tanpa Beban 回转数	11,000
Dimensions (L x W x H) Dimensi 体积	266x128x103mm (10-1/2"x5"x4-1/16")
Net Weight Berat Bersih 净重	1.89 - 2.23kg (4.17 - 4.91lbs)
Power Supply Cord Kabel Wayar 电源线	2.5m (8.2ft)

GRINDING | SANDING

GA4530R 115mm (4-1/2")

459 WATT

Angle Grinder Pengisar Sudut 角向磨光机



Slide Switch

Suis Gelangsar 滑动开关

- **Anti-restart function prevents accidental start-up**
Fungsi anti-restart menghalang penghidupan yang tidak disengajakan
防重启功能可防止意外启动

Standard Equipment: Depressed Center Wheel (A-80640), Side Grip, Wheel Cover, Lock Nut Wrench



Sementara stok masih ada
WHILE STOCK LAST
有限库存 欲购从速

Continuous Rating Input Input Kuasa Berterusan 额定输入功率	720W
Wheel Diameter Diameter Roda 轮片直径	115mm (4-1/2")
No Load Speed (RPM) Kelajuan Tanpa Beban 回转数	11,000
Dimensions (L x W x H) Dimensi 体积	266x130x108mm (10-1/2"x5-1/2"x4-1/4")
Net Weight Berat Bersih 净重	1.88 - 2.22kg (4.14 - 4.89lbs)
Power Supply Cord Kabel Wayar 电源线	2.5m (8.2ft)

9557HNG / NBG 115mm (4-1/2")

325 WATT

Angle Grinder Pengisar Sudut 角向磨光机



Slide Switch

Suis Gelangsar 滑动开关

- **Powerful 840W motor**
Motor berkuasa 840W
强力840W马达

Standard Equipment: Depressed Center Wheel, Side Grip, Wheel Cover, Lock Nut Wrench



Continuous Rating Input Input Kuasa Berterusan 额定输入功率	840W
Wheel Diameter Diameter Roda 轮片直径	115mm (4-1/2")
No Load Speed (RPM) Kelajuan Tanpa Beban 回转数	11,000
Dimensions (L x W x H) Dimensi 体积	271x129x106mm (10-5/8"x5-1/8"x4-3/16")
Net Weight Berat Bersih 净重	1.7 - 2.2kg (3.8 - 4.8lbs)
Power Supply Cord Kabel Wayar 电源线	2.5m (8.2ft)

9557HPG 115mm (4-1/2")

325 WATT

Angle Grinder Pengisar Sudut 角向磨光机



Paddle Switch

Suis Pemacu 扳机开关

- **Large Flush-Mount Paddle Switch for Comfortable Operation**
Suis Flush-mount mudah digunakan
大型平装式扳机开关易于操作

Standard Equipment: Depressed Center Wheel, Side Grip, Wheel Cover, Lock Nut Wrench



Continuous Rating Input Input Kuasa Berterusan 额定输入功率	840W
Wheel Diameter Diameter Roda 轮片直径	115mm (4-1/2")
No Load Speed (RPM) Kelajuan Tanpa Beban 回转数	11,000
Dimensions (L x W x H) Dimensi 体积	273x129x106mm (10-3/4"x5-1/8"x4-3/16")
Net Weight Berat Bersih 净重	1.8 - 2.2kg (3.9 - 4.8lbs)
Power Supply Cord Kabel Wayar 电源线	2.5m (8.2ft)

GA4540R 115mm (4-1/2")

325 WATT

Angle Grinder Pengisar Sudut 角向磨光机



Slide Switch

Suis Gelangsar 滑动开关

- **Super Joint System II developed for effective vibration absorption**
SJS generasi kedua berkesan untuk menyerap getaran
第二代 SJS 有效抑止震动

Standard Equipment: Depressed Center Wheel (A-80640), Side Grip, Wheel Cover, Lock Nut Wrench



Continuous Rating Input Input Kuasa Berterusan 额定输入功率	1,100W
Wheel Diameter Diameter Roda 轮片直径	115mm (4-1/2")
No Load Speed (RPM) Kelajuan Tanpa Beban 回转数	11,000
Dimensions (L x W x H) Dimensi 体积	303x130x116mm (11-7/8"x5-1/8"x4-9/16")
Net Weight Berat Bersih 净重	2.4 - 2.8kg (5.4 - 6.1lbs)
Power Supply Cord Kabel Wayar 电源线	2.5m (8.2ft)

GA4540 115mm (4-1/2")

325 WATT

Angle Grinder Pengisar Sudut 角向磨光机



Slide Switch

Suis Gelangsar 滑动开关

- **Super Joint System II developed for effective vibration absorption**
SJS generasi kedua berkesan untuk menyerap getaran
第二代 SJS 有效抑止震动

Standard Equipment: Depressed Center Wheel (A-80640), Side Grip, Wheel Cover, Lock Nut Wrench



Continuous Rating Input Input Kuasa Berterusan 额定输入功率	1,100W
Wheel Diameter Diameter Roda 轮片直径	115mm (4-1/2")
No Load Speed (RPM) Kelajuan Tanpa Beban 回转数	11,000
Dimensions (L x W x H) Dimensi 体积	303x130x116mm (11-7/8"x5-1/8"x4-9/16")
Net Weight Berat Bersih 净重	2.3 - 2.7kg (5.2 - 5.9lbs)
Power Supply Cord Kabel Wayar 电源线	2.5m (8.2ft)

Cordless
Tempa Kord 充电式

LED Flashlight
Lampu Suis LED
LED手电筒

Vacuum Cleaner
Pembersih Vakuum
吸尘器

Drilling / Fastening
Cairul / Pasang
钻孔 / 紧固

Impact Drilling / Demolition
Cairul / Hancurkan
冲击钻孔 / 拆除施工

Cutting
Pemotong
切割

Grinding / Sanding
Pangkas / Poles
打磨 / 研磨

Sawing
Gergaji
锯切

Planing / Routing
Perataan / Tunggam
刨削 / 雕刻

Others
Lain-lain
其他

Outdoor Power Equipment
Alatan Kuat Luar
园林户外

Thakita
TENTU

GRINDING | SANDING

GA4541C 115mm (4-1/2")

318

Angle Grinder Pengisar Sudut 角向磨光机



Slide Switch

Suis Geligangsar 滑动开关

- **Super Joint System II developed for effective vibration absorption**
SJS generasi kedua berkesan untuk menyerap getaran
第二代 SJS 有效抑止震动

Standard Equipment: Depressed Center Wheel (D-18459), Side Grip, Wheel Cover, Lock Nut Wrench



Continuous Rating Input Input Kuasa Berterusan 额定输入功率	1,400W
Wheel Diameter Diameter Roda 轮片直径	115mm (4-1/2")
No Load Speed (RPM) Kelajuan Tanpa Beban 回转速数	2,800-11,000
Dimensions (L x W x H) Dimensi 体积	325x130x121mm (12-3/4"x5-1/8"x4-3/4")
Net Weight Berat Bersih 净重	2.7 - 3.0kg (5.9 - 6.7lbs)
Power Supply Cord Kabel Wayar 电源线	2.5m (8.2ft)



GA5030 125mm (5")

459

Angle Grinder Pengisar Sudut 角向磨光机



Slide Switch

Suis Geligangsar 滑动开关

- **Machined bevel gears provide up to 2x longer service life**
Gear bevel machined memanjangkan hayat penggunaan 2x lebih lama
加工锥齿轮延长了长达 2x 的使用寿命

Standard Equipment: Depressed Center Wheel (A-80656), Side Grip, Wheel Cover, Lock Nut Wrench



Continuous Rating Input Input Kuasa Berterusan 额定输入功率	720W
Wheel Diameter Diameter Roda 轮片直径	125mm (5")
No Load Speed (RPM) Kelajuan Tanpa Beban 回转速数	11,000
Dimensions (L x W x H) Dimensi 体积	266x138x103mm (10-1/2"x5-7/16"x4-1/16")
Net Weight Berat Bersih 净重	1.92 - 3.07kg (4.23 - 6.77lbs)
Power Supply Cord Kabel Wayar 电源线	2.5m (8.2ft)

GA5030R 125mm (5")

459

Angle Grinder Pengisar Sudut 角向磨光机



Slide Switch

Suis Geligangsar 滑动开关

- **Anti-restart function prevents accidental start-up**
Fungsi anti-restart menghalang penghidupan yang tidak disengajakan
防重启功能可防止意外启动

Standard Equipment: Depressed Center Wheel (A-80656), Side Grip, Wheel Cover, Lock Nut Wrench



Continuous Rating Input Input Kuasa Berterusan 额定输入功率	720W
Wheel Diameter Diameter Roda 轮片直径	125mm (5")
No Load Speed (RPM) Kelajuan Tanpa Beban 回转速数	11,000
Dimensions (L x W x H) Dimensi 体积	266x140x108mm (10-1/2"x5-1/2"x4-1/4")
Net Weight Berat Bersih 净重	1.91 - 3.06kg (4.21 - 6.75lbs)
Power Supply Cord Kabel Wayar 电源线	2.5m (8.2ft)

GA5034 125mm (5")

459

Angle Grinder Pengisar Sudut 角向磨光机



Paddle Switch

Suis Pemacu 扳机开关

- **Small Diameter Barrel Grip**
Genggam Barrel Diameter Kecil
小直径握握

Standard Equipment: Depressed Center Wheel (A-80656), Side Grip, Wheel Cover, Lock Nut Wrench



Continuous Rating Input Input Kuasa Berterusan 额定输入功率	720W
Wheel Diameter Diameter Roda 轮片直径	125mm (5")
No Load Speed (RPM) Kelajuan Tanpa Beban 回转速数	11,000
Dimensions (L x W x H) Dimensi 体积	265x139x103mm (10-3/8"x5-1/2"x4-1/16")
Net Weight Berat Bersih 净重	2.00 - 3.15kg (4.41 - 6.94lbs)
Power Supply Cord Kabel Wayar 电源线	2.5m (8.2ft)

GRINDING | SANDING

9558HNG / NBG 125mm (5")

325 W

Angle Grinder
Pengisar Sudut
角向磨光机



Slide Switch

Suis Gelangsar 滑动开关

- **Slide switch with lock-on for continuous use**
Suis gelangsar dengan fungsi mengunci untuk kegunaan berterusan
备有锁定功能的滑动按钮可连续无间断的使用



Standard Equipment: Depressed Center Wheel, Side Grip, Wheel Cover, Lock Nut Wrench



Continuous Rating Input Input Kuasa Berterusan 额定输入功率	840W
Wheel Diameter Diameter Roda 轮片直径	125mm (5")
No Load Speed (RPM) Kelajuan Tanpa Beban 回转数	11,000
Dimensions (L x W x H) Dimensi 体积	271x139x106mm (10-5/8"x5-1/2"x4-3/16")
Net Weight Berat Bersih 净重	1.7 - 3.2kg (3.8 - 6.6lbs)
Power Supply Cord Kabel Wayar 电源线	2.5m (8.2ft.)

9558HPG 125mm (5")

325 W

Angle Grinder
Pengisar Sudut
角向磨光机



Paddle Switch

Suis Pemacu 扳机开关

- **Large Flush-Mount Paddle Switch for Comfortable Operation**
Suis Flush-mount mudah digunakan
大型平装式扳机开关易于操作



Standard Equipment: Depressed Center Wheel, Side Grip, Wheel Cover, Lock Nut Wrench



Continuous Rating Input Input Kuasa Berterusan 额定输入功率	840W
Wheel Diameter Diameter Roda 轮片直径	125mm (5")
No Load Speed (RPM) Kelajuan Tanpa Beban 回转数	11,000
Dimensions (L x W x H) Dimensi 体积	273x139x106mm (10-3/4"x5-1/2"x4-3/16")
Net Weight Berat Bersih 净重	1.8 - 3.0kg (3.9 - 6.7lbs)
Power Supply Cord Kabel Wayar 电源线	2.5m (8.2ft)

GA5020 125mm (5")

303 W

Angle Grinder
Pengisar Sudut
角向磨光机



Trigger Switch

Suis Pemacu 扳机开关

- **SJS Mechanical Clutch System Helps Prevent Motor and Gear Damage**
Sistem SJS mencegah kerosakan pada motor dan gear
SJS 系统有助于防止马达和齿轮损坏



Standard Equipment: Depressed Center Wheel (A-80656), Side Grip, Wheel Cover, Lock Nut Wrench



Continuous Rating Input Input Kuasa Berterusan 额定输入功率	1,050W
Wheel Diameter Diameter Roda 轮片直径	125mm (5")
No Load Speed (RPM) Kelajuan Tanpa Beban 回转数	12,000
Dimensions (L x W x H) Dimensi 体积	356x139x120mm (14"x5-1/2"x4-3/4")
Net Weight Berat Bersih 净重	2.7 - 3.9kg (6.0 - 8.6lbs)
Power Supply Cord Kabel Wayar 电源线	2.5m (8.2ft)

GA5010 125mm (5")

303 W

Angle Grinder
Pengisar Sudut
角向磨光机



Trigger Switch

Suis Pemacu 扳机开关

- **Powerful 1,050W motor**
Motor berkuasa 1,050W
强力1.050W马达



Standard Equipment: Depressed Center Wheel (A-80656), Side Grip, Wheel Cover, Lock Nut Wrench



Continuous Rating Input Input Kuasa Berterusan 额定输入功率	1,050W
Wheel Diameter Diameter Roda 轮片直径	125mm (5")
No Load Speed (RPM) Kelajuan Tanpa Beban 回转数	12,000
Dimensions (L x W x H) Dimensi 体积	356x139x112mm (14"x5-1/2"x4-3/8")
Net Weight Berat Bersih 净重	2.6 - 3.8kg (5.8 - 8.4lbs)
Power Supply Cord Kabel Wayar 电源线	2.5m (8.2ft)

GA5040 125mm (5")

325 W

Angle Grinder
Pengisar Sudut
角向磨光机



Slide Switch

Suis Gelangsar 滑动开关

- **Connectable to Makita vacuum cleaner with optional dust collecting wheel guard**
Boleh bersambung dengan pembersih vakum Makita dengan alat pilihan pengumpul debu
可选附件轮状集尘罩以连接 Makita 吸尘器



Standard Equipment: Depressed Center Wheel, Side Grip, Wheel Cover, Lock Nut Wrench



Continuous Rating Input Input Kuasa Berterusan 额定输入功率	1,100W
Wheel Diameter Diameter Roda 轮片直径	125mm (5")
No Load Speed (RPM) Kelajuan Tanpa Beban 回转数	11,000
Dimensions (L x W x H) Dimensi 体积	303x140x116mm (11-7/8"x5-1/2"x4-9/16")
Net Weight Berat Bersih 净重	2.4 - 3.5kg (5.2 - 7.8lbs)
Power Supply Cord Kabel Wayar 电源线	2.5m (8.2ft)

Cordless
Tempa Kord 充电式

LED Flashlight
Lampu Cahaya LED
LED照明灯

Vacuum Cleaner
Pembersih Vakum
吸尘器

Drilling / Fastening
Cairul / Pasang
钻孔 / 紧固

Impact Drilling / Demolition
Cairul / Penebuk
冲击钻孔 / 拆毁施工

Cutting
Pembahagian
切割

Grinding / Sanding
Pangkas / Poles
研磨 / 打磨

Sawing
Gergaji
锯切

Planing / Routing
Pegyalan / Tunggam
刨削 / 雕刻

Others
Lain-lain
其他

Outdoor Power Equipment
Alatan Kuat Luar
户外动力工具

Makita
MAKITA

GRINDING | SANDING

Cordless
Tanpa Kabel Listrik

LED Flashlight
Lampu Senter LED

Vacuum Cleaner
Pembersih Vakuum

Drilling | Fastening
Gardu | Pasang

Impact Drilling | Demolition
Gardu | Perusakan

Cutting
Pemotongan

Grinding | Sanding
Pengkilan | Pasir

Sawing
Gergaji

Planing | Routing
Pengaliran | Tenggang

Others
Lain-lain

Outdoor Power Equipment
Alat-alat Luar

Makita
Makita

GA5080R 125mm (5")

318 WATT

Angle Grinder Pengisar Sudut 角向磨光机



Slide Switch Suis Gelasar 滑动开关

- **X-LOCK for toolless accessory changes**
X-LOCK untuk perubahan aksesoris tanpa alat
免工具更换配件的 X-LOCK



Standard Equipment: Depressed Center Wheel (E-00402), Side Grip, Wheel Cover



Continuous Rating Input Input Kuasa Berterusan 额定输入功率	1,400W
Wheel Diameter Diameter Roda 轮片直径	125mm (5")
Max Wheel Thickness Ketebalan Roda Maksimum 最大轮片厚度	6mm (1/4")
Max Cutting Depth Kedalaman Pemotongan Maksimum 最大切削深度	31mm (1-1/4")
No Load Speed (RPM) Kelajuan Tanpa Beban 回转速数	12,000
Dimensions (L x W x H) Dimensi 体积	309x141x113mm (12-1/8x5-9/16x4-7/16")
Net Weight Berat Bersih 净重	2.5 - 3.6kg (5.5 - 7.9lbs.)
Power Supply Cord Kabel Wayar 电源线	2.5m (8.2ft)

GA5041C 125mm (5")

318 WATT

Angle Grinder Pengisar Sudut 角向磨光机



Slide Switch Suis Gelasar 滑动开关

- **Super Joint System II developed for effective vibration absorption**
SJS generasi kedua berkesan untuk menyerap getaran
第二代 SJS 有效抑止震动



Standard Equipment: Depressed Center Wheel, Side Grip, Wheel Cover, Lock Nut Wrench



Continuous Rating Input Input Kuasa Berterusan 额定输入功率	1,400W
Wheel Diameter Diameter Roda 轮片直径	125mm (5")
No Load Speed (RPM) Kelajuan Tanpa Beban 回转速数	2,800-11,000
Dimensions (L x W x H) Dimensi 体积	325x140x121mm (12-3/4"x5-1/2"x4-3/4")
Net Weight Berat Bersih 净重	2.7 - 3.8kg (5.9 - 8.4lbs)
Power Supply Cord Kabel Wayar 电源线	2.5m (8.2ft)

9565CR / PC 125mm (5")

318 WATT

Angle Grinder Pengisar Sudut 角向磨光机



9565CR Slide Switch Suis Gelasar 滑动开关

- **SJS Mechanical Clutch System Helps Prevent Motor and Gear Damage**
Sistem SJS mencegah kerosakan pada motor dan gear
SJS 系统有助于防止马达和齿轮损坏



Standard Equipment:
9565CR: Depressed Center Wheel (B-56390), Side Grip, Wheel Cover, Lock Nut Wrench
9565PC: Side Grip, Wheel Cover, Lock Nut Wrench



Continuous Rating Input Input Kuasa Berterusan 额定输入功率	1,400W
Wheel Diameter Diameter Roda 轮片直径	125mm (5")
No Load Speed (RPM) Kelajuan Tanpa Beban 回转速数	12,000
Dimensions (L x W x H) Dimensi 体积	299x139x103mm 9565CR (11-3/4"x5-1/2"x4-1/16") 307x139x103mm 9565PC (12-1/8"x5-1/2"x4")
Net Weight Berat Bersih 净重	2.4 - 3.5kg (5.2 - 7.7lbs)
Power Supply Cord Kabel Wayar 电源线	2.5m (8.2ft)

Recommended Accessories
Grinding Wheel for Heavy Industries
Depressed Center Wheel (B-56390)
125 x 7.2mm



GA6010 150mm (6")

303 WATT

Angle Grinder Pengisar Sudut 角向磨光机



Trigger Switch Suis Pemicu 扳机开关

- **Powerful 1,050W motor**
Motor berkuasa 1,050W
强力1,050W马达



Standard Equipment: Depressed Center Wheel (A-80846), Side Grip, Wheel Cover, Lock Nut Wrench



Continuous Rating Input Input Kuasa Berterusan 额定输入功率	1,050W
Wheel Diameter Diameter Roda 轮片直径	150mm (6")
No Load Speed (RPM) Kelajuan Tanpa Beban 回转速数	10,000
Dimensions (L x W x H) Dimensi 体积	356x169x112mm (14"x6-5/8"x4-3/8")
Net Weight Berat Bersih 净重	2.7 - 3.1kg (5.9 - 6.9lbs)
Power Supply Cord Kabel Wayar 电源线	2.5m (8.2ft)

GRINDING | SANDING

GA6020C 150mm (6")

253

Angle Grinder
Pengisar Sudut
角向磨光机



Trigger Switch
Suis Pemicu 扳机开关

- **Electric current limiter protects motor from overload**
Pembatasan arus elektrik melindungi motor dari kelebihan beban
电流限制器保护马达免超负荷



Standard Equipment: Depressed Center Wheel (A-80846), Side Grip, Wheel Cover, Lock Nut Wrench



Continuous Rating Input Input Kuasa Berterusan 额定输入功率	1,450W
Wheel Diameter Diameter Roda 轮片直径	150mm (6")
No Load Speed (RPM) Kelajuan Tanpa Beban 回转数	9,000
Dimensions (L x W x H) Dimensi 体积	390x169x120mm (15-3/8"x6-5/8"x4-3/4")
Net Weight Berat Bersih 淨重	3.0 - 3.5kg (6.7 - 7.6lbs)
Power Supply Cord Kabel Wayar 电源线	2.5m (8.2ft)



GA7050 180mm (7")

204

Angle Grinder
Pengisar Sudut
角向磨光机



Trigger Switch
Suis Pemicu 扳机开关

- **Most compact in its class**
Paling padat dalam kelasnya
在同类中最紧凑



Standard Equipment: Side Grip, Wheel Cover, Lock Nut Wrench



Continuous Rating Input Input Kuasa Berterusan 额定输入功率	2,000W
Wheel Diameter Diameter Roda 轮片直径	180mm (7")
No Load Speed (RPM) Kelajuan Tanpa Beban 回转数	8,500
Dimensions (L x W x H) Dimensi 体积	432x200x132mm (17"x7-7/8"x5-3/16")
Net Weight Berat Bersih 淨重	3.98 - 5.00kg (8.8 - 11.0lbs)
Power Supply Cord Kabel Wayar 电源线	2.5m (8.2ft)

GA7063R 180mm (7")

218

Angle Grinder
Pengisar Sudut
角向磨光机

Trigger Switch
Suis Pemicu 扳机开关

- **D-Handle protects operator's hand from materials**
Pemegang D melindungi tangan pengguna dari bahan
D型把手保护使用者的手远离物料



Standard Equipment: Side Grip, Wheel Cover, Lock Nut Wrench



Continuous rating input Panjang Strok 冲程长度	2,200W
Wheel Diameter Kelajuan Strok 冲程速度	180mm (7")
No Load Speed (RPM) Kapasiti 能力	8,500
Dimensions (L x W x H) Dimensi 体积	450x200x145mm (17-3/4"x7-7/8"x5-3/4")
Net weight Berat Bersih 淨重	5.70 - 6.21kg (12.6 - 13.7lbs)
Power supply cord	2.5m (8.2ft)



Cordless
Tempa Kord 充电式

LED Flashlight
Lampu Suhu LED
LED照明灯

Vacuum Cleaner
Pembersih Vakuum
吸尘器

Drilling / Fastening
Cairul / Pengikat
钻孔 / 紧固

Impact Drilling / Demolition
Cairul / Pengikat
冲击钻孔 / 拆除施工

Cutting / Finishing
Pangkas / Hias
切割 / 打磨

Grinding / Sanding
Pangkas / Hias
打磨 / 砂磨

Sawing / Chiseling
Gergaji
锯切

Planing / Routing
Pangkas / Hias
刨平 / 铣削

Others
Lain-lain
其他

Outdoor Power Equipment
Alatan Kuasa Luar
户外动力设备

Makita
工具专家

GRINDING | SANDING

GA7062 180mm (7")

218

Angle Grinder

Pengisar Sudut
角向磨光机

Trigger Switch

Suis Pemicu 扳机开关

- Developed for heavy duty applications such as **foundry grinding**

Sesuai untuk aplikasi tugas berat
适合重型应用, 如铸造磨削加工



Standard Equipment: Side Grip, Wheel Cover, Lock Nut Wrench



Continuous Rating Input Input Kuasa Berterusan 额定输入功率	2,200W
Wheel Diameter Diameter Roda 轮片直径	180mm (7")
No Load Speed (RPM) Kelajuan Tanpa Beban 回转数	8,500
Dimensions (L x W x H) Dimensi 体积	450x200x144mm (17-3/4"x7-7/8"x5-5/8")
Net Weight Berat Bersih 净重	5.51 - 6.02kg (12.2 - 13.3lbs)
Power Supply Cord Kabel Wayar 电源线	2.5m (8.2ft.)

GA7061R 180mm (7")

218

Angle Grinder

Pengisar Sudut
角向磨光机

Trigger Switch

Suis Pemicu 扳机开关

- Developed for heavy duty applications such as **foundry grinding**

Ringan untuk mengurangkan keletihan, meningkatkan produksi dengan berkesan
轻量不易引起疲劳, 有效的增加工作量



Standard Equipment: Side Grip, Wheel Cover, Lock Nut Wrench



Continuous Rating Input Input Kuasa Berterusan 额定输入功率	2,200W
Wheel Diameter Diameter Roda 轮片直径	180mm (7")
No Load Speed (RPM) Kelajuan Tanpa Beban 回转数	8,500
Dimensions (L x W x H) Dimensi 体积	450x200x145mm (17-3/4"x7-7/8"x5-3/4")
Net Weight Berat Bersih 净重	5.57 - 6.08kg (12.3 - 13.4lbs)
Power Supply Cord Kabel Wayar 电源线	2.5m (8.2ft.)

GA7060R 180mm (7")

218

Angle Grinder

Pengisar Sudut
角向磨光机

Trigger Switch

Suis Pemicu 扳机开关

- Developed for heavy duty applications such as **foundry grinding**

Sesuai untuk aplikasi tugas berat
适合重型应用, 如铸造磨削加工



Standard Equipment: Side Grip, Wheel Cover, Lock Nut Wrench



Continuous Rating Input Input Kuasa Berterusan 额定输入功率	2,200W
Wheel Diameter Diameter Roda 轮片直径	180mm (7")
No Load Speed (RPM) Kelajuan Tanpa Beban 回转数	8,500
Dimensions (L x W x H) Dimensi 体积	450x200x144mm (17-3/4"x7-7/8"x5-5/8")
Net Weight Berat Bersih 净重	5.42 - 5.93kg (12 - 13.1lbs)
Power Supply Cord Kabel Wayar 电源线	2.5m (8.2ft.)

GA7060 180mm (7")

218

Angle Grinder

Pengisar Sudut
角向磨光机

Trigger Switch

Suis Pemicu 扳机开关

- Motor more durable for heavy duty applications**
Motor lebih tahan lama untuk aplikasi tugas berat
马达更耐用



Standard Equipment: Side Grip, Wheel Cover, Lock Nut Wrench



Continuous Rating Input Input Kuasa Berterusan 额定输入功率	2,200W
Wheel Diameter Diameter Roda 轮片直径	180mm (7")
No Load Speed (RPM) Kelajuan Tanpa Beban 回转数	8,500
Dimensions (L x W x H) Dimensi 体积	450x200x144mm (17-3/4"x7-7/8"x5-5/8")
Net Weight Berat Bersih 净重	5.38 - 5.89kg (11.9 - 13lbs)
Power Supply Cord Kabel Wayar 电源线	2.5m (8.2ft.)

GA7020 180mm (7")

204

Angle Grinder

Pengisar Sudut
角向磨光机

Trigger Switch

Suis Pemicu 扳机开关

- Powerful 2,200W Motor for Faster Material Removal**

Motor berkuasa 2,200W untuk pengisaran yang lebih cepat
功率强大的 2,200W 马达提供更快的研磨



Standard Equipment: Side Grip, Wheel Cover, Lock Nut Wrench



Continuous Rating Input Input Kuasa Berterusan 额定输入功率	2,200W
Wheel Diameter Diameter Roda 轮片直径	180mm (7")
No Load Speed (RPM) Kelajuan Tanpa Beban 回转数	8,500
Dimensions (L x W x H) Dimensi 体积	473x200x140mm (18-5/8"x7-7/8"x5-1/2")
Net Weight Berat Bersih 净重	5.56 - 6.06kg (12.26 - 13.36lbs)
Power Supply Cord Kabel Wayar 电源线	2.5m (8.2ft.)

Cordless
Tanggap Hood 角磨机

LED Flashlight
Lampu Suluh LED
LED 照明灯

Vacuum Cleaner
Pembersih Vakuum
吸尘器

Drilling / Fastening
Qandul / Pengikat
钻孔 / 紧固

Impact Drilling / Demolition
Qandul / Penceroboh
起工钻孔 / 拆除加工

Cutting
Pemotong
切割

Grinding / Sanding
Pengisar / Pasir
打磨 / 磨光

Sawing
Gergaji
锯切

Planing / Routing
Pengaliran / Tanggapan
刨削 / 雕刻

Others
Lain-lain
其他

Outdoor Power Equipment
Alatan Kuasa Luar
园具-户外

Makita
MAKITA

GRINDING | SANDING

GA7070 180mm (7")

Angle Grinder
Pengisar Sudut
角向磨光机



Trigger Switch
Suis Pemicu 扳机开关

- Motor more durable for heavy duty applications



Standard Equipment: Anti-Vibration Grip, Wheel Cover, Lock Nut Wrench



Continuous Rating Input Input Kuasa Berterusan 额定输入功率	2,800W
Wheel Diameter Diameter Roda 轮片直径	180mm (7")
Wheel Hole Diameter Diameter Lubang Roda 轮片孔直径	22.23mm (7/8")
Max Wheel Thickness Ketebalan Roda Maksimum 最大轮片厚度	7.2mm (1/4")
No Load Speed (RPM) Kelajuan Tanpa Beban 回转数	8,500
Dimensions (L x W x H) Dimensi 体积	506x200x146mm (20x7-7/8x5-3/4")
Net Weight Berat Bersih 净重	6.1 - 6.6kg (13.5 - 14.6lbs.)
Power Supply Cord Kabel Wayar 电源线	2.5m (8.2ft)



GA9050 230mm (9")

204

Angle Grinder
Pengisar Sudut
角向磨光机



Trigger Switch
Suis Pemicu 扳机开关

- Compact gear housing increases maximum cutting depth by 4mm
Kotak gear padat untuk meningkatkan kedalaman pemotongan maksimum kepada 4mm
紧凑的齿轮箱增加最大切割深度至4mm



Standard Equipment: Side Grip, Wheel Cover, Lock Nut Wrench



Continuous Rating Input Input Kuasa Berterusan 额定输入功率	2,000W
Wheel Diameter Diameter Roda 轮片直径	230mm (9")
No Load Speed (RPM) Kelajuan Tanpa Beban 回转数	6,600
Dimensions (L x W x H) Dimensi 体积	432x250x132mm (17"x9-7/8"x5-3/16")
Net Weight Berat Bersih 净重	4.64 - 6.94kg (10.2 - 15.3lbs)
Power Supply Cord Kabel Wayar 电源线	2.5m (8.2ft)

GA9061R 230mm (9")

218

Angle Grinder
Pengisar Sudut
角向磨光机



Trigger Switch
Suis Pemicu 扳机开关

- Motor more durable for heavy duty applications
Motor lebih tahan lama untuk aplikasi tugas berat
马达更耐用



Standard Equipment: Side Grip, Wheel Cover, Lock Nut Wrench



Continuous Rating Input Input Kuasa Berterusan 额定输入功率	2,200W
Wheel Diameter Diameter Roda 轮片直径	230mm (9")
No Load Speed (RPM) Kelajuan Tanpa Beban 回转数	6,600
Dimensions (L x W x H) Dimensi 体积	450x250x145mm (17-3/4"x9-7/8"x5-3/4")
Net Weight Berat Bersih 净重	5.68 - 8.04kg (12.5 - 17.7lbs)
Power Supply Cord Kabel Wayar 电源线	2.5m (8.2ft)

GA9060R 230mm (9")

218

Angle Grinder
Pengisar Sudut
角向磨光机



Trigger Switch
Suis Pemicu 扳机开关

- Powerful 2,200W motor
Motor berkuasa 2,200W
强力2,200W马达



Standard Equipment: Side Grip, Wheel Cover, Lock Nut Wrench



Continuous Rating Input Input Kuasa Berterusan 额定输入功率	2,200W
Wheel Diameter Diameter Roda 轮片直径	230mm (9")
No Load Speed (RPM) Kelajuan Tanpa Beban 回转数	6,600
Dimensions (L x W x H) Dimensi 体积	450x250x144mm (17-3/4"x9-7/8"x5-5/8")
Net Weight Berat Bersih 净重	5.52 - 7.88kg (12.8 - 17.4lbs)
Power Supply Cord Kabel Wayar 电源线	2.5m (8.2ft)

Cordless
Tanpa Kord 无线式

LED Flashlight
Lampu Suluh LED
LED照明灯

Vacuum Cleaner
Pembersih Vakuum
吸尘器

Drilling / Fastening
Cairul / Pengikat
钻孔 / 紧固

Impact Drilling / Demolition
Cairul / Pembongkaran
冲击钻孔 / 拆毁施工

Cutting / Finishing
Pangkas / Finishing
切割 / 打磨

Grinding / Sanding
Pangkas / Poles
打磨 / 研磨

Sawing / Cutting
Gergaji
锯切

Planing / Routing
Perataan / Tunggam
刨削 / 压花

Others
Lain-lain
其他

Outdoor Power Equipment
Alatan Kuasa Luar
户外动力设备

Thakita
TENT

GRINDING | SANDING

GA9060 230mm (9")

218 

Angle Grinder Pengisar Sudut 角向磨光机



Trigger Switch

Suis Pemicu 扳机开关

- **Motor more durable for heavy duty applications**
Motor lebih tahan lama untuk aplikasi tugas berat
马达更耐用



Standard Equipment: Side Grip, Wheel Cover, Lock Nut Wrench



Continuous Rating Input Input Kuasa Berterusan 额定输入功率	2,200W
Wheel Diameter Diameter Roda 轮片直径	230mm (9")
No Load Speed (RPM) Kelajuan Tanpa Beban 回转数	6,600
Dimensions (L x W x H) Dimensi 体积	450x250x144mm (17-3/4"x9-7/8"x5-5/8")
Net Weight Berat Bersih 淨重	5.50 - 7.86kg (12.1 - 17.3lbs)
Power Supply Cord Kabel Wayar 电源线	2.5m (8.2ft)

GA9020 230mm (9")

204 

Angle Grinder Pengisar Sudut 角向磨光机



Trigger Switch

Suis Pemicu 扳机开关

- **Spiral bevel gears more efficient transfer of energy**
Gear serong lingkaran untuk pemindahan tenaga yang lebih cekap
螺旋锥齿轮高效输送能源



Standard Equipment: Side Grip, Wheel Cover, Lock Nut Wrench



Continuous Rating Input Input Kuasa Berterusan 额定输入功率	2,200W
Wheel Diameter Diameter Roda 轮片直径	230mm (9")
No Load Speed (RPM) Kelajuan Tanpa Beban 回转数	6,000
Dimensions (L x W x H) Dimensi 体积	473x249x140mm (18-5/8"x9-3/4"x5-1/2")
Net Weight Berat Bersih 淨重	5.76 - 8.05kg (12.7 - 17.8lbs)
Power Supply Cord Kabel Wayar 电源线	2.5m (8.2ft)

GA9070 230mm (9")

Angle Grinder Pengisar Sudut 角向磨光机



Trigger Switch

Suis Pemicu 扳机开关

- **Motor more durable for heavy duty applications**



Standard Equipment: Anti-Vibration Grip, Wheel Cover, Lock Nut Wrench



Continuous Rating Input Input Kuasa Berterusan 额定输入功率	2,800W
Wheel Diameter Diameter Roda 轮片直径	230mm (9")
Wheel Hole Diameter Diameter Lubang Roda 轮片孔直径	22.23mm (7/8")
Max Wheel Thickness Ketebalan Roda Maksimum 最大轮片厚度	6.5mm (1/4")
No Load Speed (RPM) Kelajuan Tanpa Beban 回转数	6,600
Dimensions (L x W x H) Dimensi 体积	506x250x146mm (20x9-7/8x5-3/4")
Net Weight Berat Bersih 淨重	6.3 - 8.5kg (13.9 - 18.7lbs.)
Power Supply Cord Kabel Wayar 电源线	2.5m (8.2ft)



SA5040C 125mm (5")

318 

Angle Sander Pengampelas Sudut 角向抛光机



- **Electronic current limiter prevents motor burnout due to overloading**
Pengehad arus elektronik mencegah motor dari terbakar yang disebabkan oleh beban lampau
电子电流限制器可防止超负荷引起的马达烧毁



Standard Equipment: Pad, Side Grip, Head Cover



Continuous Rating Input Input Kuasa Berterusan 额定输入功率	1,400W
Wheel Diameter Diameter Roda 轮片直径	125mm (5")
Capacity Kapasiti 能力	Pad : 115mm (4-1/2")
No Load Speed (RPM) Kelajuan Tanpa Beban 回转数	2,000-7,800
Dimensions (L x W x H) Dimensi 体积	315x115x121mm (12-3/8"x4-1/2"x4-3/4")
Net Weight Berat Bersih 淨重	2.5 - 3.7kg (5.5 - 8.2lbs)
Power Supply Cord Kabel Wayar 电源线	2.5m (8.2ft)

Cordless
Tanggap Hood 角磨机LED Flashlight
Lampu Suluh LED
LED 照明灯Vacuum Cleaner
Pembersih Vakuum
吸尘器Drilling | Fastening
Ganda | Pengikat
钻孔 | 紧固Impact Drilling | Demolition
Ganda | Penembak
冲击钻孔 | 拆除加工Cutting
Pemotong
切割Grinding | Sanding
Pengisar | Poles
磨削 | 打磨Sawing
Ganda
切割Planing | Routing
Pengaliran | Tanggapan
刨削 | 雕刻Others
Lain-lain
其他Outdoor Power Equipment
Alatan Kuasa Luar
园机-户外Makita
MAKITA

GRINDING | SANDING

PK5001C 125mm (5")

318

Angle Sander Pengampelas Sudut 角向抛光机



- **Ideal one for effective stone polishing**
Untuk penggilap batu yang berkesan
有效的石材抛光

Standard Equipment: Side Grip, Lock Nut Wrench



Continuous Rating Input Input Kuasa Berterusan 额定输入功率	1,400W
Wheel Diameter Diameter Roda 轮片直径	125mm (5")
Capacity Kapasiti 能力	Pad : 115mm (4-1/2")
No Load Speed (RPM) Kelajuan Tanpa Beban 回转数	2,000-6,800
Dimensions (L x W x H) Dimensi 体积	328x80x126mm (12-7/8"x3-1/8"x5")
Net Weight Berat Bersih 净重	2.4 - 2.9kg (5.3 - 6.4lbs)
Power Supply Cord Kabel Wayar 电源线	4.0m (13.1ft)

GV5010 125mm (5")

64

Disc Sander Pelicin Piring 盘式砂光机



- **For faster and easier removal of paint/ rust**
Untuk penyingkiran cat / karat yang lebih cepat dan mudah
更快, 更容易去除油漆/锈蚀

Standard Equipment: Abrasive Disc, Plastic Pad, Side Grip, Hex socket head bolt, Washer, Hex Wrench



Continuous Rating Input Input Kuasa Berterusan 额定输入功率	440W
Abrasive Disc Size Saiz Cakera 磨盘尺寸	125mm (5")
Capacity Kapasiti 能力	Pad: 120mm (4-3/4")
No Load Speed (RPM) Kelajuan Tanpa Beban 回转数	4,500
Dimensions (L x W x H) Dimensi 体积	200x74x181mm (7-7/8"x2-15/16"x7-1/8")
Net Weight Berat Bersih 净重	1.2kg (2.6lbs)
Power Supply Cord Kabel Wayar 电源线	2.5m (8.2ft)

GV6010 150mm (6")

64

Disc Sander Pelicin Piring 盘式砂光机



- **Powerful 440W motor for fast material removal**
Motor berkuasa 440W untuk penyingkiran bahan cepat
功率强劲的440W马达

Standard Equipment: Abrasive Disc, Plastic Pad, Side Grip, Hex socket head bolt, Washer, Hex Wrench



Continuous Rating Input Input Kuasa Berterusan 额定输入功率	440W
Abrasive Disc Size Saiz Cakera 磨盘尺寸	150mm (6")
Capacity Kapasiti 能力	Pad: 120mm (4-3/4")
No Load Speed (RPM) Kelajuan Tanpa Beban 回转数	4,500
Dimensions (L x W x H) Dimensi 体积	200x74x181mm (7-7/8"x2-15/16"x7-1/8")
Net Weight Berat Bersih 净重	1.2kg (2.6lbs)
Power Supply Cord Kabel Wayar 电源线	2.5m (8.2ft)

GV7000C 180mm (7")

303

Disc Sander Pelicin Piring 盘式砂光机



- **Motor-over-pad design for better balance and control**
Reka bentuk motor-over-pad untuk keseimbangan dan kawalan yang lebih baik
更好的平衡易于控制

Standard Equipment: Abrasive Disc, Rubber Pad, Lock Nut Wrench, Wrench, Side Grip



Continuous Rating Input Input Kuasa Berterusan 额定输入功率	900W
Abrasive Disc Size Saiz Cakera 磨盘尺寸	180mm (7")
Capacity Kapasiti 能力	Pad: 180mm (7")
No Load Speed (RPM) Kelajuan Tanpa Beban 回转数	2,500-4,700
Overall Length Panjang Keseluruhan 总长度	210mm (8-1/4")
Net Weight Berat Bersih 净重	2.1kg (4.6lbs)
Power Supply Cord Kabel Wayar 电源线	2.5m (8.2ft)

9215SB 150mm (6")

100

Disc Sander Pelicin Piring 盘式砂光机



- **Powerful motor in well-balanced body for fast and steady sanding**
Motor berkuasa dengan badan yang seimbang
强劲的马达平衡良好及机身

Standard Equipment: Rubber Pad, Lock Nut Wrench, Wrench, Side Grip



Continuous Rating Input Input Kuasa Berterusan 额定输入功率	570W
Wire Cup Brush Berus Wayar Cawan 杯型钢丝刷	110mm (4-3/8")
Abrasive Disc Size Saiz Cakera 磨盘尺寸	150mm (6")
No Load Speed (RPM) Kelajuan Tanpa Beban 回转数	4,500
Overall Length Panjang Keseluruhan 总长度	225mm (8-7/8")
Net Weight Berat Bersih 净重	2.9kg (6.3lbs)
Power Supply Cord Kabel Wayar 电源线	2.5m (8.2ft)

Cordless
Tempat Akord 充电式

LED Flashlight
Lampu Cahaya LED
LED照明灯

Vacuum Cleaner
Pembersih Vakuum
吸尘器

Drilling / Fastening
Cairul / Pengikat
钻孔 / 紧固

Impact Drilling / Demolition
Cairul / Penebuk
冲击钻孔 / 拆毁动工

Cutting / Finishing
Pangkas / Hias
切割

Grinding / Sanding
Pangkas / Poles
研磨 / 砂磨

Sawing / Cutting
Gergaji
锯切

Planing / Routing
Pangkas / Tunggam
刨削 / 雕刻

Others
Lain-lain
其他

Outdoor Power Equipment
Alatan Kuasa Luar
户外动力设备

Thakita
工具

GRINDING | SANDING

9237C 180mm (7")

303

Polisher Penggilap 打蜡机



- **Fast and powerful for clear coat finishes**
Cepat dan berkuasa untuk kemasan kot yang jelas
快速清除涂层



Standard Equipment: Side Handle, Hex Wrench, Wool Pad



Continuous Rating Input Input Kuasa Berterusan 额定输入功率	1,200W
Capacity Kapasiti 能力	Wool Pad: 180mm (7") Wool Bonnet: 180mm (7")
No Load Speed (RPM) Kelajuan Tanpa Beban 回转数	0 - 3,200
Dimensions (L x W x H) Dimensi 体积	431x198x187mm (17"x7-3/4"x7-3/8")
Net Weight Berat Bersih 净重	3.2 - 3.4kg (7.0 - 7.5lbs)
Power Supply Cord Kabel Wayar 电源线	2.5m (8.2ft)

PO5000C 125mm (5")

318

Random Orbit Polisher Pelicin Orbit 砂光机



- **Wide variety of optional accessories (Pad, Sponge pad, Felt pad, Wool pad)**
Pelbagai aksesori pilihan (pad, pad sponge, pad felt, pad bulu)
各种可选配件 (垫, 海绵垫, 毡垫, 羊毛垫)



PO5000C/PO6000C
Models and specs may vary by country

Standard Equipment: Hex Wrench



Continuous Rating Input Input Kuasa Berterusan 额定输入功率	900W
Pad Size Saiz Pad 垫子尺寸	125mm (5")
Orbits Per Minute (OPM) Bilangan Putaran 轨道转速	0 - 6,800
Strokes Per Minute (SPM) Kelajuan Strok 冲程速度	0 - 13,600
No Load Speed (RPM) Kelajuan Tanpa Beban 回转数	0 - 780
Orbit Diameter Kelajuan Tanpa Beban 回转数	5.5 mm (7/32")
Dimensions (L x W x H) Dimensi 体积	451x123x134mm (17-3/4"x4-7/8"x5-1/4")
Net Weight Berat Bersih 净重	2.8 - 3.0kg (6.2 - 6.5lbs)
Power Supply Cord Kabel Wayar 电源线	4.0m (13.1ft)

PO6000C 150mm (6")

318

Random Orbit Polisher Pelicin Orbit 砂光机



- **Wide variety of optional accessories (Pad, Sponge pad, Felt pad, Wool pad)**
Pelbagai aksesori pilihan (pad, pad sponge, pad felt, pad bulu)
各种可选配件 (垫, 海绵垫, 毡垫, 羊毛垫)



PO5000C/PO6000C
Models and specs may vary by country

Standard Equipment: Hex Wrench



Continuous Rating Input Input Kuasa Berterusan 额定输入功率	900W
Pad Size Saiz Pad 垫子尺寸	150mm (6")
Orbits Per Minute (OPM) Bilangan Putaran 轨道转速	0 - 6,800
Strokes Per Minute (SPM) Kelajuan Strok 冲程速度	0 - 13,600
No Load Speed (RPM) Kelajuan Tanpa Beban 回转数	0 - 780
Orbit Diameter Kelajuan Tanpa Beban 回转数	5.5mm (7/32")
Dimensions (L x W x H) Dimensi 体积	451x148x126mm (17-3/4"x5-7/8"x5")
Net Weight Berat Bersih 净重	2.8 - 3.0kg (6.2 - 6.5lbs)
Power Supply Cord Kabel Wayar 电源线	4.0m (13.1ft)

PV7000C 180mm (7")

303

Polisher Penggilap 抛光机



- **Lightweight for reduced operator fatigue**
Ringan untuk mengurangkan keletihan pengguna
轻量不易引起疲劳



Standard Equipment: Side Handle, Pad, Wrench



Continuous Rating Input Input Kuasa Berterusan 额定输入功率	900W
Capacity Kapasiti 能力	Pad: 180mm (7") Wool Bonnet: 180mm (7")
No Load Speed (RPM) Kelajuan Tanpa Beban 回转数	600 - 2,100
Overall Length Panjang Keseluruhan 总长度	210mm (8-1/4")
Net Weight Berat Bersih 净重	2.1kg (4.6lbs)
Power Supply Cord Kabel Wayar 电源线	2.5m (8.2ft)

GD0600 6mm (1/4")

325

Die Grinder Gerinda Lurus 电磨



- **Large Flush-Mount Paddle Switch for Comfortable Operation**
Suis Flush-mount mudah digunakan
大型平装式按钮开关易于操作



Standard Equipment: Wrench x2



Continuous Rating Input Input Kuasa Berterusan 额定输入功率	400W
Capacity Kapasiti 能力	Collet: 3mm (1/8") or 6mm (1/4")
Wheel Diameter Diameter Roda 轮片直径	38mm (1-1/2")
No Load Speed (RPM) Kelajuan Tanpa Beban 回转数	25,000
Dimensions (L x W x H) Dimensi 体积	358x82x82mm (14-1/8"x3-1/4"x3-1/4")
Net Weight Berat Bersih 净重	1.71 - 1.87kg (3.77 - 4.12lbs)
Power Supply Cord Kabel Wayar 电源线	2.5m (8.2ft)

GRINDING | SANDING

GD0601 6mm (1/4")

325

Die Grinder

Gerinda Lurus
电磨



- **Powerful 400W motor**
Motor berkuasa 400W
强力400W马达



Standard Equipment: [Wrench x2](#)



Continuous Rating Input Input Kuasa Berterusan 额定输入功率	400W
Capacity Kapasiti 能力	Collet: 3mm (1/8") or 6mm (1/4")
Wheel Diameter Diameter Roda 轮片直径	38mm (1-1/2")
No Load Speed (RPM) Kelajuan Tanpa Beban 回转数	25,000
Dimensions (L x W x H) Dimensi 体积	359x82x82mm (14-1/8"x3-1/4"x3-1/4")
Net Weight Berat Bersih 净重	1.68 - 1.84kg (3.70 - 4.06lbs)
Power Supply Cord Kabel Wayar 电源线	2.5m (8.2ft)

GD0603 6mm (1/4")

64

Die Grinder

Gerinda Lurus
电磨



- **Compact and easy handling**
Padat dan mudah digunakan
紧凑且易于使用



Standard Equipment: [Spanner](#), [Wheel points](#)



Continuous Rating Input Input Kuasa Berterusan 额定输入功率	240W
Capacity Kapasiti 能力	Collet: 6mm (1/4")
Max Wheel Diameter Diameter Roda 轮片直径	19mm (3/4")
No Load Speed (RPM) Kelajuan Tanpa Beban 回转数	28,000
Diameter of Grip Diameter Silinder 圆筒直径	65mm
Dimensions (L x W x H) Dimensi 体积	289x64x67mm (11-3/8"x2-1/2"x2-5/8")
Net Weight Berat Bersih 净重	0.98kg (2.16lbs)
Power Supply Cord Kabel Wayar 电源线	2.5m (8.2ft)

GD0800C 6mm (1/4")

318

Die Grinder

Gerinda Lurus
电磨



- **Electronic Controller for Operator Convenience**
Pengawal elektronik untuk kemudahan pengguna
电子控制器方便使用者



Standard Equipment: [Wrench x2](#)



Continuous Rating Input Input Kuasa Berterusan 额定输入功率	750W
Capacity Kapasiti 能力	Collet: 3mm (1/8") or 6mm (1/4")
Wheel Diameter Diameter Roda 轮片直径	25mm (1")
No Load Speed (RPM) Kelajuan Tanpa Beban 回转数	7,000-28,000
Dimensions (L x W x H) Dimensi 体积	371x75x75mm (14-5/8"x2-15/16"x2-15/16")
Net Weight Berat Bersih 净重	1.88kg (4.14lbs)
Power Supply Cord Kabel Wayar 电源线	2.5m (8.2ft)

GD0801C 6mm (1/4")

318

Die Grinder

Gerinda Lurus
电磨



- **Powerful 750W motor for faster material removal**
Motor berkuasa 750W untuk pengisaran yang lebih cepat
功率强大的 750W 马达提供更快的研磨



Standard Equipment: [Side Handle](#), [Wrench x2](#)



Continuous Rating Input Input Kuasa Berterusan 额定输入功率	750W
Capacity Kapasiti 能力	Collet: 6mm (1/4")
Max Wheel Diameter Diameter Roda 轮片直径	25mm (1")
No Load Speed (RPM) Kelajuan Tanpa Beban 回转数	7,000-29,000
Dimensions (L x W x H) Dimensi 体积	390x75x88mm (15-3/8"x2-15/16"x3-1/2")
Net Weight Berat Bersih 净重	1.96 - 1.97kg (4.32 - 4.34lbs)
Power Supply Cord Kabel Wayar 电源线	2.5m (8.2ft)

GD0811C 6mm (1/4")

318

Die Grinder

Gerinda Lurus
电磨



- **Ideal for grinding internal surfaces, removing paint etc. using with flap wheel**
Sesuai untuk mengisar permukaan dalaman, cat dan lain-lain
适用于研磨内表面, 使用皮瓣轮去除油漆等



Standard Equipment: [Side Handle](#), [Wrench x2](#)



Continuous Rating Input Input Kuasa Berterusan 额定输入功率	750W
Capacity Kapasiti 能力	Collet: 6mm (1/4")
Max Wheel Diameter Diameter Roda 轮片直径	50mm (2")
No Load Speed (RPM) Kelajuan Tanpa Beban 回转数	1,800-7,000
Dimensions (L x W x H) Dimensi 体积	390x75x88mm (15-3/8"x2-15/16"x3-1/2")
Net Weight Berat Bersih 净重	1.99 - 2.00kg (4.39 - 4.41lbs)
Power Supply Cord Kabel Wayar 电源线	2.5m (8.2ft)

Cordless
Tempa Kord 无线式

LED Flashlight
Lampu Cahaya LED
LED照明灯

Vacuum Cleaner
Pembersih Vakuum
吸尘器

Drilling / Fastening
Cairul / Pengikat
钻孔 / 紧固

Impact Drilling / Demolition
Cairul / Pengikat
石工钻孔 / 拆毁动工

Cutting
Pembahagian
切割

Grinding / Sanding
Pangkas / Poles
研磨 / 砂磨

Sawing
Gergaji
锯切

Planing / Routing
Peyataan / Tunggam
刨削 / 雕刻

Others
Lain-lain
其他

Outdoor Power Equipment
Alatan Kuasa Luar
户外动力设备

Thakita
TENTU

GRINDING | SANDING

GS5000 125mm (5")

204 W

Straight Grinder

Pengisar Lurus
直向砂轮机



- **Powerful 750W motor**
Motor berkuasa 750W
强力750W马达



Standard Equipment: Hex Wrench, Wrench



Continuous Rating Input Input Kuasa Berterusan 额定输入功率	750W
Wheel Diameter Diameter Roda 轮片直径	125mm (5")
Hole Diameter Diameter Lubang 孔直径	12.7, 20mm (1/2, 13/16")
No Load Speed (RPM) Kelajuan Tanpa Beban 回转数	5,600
Dimensions (L x W x H) Dimensi 体积	590x189x116mm (23-1/4"x8-7/16"x4-9/16")
Net Weight Berat Bersih 净重	5.0 - 5.2kg (11.0 - 11.5lbs)
Power Supply Cord Kabel Wayar 电源线	2.5m (8.2ft)

GS6000 150mm (6")

204 W

Straight Grinder

Pengisar Lurus
直向砂轮机



- **Powerful 750W motor**
Motor berkuasa 750W
强力750W马达



Standard Equipment: Hex Wrench, Wrench



Continuous Rating Input Input Kuasa Berterusan 额定输入功率	750W
Wheel Diameter Diameter Roda 轮片直径	150mm (6")
Hole Dia. Diameter Lubang 孔直径	12.7, 20mm (1/2, 13/16")
No Load Speed (RPM) Kelajuan Tanpa Beban 回转数	5,600
Dimensions (L x W x H) Dimensi 体积	590x216x130mm (23-1/4"x8-1/2"x5-1/8")
Net Weight Berat Bersih 净重	5.2 - 5.4kg (11.4 - 12.0lbs)
Power Supply Cord Kabel Wayar 电源线	2.5m (8.2ft)

TM3000C

459 W

Multi Tool

Mesin Pemotong Berbilang Fungsi
多功能切割打磨机



- **Powerful 320W motor with improved performance**
Motor berkuasa 320W dengan prestasi yang lebih baik
强力320W马达，改进的性能



Standard Equipment: Hex Wrench



Continuous Rating Input Input Kuasa Berterusan 额定输入功率	320W
Strokes Per Minute (SPM) Kelajuan Strok 冲程速度	6,000-20,000
Dimensions (L x W x H) Dimensi 体积	275x64x92mm (10-7/8"x2-1/2"x3-5/8")
Net Weight Berat Bersih 净重	1.4 - 1.5kg (3.2 - 3.3lbs)
Power Supply Cord Kabel Wayar 电源线	5.0m (16.4ft)



TM3000C/TM40D/TM50D

Models and specs may vary by country

TM3010CX6

459 W

Multi Tool

Mesin Pemotong Berbilang Fungsi
多功能切割打磨机



- **Toolless clamp system for fast accessory installation**
Sistem pemasangan aksesori tanpa alat
免工具快速安装与更换配件



Standard Equipment: Multi Tool Plunge Cut Saw Blade 32, Segment Saw Blade 85, Sanding Pad



Bow Shape Plunge Cut Saw Blade 32

Segment Saw Blade 85

Sanding Pad

Continuous Rating Input Input Kuasa Berterusan 额定输入功率	320W
Strokes Per Minute (SPM) Kelajuan Strok 冲程速度	6,000-20,000
Dimensions (L x W x H) Dimensi 体积	283x68x87mm (11-1/8"x2-11/16"x3-7/16")
Net Weight Berat Bersih 净重	1.6 - 1.7kg (3.7 - 3.9lbs)
Power Supply Cord Kabel Wayar 电源线	2.5m (8.2ft)



TM3010C

Models and specs may vary by country

GB602 150mm (6")

Bench Grinder

Pengisar
台式砂轮机



- **Wheel covers have built-in task lights**
Lampu tugas terbina dalam pelindung roda
轮罩具有内置任务灯



Standard Equipment: Safety Eye Shield, Protection glasses, Wrench x2



Continuous Rating Input Input Kuasa Berterusan 额定输入功率	250W
Wheel Diameter Diameter Roda 轮片直径	150mm (6")
Wheel Width Lebar Roda 轮片宽度	16mm (5/8")
Hole Dia. Diameter Lubang 孔直径	12.7mm (1/2")
H.P.	1/3
No Load Speed (RPM) Kelajuan Tanpa Beban 回转数	2,850 (50Hz)/ 3,450 (60Hz)
Dimensions (L x W x H) Dimensi 体积	375x205x286mm (14-49/64"x8"x11-17/64")
Net Weight Berat Bersih 净重	9.31 - 9.08kg (20.02 - 20.52lbs)

GRINDING | SANDING

GB801 205mm (8")

Bench Grinder

Pengisar
台式砂轮机



- **Adjustable wheel balance feature reduces vibration**
Pelarasanimbangan roda mengurangi getaran
平衡调整减少振动

Standard Equipment: Safety Eye Shield, Protection glasses, Wrench x2



Continuous Rating Input Input Kuasa Berterusan 额定输入功率	550W
Wheel Diameter Diameter Roda 轮片直径	205mm (8")
Wheel Width Lebar Roda 轮片宽度	19mm (3/4")
Hole Dia. Diameter Lubang 孔直径	15.88mm (5/8")
H.P.	3/4
No Load Speed (RPM) Kelajuan Tanpa Beban 回转数	2,850 (50Hz)/ 3,450 (60Hz)
Dimensions (L x W x H) Dimensi 体积	395x265x333mm (15-9/16"x10-7/16"x13-7/64")
Net Weight Berat Bersih 净重	19.91 - 19.63kg (43.89 - 43.28lbs)

PC5010C 125mm (5")

318

Concrete Planer

Pengampelas
砂光机



- **Compact and Lightweight for High Production Work**
Kompak dan ringan untuk kerja pengeluaran yang tinggi
紧凑轻巧型, 更有效率地工作

Standard Equipment: Lock Nut Wrench



Continuous Rating Input Input Kuasa Berterusan 额定输入功率	1,400W
Wheel Diameter Diameter Roda 轮片直径	125mm (5")
Hole Diameter Diameter Lubang 孔直径	22.23mm (7/8")
No Load Speed (RPM) Kelajuan Tanpa Beban 回转数	4,000 - 9,000
Dimensions (L x W x H) Dimensi 体积	350x231x179mm (13-3/4"x9-1/8"x7")
Net Weight Berat Bersih 净重	2.5 - 3.6kg (5.5 - 7.9lbs.)
Power Supply Cord Kabel Wayar 电源线	4.0m (13.1ft)

PC5000C 125mm (5")

253

Concrete Planer

Pengampelas
砂光机



- **Electronic current limiter helps protect the motor from overload**
Pengehad arus elektronik melindungi motor daripada beban lampau
电子电流限制器有助于防止马达超负荷

Standard Equipment: Lock Nut Wrench, Hex Wrench, Dust Bag Assembly



Continuous Rating Input Input Kuasa Berterusan 额定输入功率	1,400W
Wheel Diameter Diameter Roda 轮片直径	125mm (5")
Hole Dia. Diameter Lubang 孔直径	22.23mm (7/8")
No Load Speed (RPM) Kelajuan Tanpa Beban 回转数	10,000
Dimensions (L x W x H) Dimensi 体积	437x235x195mm (17-1/8"x9-1/4"x7-5/8")
Net Weight Berat Bersih 净重	4kg (8.9lbs)
Power Supply Cord Kabel Wayar 电源线	5.0m (16.4ft)

PC5001C 125mm (5")

253

Concrete Planer

Pengampelas
砂光机



- **Soft start suppresses start-up reaction for more precision and longer tool life**
Penghidupan secara perlahan untuk ketepatan yang lebih baik dan memanjangkan hayat alat
缓速启动提高准确性和延长工具使用寿命

Standard Equipment: Lock Nut Wrench, Hex Wrench, Dust Bag Assembly



Continuous Rating Input Input Kuasa Berterusan 额定输入功率	1,400W
Wheel Diameter Diameter Roda 轮片直径	125mm (5")
No Load Speed (RPM) Kelajuan Tanpa Beban 回转数	10,000
Dimensions (L x W x H) Dimensi 体积	479x182x195mm (18-13/16"x7-1/8"x7-5/8")
Net Weight Berat Bersih 净重	4kg (8.9lbs)
Power Supply Cord Kabel Wayar 电源线	5m (16.4ft)

PW5001C 125mm (5")

318

Stone Polisher

Penggilap Batu
水磨石机



- **Variable speed control dial enables user to match the speed to the application**
Pilihan kawalan kelajuan berubah untuk pelbagai aplikasi
变速控制选择适合多种应用

Standard Equipment: Rubber Pad, Side Grip, Wrench, Head Cover



Continuous Rating Input Input Kuasa Berterusan 额定输入功率	900W
Capacity Kapasiti 能力	Pad: 100-125mm (4-5")
No Load Speed (RPM) Kelajuan Tanpa Beban 回转数	2,000-4,000
Overall Length Panjang Keseluruhan 总长度	359mm (14-1/8")
Net Weight Berat Bersih 净重	2.3 - 2.6kg (5.1 - 5.7lbs)
Power Supply Cord Kabel Wayar 电源线	4.0m (13.1ft)

Cordless
Tempa Kord 无线式

LED Flashlight
Lampu Cahaya LED
LED照明灯

Vacuum Cleaner
Pembersih Vakuum
吸尘器

Drilling / Fastening
Cairul / Pengikat
钻孔 / 紧固

Impact Drilling / Demolition
Cairul / Penebuk
石工钻孔 / 拆毁动工

Cutting
Pampasan
切割

Grinding / Sanding
Pengampelas / Paskah
研磨 / 砂磨

Sawing
Gergaji
锯切

Planing / Routing
Pergayaan / Tunggam
刨削 / 雕刻

Others
Lain-lain
其他

Outdoor Power Equipment
Alatan Kuasa Luar
户外动力

Makita
MAKITA

GRINDING | SANDING

Cordless
Tali Tali Tanpa Wayar

LED Flashlight
Lampu Cahaya LED
LED 釐燈

Vacuum Cleaner
Pembersih Vakum
塵吸機

Drilling | Fastening
Dremel | Pengetol
黏釘 | 膠釘

Impact Drilling | Demolition
Dremel | Penembak
釘工黏釘 | 擊擊加工

Cutting
Pemotong
切割

Grinding | Sanding
Pengraai | Pasir
磨削 | 磨邊

Sawing
Gergaji
鋸切

Planing | Routing
Pengaliran | Tanggapan
磨削 | 磨邊

Others
Lain-lain
其他

Outdoor Power Equipment
Alatan Kerja Luar
園林-戶外

Makita
MAKITA

9404 100mm x 610mm (4" x 24")

303 WMI

Belt Sander Pengampelas 带式砂光机



- **Powerful 1,010W motor for fast material removal**
Motor berkuasa 1,010W untuk pengisaran yang lebih cepat
功率强大的 1.010W 马达提供更快的研磨



Standard Equipment: Abrasive Belt, Dust bag assembly



Continuous Rating Input Input Kuasa Berterusan 额定输入功率	1,010W
Belt Size Saiz Tali Pinggang 皮带尺寸	100 x 610mm (4" x 24")
Belt Speed Kelajuan Tali Pinggang 皮带速度	210-440m/min (690-1,440ft/min)
Overall Length Panjang Keseluruhan 总长度	334mm (13-1/8")
Net Weight Berat Bersih 淨重	4.8kg (10.6lbs)
Power Supply Cord Kabel Wayar 电源线	5.0m (16.4ft)

9903 76mm x 533mm (3" x 21")

303 WMI

Belt Sander Pengampelas 带式砂光机



- **Sands wood or metal and removes paint and rust**
Melicinkan kayu atau logam, menghilangkan cat dan karat
打磨木头或金属，去除油漆和铁锈



Standard Equipment: Abrasive Belt, Dust bag assembly



Continuous Rating Input Input Kuasa Berterusan 额定输入功率	1,010W
Belt Size Saiz Tali Pinggang 皮带尺寸	76 x 533mm (3" x 21")
Belt Speed Kelajuan Tali Pinggang 皮带速度	210 - 440m/min (690 - 1,440 ft/min)
Overall Length Panjang Keseluruhan 总长度	296mm (11-5/8")
Net Weight Berat Bersih 淨重	4.3kg (9.5lbs)
Power Supply Cord Kabel Wayar 电源线	5.0m (16.4ft)

9401 100mm x 610mm (4" x 24")

153 WMI

Belt Sander Pengampelas 带式砂光机



- **Highly-efficient dust collection system for clean work environment**
Sistem pengumpulan habuk yang cekap untuk mewujudkan persekitaran kerja bersih
高效的集尘系统打造清洁工作环境



Standard Equipment: Abrasive Belt, Carbon Plate, Step, Dust bag assembly



Continuous Rating Input Input Kuasa Berterusan 额定输入功率	940W
Belt Size Saiz Tali Pinggang 皮带尺寸	100 x 610mm (4" x 24")
Belt Speed Kelajuan Tali Pinggang 皮带速度	350m/min (1,150ft/min)
Overall Length Panjang Keseluruhan 总长度	374mm (14-3/4")
Net Weight Berat Bersih 淨重	7.2kg (15.9lbs)
Power Supply Cord Kabel Wayar 电源线	5.0m (16.4ft)

9924DB 76mm x 610mm (3" x 24")

100 WMI

Belt Sander Pengampelas 带式砂光机



- **Powerful 850W for fast material removal**
Motor berkuasa 750W untuk pengisaran yang lebih cepat
功率强大的 750W 马达提供更快的研磨



Standard Equipment: Abrasive Belt, Carbon Plate, Dust bag assembly



Continuous Rating Input Input Kuasa Berterusan 额定输入功率	850W
Belt Size Saiz Tali Pinggang 皮带尺寸	76 x 610, 620mm (3" x 24, 24-3/8")
Belt Speed Kelajuan Tali Pinggang 皮带速度	400m/min (1,300ft/min)
Overall Length Panjang Keseluruhan 总长度	355mm (14")
Net Weight Berat Bersih 淨重	4.8kg (10.6lbs)
Power Supply Cord Kabel Wayar 电源线	5.0m (16.4ft)

9911 76mm x 457mm (3" x 18")

411 WMI

Belt Sander Pengampelas 带式砂光机



- **Compact and well balanced for easy operation**
Padat dan mudah digunakan
紧凑且易于使用



Standard Equipment: Abrasive Belt, Dust bag assembly



Sementara stok masih ada
WHILE STOCK LAST
可購完為止

Continuous Rating Input Input Kuasa Berterusan 额定输入功率	650W
Belt Size Saiz Tali Pinggang 皮带尺寸	76 x 457mm (3" x 18")
Belt Speed Kelajuan Tali Pinggang 皮带速度	75 - 270m/min (250 - 900ft/min)
Overall Length Panjang Keseluruhan 总长度	262mm (10-3/8")
Net Weight Berat Bersih 淨重	2.7kg (6lbs)
Power Supply Cord Kabel Wayar 电源线	2.5m (8.2ft)

GRINDING | SANDING

9031 30mm x 533mm (1-3/16" x 21")

411

Belt Sander

Pengampelas
带式砂光机



- Versatile for use on wood, metal, and fiberglass materials
- Digunakan pada bahan kayu, logam, dan gentian kaca
- 多用于木材、金属和纤维玻璃材料



Standard Equipment: Abrasive Belt x10, Side Handle



Continuous Rating Input Input Kuasa Berterusan 额定输入功率	550W
Belt Size Saiz Tali Pinggang 皮带尺寸	30 x 533mm (1-1/8" x 21")
Belt Speed Kelajuan Tali Pinggang 皮带速度	200 - 1,000m/min (656 - 3,280ft/min)
Overall Length Panjang Keseluruhan 总长度	380mm (15")
Net Weight Berat Bersih 净重	2.1kg (4.6lbs)
Power Supply Cord Kabel Wayar 电源线	2.5m (8.2ft)

BO3710

64

Finishing Sander

Pengampelas
砂光机



- High capacity dust bag with built-in vacuum adaptor for improved dust collection
- Beg debu kapasiti tinggi dengan penyesuai vakum terbina dalam untuk pengumpulan habuk yang lebih baik
- 内置真空适配器的高容量集尘袋可改进集尘效果



Standard Equipment: Dust Bag, Punch Plate



Continuous Rating Input Input Kuasa Berterusan 额定输入功率	190W
Pad Size Saiz Pad 垫子尺寸	93 x 185mm (3-5/8" x 7-1/4")
Abrasive Paper Size Saiz Kertas Pasir 砂纸尺寸	93 x 228mm (3-5/8" x 9")
Orbits Per Minute (OPM) Bilangan Putaran 轨道转速	11,000
Strokes Per Minute (SPM) Kelajuan Strok 冲程速度	22,000
Orbit Diameter Jejaki Diameter 轨道直径	2.0mm (1/16")
Dimensions (L x W x H) Dimensi 体积	253x92x154mm (10"x3-5/8"x6-1/16")
Net Weight Berat Bersih 净重	1.6kg (3.5lbs)
Power Supply Cord Kabel Wayar 电源线	2.0m (6.6ft)

9035H

419

Finishing Sander

Pengampelas
砂光机



- Rubberized large paper clamp levers for easy installation/ removal of paper
- Batang pengapit getah yang besar memudahkan pemasangan dan penyingkiran kertas pasir
- 大号橡胶夹杆方便安装及取出砂纸



Standard Equipment: Abrasive paper x6



Continuous Rating Input Input Kuasa Berterusan 额定输入功率	180W
Pad Size Saiz Pad 垫子尺寸	93 x 185mm (3-5/8" x 7-1/4")
Abrasive Paper Size Saiz Kertas Pasir 砂纸尺寸	93 x 228mm (3-5/8" x 9")
Orbits Per Minute (OPM) Kelajuan Ayunan 摆动速度	11,000
Dimensions (L x W x H) Dimensi 体积	236x93x146mm (9-1/4"x3-5/8"x5-3/4")
Net Weight Berat Bersih 净重	1.5kg (3.3lbs)
Power Supply Cord Kabel Wayar 电源线	2.5m (8.2ft)

BO4901

419

Finishing Sander

Pengampelas
砂光机



- Large clamp lever for easy install/ removal of paper
- Batang pengapit yang besar memudahkan pemasangan dan penyingkiran kertas pasir
- 大夹紧杆方便安装及取出砂纸



Standard Equipment: Abrasive Paper



Continuous Rating Input Input Kuasa Berterusan 额定输入功率	330W
Pad Size Saiz Pad 垫子尺寸	115 x 229mm (4-1/2" x 9")
Abrasive Paper Size Saiz Kertas Pasir 砂纸尺寸	115 x 280mm (4-1/2" x 11")
Orbits Per Minute (OPM) Kelajuan Ayunan 摆动速度	10,000
Overall Length Panjang Keseluruhan 总长度	289mm (11-3/8")
Net Weight Berat Bersih 净重	2.8kg (6.2lbs)
Power Supply Cord Kabel Wayar 电源线	2.5m (8.2ft)

9045B 114mm (4-1/2")

105

Finishing Sander

Pengampelas
砂光机



- All bearing construction for smooth, long term operation
- Konstruksi gais yang sesuai untuk operasi lancar dan jangka panjang
- 适合平滑及长期运行的轴承结构



Standard Equipment: Abrasive paper x10



Continuous Rating Input Input Kuasa Berterusan 额定输入功率	520W
Pad Size Saiz Pad 垫子尺寸	114 x 234mm (4-1/2" x 9-1/4")
Abrasive Paper Size Saiz Kertas Pasir 砂纸尺寸	114 x 280mm (4-1/2" x 11")
Orbits Per Minute (OPM) Kelajuan Ayunan 摆动速度	10,000
Overall Length Panjang Keseluruhan 总长度	240mm (9-1/2")
Orbit Diameter Jejaki Diameter 轨道直径	2.4mm (3/32")
Net Weight Berat Bersih 净重	2.6kg (5.7lbs)
Power Supply Cord Kabel Wayar 电源线	2.5m (8.2ft)

Cordless
Tempat Akod 充电式

LED Flashlight
Lampu Suluh LED
LED照明灯

Vacuum Cleaner
Pembersih Vakum
吸尘器

Drilling / Fastening
Cairul / Pasang
钻孔 / 紧固

Impact Drilling / Demolition
Cairul / Pasang
石工钻孔 / 摧毁动工

Cutting
Panasah
切割

Grinding / Sanding
Pangkas / Pasah
研磨 / 砂磨

Sawing
Gajit
锯切

Planing / Routing
Pangkas / Tunggam
刨削 / 雕刻

Others
Lain-lain
其他

Outdoor Power Equipment
Alatan Kuat Luar
户外动力工具

makita
Makita

GRINDING | SANDING

Cordless
Turret Head 炮台式

LED Flashlight
Lampu Suluh LED
LED 照明灯

Vacuum Cleaner
Pembersih Vakuum
吸尘器

Drilling | Fastening
Ganjal | Pemasang
钻孔 | 紧固

Impact Drilling | Demolition
Ganjal | Penembok
冲击钻孔 | 拆除加工

Cutting
Pemotong
切割

Grinding | Sanding
Pengamir | Pasir
打磨 | 磨光

Sawing
Gergaji
锯切

Planing | Routing
Pengaliran | Tempam
刨削 | 雕刻

Others
Lain-lain
其他

Outdoor Power Equipment
Alat-alat Listrik
园林-户外

Makita
1915

BO4510H

419 W

Finishing Sander Pengampelas 砂光机



• **Large clamp lever for easy install/ removal of paper**

Batang pengapit yang besar memudahkan pemasangan dan penyingkiran kertas pasir
大夹紧杆方便安装及取出砂纸

Standard Equipment: Abrasive paper x6



Continuous Rating Input Input Kuasa Berterusan 额定输入功率	170W
Pad Size Saiz Pad 垫子尺寸	110 x 100mm (4-5/16" x 3-15/16")
Abrasive Paper Size Saiz Kertas Pasir 砂纸尺寸	114 x 140mm (4-1/2" x 5-1/2")
Orbits Per Minute (OPM) Bilangan Putaran 轨道转速	12,000
Dimensions (L x W x H) Dimensi 体积	116x110x129mm (4-9/16"x4-5/16"x5-1/8")
Net Weight Berat Bersih 净重	1.1kg (2.4lbs)
Power Supply Cord Kabel Wayar 电源线	2.5m (8.2ft)

BO4556

419 W

Finishing Sander Pengampelas 砂光机



• **14,000OPM for fast and smooth finish sanding**
14,000OPM untuk pelicinan cepat dan lancar
14,000OPM可快速平顺的打磨

Standard Equipment: Abrasive Paper, Dust Bag, Punch Plate



Continuous Rating Input Input Kuasa Berterusan 额定输入功率	200W
Pad Size Saiz Pad 垫子尺寸	112 x 102mm (4-3/8" x 4")
Abrasive Paper Size Saiz Kertas Pasir 砂纸尺寸	114 x 140mm (4-1/2" x 5-1/2")
Orbits Per Minute (OPM) Bilangan Putaran 轨道转速	14,000
Dimensions (L x W x H) Dimensi 体积	131x112x141mm (5-1/8"x4-3/8"x5-9/16")
Net Weight Berat Bersih 净重	1.1kg (2.5lbs)
Power Supply Cord Kabel Wayar 电源线	2.0m (6.6ft)

BO6050J

325 W

Random Orbit Sander Pengampelas 砂光机



• **Slim skirt provides higher work efficiency in tight spaces**
Kecekapan kerja yang lebih tinggi di ruang yang sempit
在狭小空间中提供更高的工作效率

Standard Equipment:
Abrasive Paper, Side Grip



VIDEO CLIP
Models and specs may vary by country



Continuous Rating Input Input Kuasa Berterusan 额定输入功率	750W
Pad Diameter Saiz Pad 垫子尺寸	150mm (6")
Abrasive Disc Size Saiz Cakera 磨盘尺寸	150mm (6")
Orbits Per Minute (OPM) Bilangan Putaran 轨道转速	1,600 - 6,800
Sanding Strokes Per Minute (SPM) Menggilap Strok Seminit 每分钟打磨冲程	3,200 - 13,600
Pad Speed in Roto-orbit mode (rpm) Kelajuan Pad 垫速度	140 - 600
Orbit Diameter Jejaki Diameter 轨道直径	5.5mm (7/32")
Dimensions (L x W x H) Dimensi 体积	330x155x145mm (13"x6-1/8"x5-3/4")
Net Weight Berat Bersih 净重	2.6kg (5.7lbs)
Power Supply Cord Kabel Wayar 电源线	2.5m (8.2ft)

BO5031

419 W

Random Orbit Sander Pengampelas 砂光机



• **Smooth finish with variable speed control**
Kemasan lancar dengan kawalan kelajuan yang pelbagai
变速控制

Standard Equipment: Abrasive Paper, Dust Bag



Continuous Rating Input Input Kuasa Berterusan 额定输入功率	300W
Pad Diameter Saiz Pad 垫子尺寸	123mm (4-7/8")
Abrasive Disc Size Saiz Cakera 磨盘尺寸	125mm (5")
Orbits Per Minute (OPM) Bilangan Putaran 轨道转速	4,000-12,000
Dimensions (L x W x H) Dimensi 体积	153x123x153mm (6"x4-7/8"x6")
Net Weight Berat Bersih 净重	1.3kg (3lbs)
Power Supply Cord Kabel Wayar 电源线	2.0m (6.6ft)

BO5041

64 W

Random Orbit Sander Pengampelas 砂光机



• **More power for faster sanding and a smooth finish**
Lebih berkuasa untuk pelicinan cepat dan lancar
更快速的打磨

Standard Equipment: Abrasive Paper, Dust Bag



Continuous Rating Input Input Kuasa Berterusan 额定输入功率	300W
Pad Diameter Saiz Pad 垫子尺寸	123mm (4-7/8")
Abrasive Disc Size Saiz Cakera 磨盘尺寸	125mm (5")
Orbits Per Minute (OPM) Bilangan Putaran 轨道转速	4,000-12,000
Dimensions (L x W x H) Dimensi 体积	218x123x153mm (8-5/8"x4-7/8"x6")
Net Weight Berat Bersih 净重	1.4kg (3.1lbs)
Power Supply Cord Kabel Wayar 电源线	2.0m (6.6ft)

SAWING

LS1019L 260mm (10-1/4")

153

Slide Compound Miter Saw

Gergaji Kompaun Miter
斜断锯



- **Large turn base supports workpiece securely for increased stability**
Dasar besar untuk menyokong bahan kerja dengan stabil
大转动底座稳定地支撑工件

Standard Equipment: EFFICUT Saw Blade, Dust Bag, Triangular Rule, Vertical Vise, Hex Wrench



Continuous Rating Input Input Kuasa Berterusan 额定输入功率	1,510W
Blade Diameter Diameter Bilah 锯片直径	260mm (10-1/4")
Bevel Angle Sudut Bevel 斜角	48°L / 48°R
Miter Angle Sudut Miter 斜接角	60°L / 60°R
Max Cutting Capacity Kapasiti Pemotongan Maksimum 最大切割能力	Crown Molding Vertically Nested: 168mm (6-5/8") Crown Molding Lying Flat: 248mm (9-3/4") Base Board Against Fence: 133mm (5-1/4") Base Board Lying Flat: 305mm (12")
No Load Speed (RPM) Kelajuan Tanpa Beban 回转数	3,200
Dimensions (L x W x H) Dimensi 体积	805x644x660mm (31-3/4"x25-3/8"x26")
Net Weight Berat Bersih 净重	26.3kg (57.9lbs.)
Power Supply Cord Kabel Wayar 电源线	2.5m (8.2ft.)

LS1219L 305mm (12")

153

Slide Compound Miter Saw

Gergaji Kompaun Miter
斜断锯



- **Dual dust collection ports provide excellent dust extraction performance**
Dua pengumpul habuk untuk prestasi pengekstrakan habuk yang sangat baik
双重集尘口提供出色的除尘性能

Standard Equipment: TCT Saw Blade (B-67474), Vertical Vise, Hex Wrench, Triangular Rule, Dust Bag



Continuous Rating Input Input Kuasa Berterusan 额定输入功率	1,800W
Blade Diameter Diameter Bilah 锯片直径	305mm (12")
Hole Diameter Diameter Lubang 孔直径	European Countries: 30mm (1-3/16") Others: 25.4mm (1")
Angle Sudut 角度	Bevel 48° L / 48° R Miter 60° L / 60° R
Max Cutting Capacity Kapasiti Pemotongan Maksimum 最大切割能力	Crown Molding Vertically Nested: 203mm (8") Crown Molding Lying Flat: 320mm (12-5/8") Base Board Against Fence: 171mm (6-3/4") Base Board Lying Flat: 416mm (16-3/8")
No Load Speed (RPM) Kelajuan Tanpa Beban 回转数	3,200
Dimensions (L x W x H) Dimensi 体积	898x664x725mm (35-1/4"x26-1/8"x28-1/2")
Net Weight Berat Bersih 净重	29.5kg (65.0lbs)
Power Supply Cord Kabel Wayar 电源线	2.5m (8.2ft)

LS1018L 260mm (10-1/4")

JM23000123

Slide Compound Saw

Gergaji Kompaun Miter
斜断锯



- **Large cutting capacity in a compact design and less weight**
Kapasiti pemotongan besar dalam reka bentuk kompak dan ringan
设计紧凑，轻量，切割能力大

Standard Equipment: TCT Saw Blade (B-14277), Vertical Vise, Socket Wrench, Triangular Rule, Dust Bag, Holder assembly



Continuous Rating Input Input Kuasa Berterusan 额定输入功率	1,430W
Blade Diameter Diameter Bilah 锯片直径	255 - 260mm (10 - 10-1/4")
Miter Angle Sudut Miter 斜接角	47°L / 60°R
Bevel Angle Sudut Bevel 斜角	45°L / 45°R
Max Cutting Capacity Kapasiti Pemotongan Maksimum 最大切割能力	90°: 91 x 305mm (3-5/8" x 12") 45°: 91 x 215mm (3-5/8" x 8-1/2")
No Load Speed (RPM) Kelajuan Tanpa Beban 回转数	4,300
Dimensions (L x W x H) Dimensi 体积	825x536x633mm (32-1/2"x21-1/8"x25")
Net Weight Berat Bersih 净重	20.6kg (45.4lbs)
Power Supply Cord Kabel Wayar 电源线	2.5m (8.2ft)

LS1040 260mm (10-1/4")

153

Compound Miter Saw

Gergaji Kompaun Miter
斜断锯



- **Powerful 1,650W direct drive motor for improved performance**
Motor 1,650W yang berkuasa meningkatkan prestasi
功率强劲的1,650W直驱马达提高了性能

Standard Equipment: Socket Wrench, Dust Bag, Holder Set, Vertical Vise, Triangular Rule



Continuous Rating Input Input Kuasa Berterusan 额定输入功率	1,650W
Blade Diameter Diameter Bilah 锯片直径	260mm (10-1/4")
Miter Angle Sudut Miter 斜接角	45°L / 52°R
Bevel Angle Sudut Bevel 斜角	45°L
Max Cutting Capacity Kapasiti Pemotongan Maksimum 最大切割能力	90°: 90.5 x 95mm (3-9/16" x 3-3/4") 45°: 90.5 x 67mm (3-9/16" x 2-5/8")
No Load Speed (RPM) Kelajuan Tanpa Beban 回转数	4,600
Dimensions (L x W x H) Dimensi 体积	530x476x532mm (20-7/8"x18-3/8"x21")
Net Weight Berat Bersih 净重	12.4kg (27.3lbs)
Power Supply Cord Kabel Wayar 电源线	2.5m (8.2ft)

LS0714 190mm (7-1/2")

153

Slide Compound Saw

Gergaji Kompaun Miter
斜断锯



- **Compact and Lightweight for Increased Jobsite Portability**
Kompak dan Ringan
小巧轻便

Standard Equipment: Carbide-Tipped Saw Blade, Dust Bag, Holder Set, Vertical Vise, Triangular Rule



Continuous Rating Input Input Kuasa Berterusan 额定输入功率	1,010W
Blade Diameter Diameter Bilah 锯片直径	190mm (7-1/2")
Miter Angle Sudut Miter 斜接角	47°L / 57°R
Bevel Angle Sudut Bevel 斜角	45°L / 5°R
Max Cutting Capacity Kapasiti Pemotongan Maksimum 最大切割能力	90°: 52 x 300mm (2-1/16" x 11-3/4") 45°: 52 x 212mm (2-1/16" x 8-3/8")
No Load Speed (RPM) Kelajuan Tanpa Beban 回转数	6,000
Dimensions (L x W x H) Dimensi 体积	670x430x458mm (26-3/8"x17"x18")
Net Weight Berat Bersih 净重	13.1kg (28.9lbs)
Power Supply Cord Kabel Wayar 电源线	2.5m (8.2ft)

Cordless
Tape Aot 30.6ftLED Flashlight
Lampu Suka LED
LED照明灯Vacuum Cleaner
Penarik Vakuum
吸尘器Drilling / Fastening
Cairul / Pengikat
钻孔 / 紧固Impact Drilling / Demolition
Cairul / Pengikat
钻孔 / 拆除Cutting
Pemotong
切割Grinding / Sanding
Pengkilan / Pasir
打磨 / 砂磨Sawing
Cairul
锯切Planing / Routing
Polikan / Tinggapan
刨削 / 雕刻Others
Lain-lain
其他Outdoor Power Equipment
Alatan Kerja Luar
园机 / 户外Makita
MAKITA

SAWING

LH1201FL 305mm (12")

JM23000123

Table Top Miter Saw

Gergaji Miter
两用平台斜切锯



• 2 tools in 1 for convenience and versatility
Alat 2 dalam 1
1机2用

Standard Equipment: TCT Saw Blade, Vertical Vise, Dust Bag, Rip Fence, Ring, Triangular Rule, Push Stick, Blade Cover, Socket Wrench, Holder Set



Continuous Rating Input 1,650W

Input Kuasa Berterusan 额定输入功率

Blade Diameter 305mm (12")

Diameter Bilah 锯片直径

Miter Angle 47°L/ 52°R

Sudut Miter 斜接角

Bevel Angle 45°L

Sudut Bevel 斜角

Max Cutting Capacity 90°: 62 x 200mm (2-7/16" x 7-7/8")/ 90°: 95 x 155mm

Kapasiti Pemotongan Maksimum 最大切割能力
45° Miter, L/R: 62 x 135mm (2-7/16" x 5-5/16")/ 90°, Table saw: 52mm (2-1/16")

No Load Speed (RPM) 3,800

Kelajuan Tanpa Beban 回转数

Dimensions (L x W x H) 610x535x692mm (24"x21"x27-1/4")

Dimensi 体积
Table Size (W x L): 307 x 465mm (12-1/8" x 18-1/4")

Net Weight 20.9kg (46.1lbs)

Berat Bersih 净重

Power Supply Cord 2.5m (8.2ft)

Kabel Wayar 电源线

MAXIMUM CUTTING CAPACITY

Model No.	Base Angle	Blade Angle Left 45°	Blade Angle 0°	Blade Angle Right 5°	Blade Angle Right 45°
LS0714	0°	40x300mm	52x300mm	40x300mm	-
	Left / Right 45°	40x212mm	52x212mm	-	-
	Right 57°	-	52x163mm	-	-
LS1018L	0°	50x305mm	91x305mm	-	31x305mm
	Left / Right 45°	50x215mm	91x215mm	-	31x215mm
	Right 60°	-	91x150mm	-	-
LS1019L	0°	47x305, 61x279mm	71x305, 91x279mm	-	29x305, 43x279mm
	Left / Right 45°	47x215, 61x197mm	71x215, 91x197mm	-	29x215, 43x197mm
	Left / Right 60°	-	71x152, 91x139mm	-	-
LS1219L	0°	71x363mm	107x363mm	-	54x363mm
	Left / Right 45°	71x255mm	107x255mm	-	54x255mm
	Left / Right 60°	-	107x178mm	-	-
LS1040	0°	48x95mm	90.5x95mm	-	-
	Left / Right 45°	48x67mm	90.5x67mm	-	-
	-	-	-	-	-
LH1201FL	0°	64x155mm	95x155mm	-	-
	Left 45°	64x65mm	95x110mm	-	-
	Right 45°	40x125mm	95x110mm	-	-
Cutting capacity as table saw: 52mm					
LS1440	-	-	122x152mm	-	-
	-	-	122x115mm	-	-
	-	-	-	-	-
LS1030N	-	-	90.5x95mm	-	-
	-	-	90.5x67mm	-	-
	-	-	-	-	-
LF1000	-	-	20x210mm	-	-
	-	-	68x155mm	-	-
	-	-	50x150mm	-	-

LS1440 355mm (14")

153

Miter Saw

Gergaji Miter
斜断锯



• Large cutting capacity
Kapasiti pemotongan besar
大切割能力



Standard Equipment: Socket Wrench, Vise Assembly, Dust Bag, Holder Set



Continuous Rating Input 1,380W

Input Kuasa Berterusan 额定输入功率

Max Cutting Capacity 90°: 122 x 152mm (4-13/16" x 6")

Kapasiti Pemotongan Maksimum 最大切割能力
45°: 122 x 115mm (4-13/16" x 4-1/2")

Blade Diameter 355mm (14")

Diameter Bilah 锯片直径

No Load Speed (RPM) 3,200

Kelajuan Tanpa Beban 回转数

Dimensions (L x W x H) 530x596x435mm

Dimensi 体积
(20-7/8"x23-1/2"x17-1/8")

Net Weight 34.2kg (75.4lbs)

Berat Bersih 净重

Power Supply Cord 2.5m (8.2ft)

Kabel Wayar 电源线

Cordless
Tangan Kordless

LED Flashlight
Lampu Suluh LED
LED 照明灯

Vacuum Cleaner
Pembersih Vakum
吸尘器

Drilling / Fastening
Gergaji / Pengikat
钻孔 / 紧固

Impact Drilling / Demolition
Gergaji / Pemecah
冲击钻孔 / 拆除加工

Cutting
Pemotongan
切割

Grinding / Sanding
Hergaji / Habis
打磨 / 磨光

Planing / Routing
Pengaliran / Tanggapan
刨削 / 雕刻

Others
Lain-lain
其他

Outdoor Power Equipment
Alat-alat Tenaga Luar
园具 / 户外

Makita
Makita

SAWING

LS1030N 260mm (10-1/4")

153

Miter Saw Gergaji Miter 斜断锯

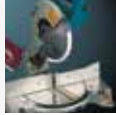

- Miter cuts 0°-45° left and 0°-52° right
Serong 0° -45° ke kiri dan 0° -52° ke kanan
斜切向左 0° -45° 和向右 0° -52°



Standard Equipment: Socket Wrench, Dust Bag, Triangular Rule



Continuous Rating Input Input Kuasa Berterusan 额定输入功率	1,650W
Blade Diameter Diameter Bilah 锯片直径	260mm (10-1/4")
Max Cutting Capacity Kapasiti Pemotongan Maksimum 最大切割能力	90°: 90.5 x 95mm (3-9/16" x 3-3/4") 45°: 90.5 x 67mm (3-9/16" x 2-5/8")
No Load Speed (RPM) Kelajuan Tanpa Beban 回转速数	4,600
Dimensions (L x W x H) Dimensi 体积	530x476x532mm (20-7/8"x18-3/4"x21")
Net Weight Berat Bersih 净重	12.1kg (26.7lbs.)
Power Supply Cord Kabel Wayar 电源线	2.5m (8.2ft)

LF1000 260mm (10-1/4")

153

Flip Over Saw Gergaji Flip 翻转锯



- Quick miter saw/ table saw conversion
Konversi gergaji miter & gergaji meja
斜断锯及台锯快速转换



Standard Equipment: Rip Fence, Miter Gauge, Push Stick, Top Cover Assy (Top Blade Guard), Dust Cover, Dust Bag, Wrench 8



Continuous Rating Input Input Kuasa Berterusan 额定输入功率	1,650W
Max Cutting Capacity Kapasiti Pemotongan Maksimum 最大切割能力	90°: 20 x 210mm (13/16" x 8-1/4") 90°: 68 x 155mm (2-11/16" x 6-1/8") 45°: 50 x 150mm (2" x 5-7/8")
Blade Diameter Diameter Bilah 锯片直径	260mm (10-1/4")
No Load Speed (RPM) Kelajuan Tanpa Beban 回转速数	2,700
Dimensions (L x W x H) Dimensi 体积	Miter saw : 660x650x1,220mm (26"x25-1/2"x48") Table saw : 660x650x1,060mm (26"x25-1/2"x41-3/4")
Net Weight Berat Bersih 净重	36.0 kg (79.4 lbs)
Power Supply Cord Kabel Wayar 电源线	2.5 m (8.2 ft)

2704 260mm (10-1/4")

153

Table Saw Gergaji Meja 台锯



- Electric brake for increased productivity and operator safety
Brek Elektrik untuk peningkatan produktiviti dan pengendalian keselamatan
电子自动刹车提高生产率和操作安全



Standard Equipment: Carbide-Tipped Saw Blade (B-17734), Rip Fence, Miter Gauge, Wrenches, Push Stick, Ring



Continuous Rating Input Input Kuasa Berterusan 额定输入功率	1,650W
Max Cutting Capacity Kapasiti Pemotongan Maksimum 最大切割能力	90°: 93mm (3-5/8") 45°: 64mm (2-1/2")
Blade Diameter Diameter Bilah 锯片直径	260mm (10-1/4")
No Load Speed (RPM) Kelajuan Tanpa Beban 回转速数	4,800
Dimensions (L x W x H) Dimensi 体积	665x766x344mm (26-1/4"x30-1/4"x13-1/2")
Net Weight Berat Bersih 净重	35.6 - 37.3kg (78.5 - 82.3lbs.)
Power Supply Cord Kabel Wayar 电源线	2.5m (8.2ft)

MLT100 260mm (10-1/4")

Table Saw Gergaji Meja 台锯



- Right and rear extension table enables greater cutting capacity
Meja tambahan kanan dan belakang membolehkan kapasiti pemotongan yang lebih besar
右侧和后侧延伸台具有更大的切割能力



Standard Equipment: Carbide-Tipped Saw Blade, Rip Fence, Miter Gauge, Wrenches, Push Stick, Triangular Rule



Continuous rating input Input Kuasa Berterusan 额定输入功率	1,500W
Max Cutting Capacity Kapasiti Pemotongan Maksimum 最大切割能力	90°: 91mm (3-9/16") 45°: 63mm (2-1/2")
Blade Diameter Diameter Bilah 锯片直径	260mm (10-1/4")
No Load Speed (RPM) Kelajuan Tanpa Beban 回转速数	4,300
Dimensions (L x W x H) Dimensi 体积	726x984x333mm (28-1/2"x38-3/4"x13-1/8")
Net weight Berat Bersih 净重	34.1kg (75.2lbs)
Power supply cord Kabel Wayar 电源线	2.5m (8.2ft)

Cordless
Tenggak 30.6ALED Flashlight
Lampu Suluh LED
LED照明灯Vacuum Cleaner
Penarik Debu Vacuum
吸尘器Drilling / Fastening
Cairul / Pengikat
钻孔 / 紧固Impact Drilling / Demolition
Cairul / Penakut
钻孔/ 拆土Cutting
Pemotong
切割Grinding / Sanding
Pengkilan / Pasir
打磨 / 砂磨Sawing
Cairul
锯切Planing / Routing
Polikan / Tinggapan
刨削 / 雕刻Others
Lain-lain
其他Outdoor Power Equipment
Alatan Kuasa Luar
户外动力工具Makita
MAKITA

SAWING

2712 315mm (12-3/8")

Table Saw

Gergaji Meja
台锯



- **Powerful 2,000W motor for fast cutting**
Motor berkuasa 2,000W untuk pemotongan pantas
功能强大的2,000W马达快速切割

Standard Equipment: Carbide-Tipped Saw Blade, Rip Fence, Miter Gauge, Wrenches, Push Stick, Ring



Max Cutting Capacity Kapasiti Pemotongan Maksimum 最大切割能力	90°: 85mm (3-3/8") 45°: 58mm (2-1/4")
Blade Diameter Diameter Bilah 锯片直径	315mm (12-3/8")
No Load Speed (RPM) Kelajuan Tanpa Beban 回转速	50Hz: 2,950 60Hz: 3,400
Bevel Capacity Kapasiti Bevel 斜角容量	0° - 45°
Dimensions (L x W x H) Dimensi 体积	1,670x700x810mm (65-3/4"x27-1/2"x32")
Net weight Berat Bersih 淨重	54kg (118.9lbs)
Power supply cord Kabel Wayar 电源线	3.0m (9.8ft)

HS6100 165mm (6-1/2")

174 W

Circular Saw

Gergaji Piring
圆锯



- **Smooth cutting at high rotational speed**
Pemotongan licin pada kelajuan putaran tinggi
在高转速下平滑切割

Standard Equipment: Carbide-Tipped Saw Blade (B-02917), Hex Wrench, Rip Fence (Guide Rule), Dust Nozzle (195801-0)



Continuous Rating Input Input Kuasa Berterusan 额定输入功率	1,100W
Blade Diameter Diameter Bilah 锯片直径	165mm (6-1/2")
Max Cutting Capacity Kapasiti Pemotongan Maksimum 最大切割能力	90°: 54.5mm (2-1/8")/ 45°: 39.5mm (1-9/16")/ 50°: 35.5mm (1-3/8")
No Load Speed (RPM) Kelajuan Tanpa Beban 回转速	5,500
Dimensions (L x W x H) Dimensi 体积	297x246x246mm (11-3/4"x9-11/16"x9-11/16")
Net Weight Berat Bersih 淨重	3.5kg (7.7lbs)
Power Supply Cord Kabel Wayar 电源线	2.5m (8.2ft)

HS6600 165mm (6-1/2")

303 W

Circular Saw

Gergaji Piring
圆锯



- **More compact and lightweight design**
Reka bentuk lebih padat dan ringan
更小巧轻便的设计

Standard Equipment: Rip Fence (Guide Rule), TCT Saw Blade (B-02917), Hex Wrench



Continuous Rating Input Input Kuasa Berterusan 额定输入功率	1,050W
Blade Diameter Diameter Bilah 锯片直径	165mm (6-1/2")
Max Cutting Capacity Kapasiti Pemotongan Maksimum 最大切割能力	90°: 54.5mm (2-1/8") 45°: 37.5mm (1-1/2")
No Load Speed (RPM) Kelajuan Tanpa Beban 回转速	5,200
Dimensions (L x W x H) Dimensi 体积	296x230x243mm (11-5/8"x9"x9-9/16")
Net Weight Berat Bersih 淨重	3.5kg (7.6lbs)
Power Supply Cord Kabel Wayar 电源线	2.5m (8.2ft)

HS7010 185mm (7-1/4") / 190mm (7-1/2")

303 W

Circular Saw

Gergaji Piring
圆锯



- **High Power and Increased Motor-Burnout Resistance**
Berkuasa Tinggi
高功率

Standard Equipment: TCT Saw Blade, Rip Fence (Guide Rule), Hex Wrench



Continuous Rating Input Input Kuasa Berterusan 额定输入功率	1,600W
Blade Diameter Diameter Bilah 锯片直径	185/ 190mm (7-1/4"/ 7-1/2")
Max Cutting Capacity Kapasiti Pemotongan Maksimum 最大切割能力	90°: 65/ 67mm (2-9/16"/ 2-5/8") 45°: 44/ 45mm (1-3/4"/ 1-3/4")
No Load Speed (RPM) Kelajuan Tanpa Beban 回转速	5,500
Dimensions (L x W x H) Dimensi 体积	300x240x261mm (11-3/4"x9-1/2"x10-1/4")
Net Weight Berat Bersih 淨重	4.0kg (8.9lbs)
Power Supply Cord Kabel Wayar 电源线	2.5m (8.2ft)

HS7600 185mm (7-1/4")

303 W

Circular Saw

Gergaji Piring
圆锯



- **Powerful 1,200W motor**
Motor berkuasa 1,200W
动力1,200W马达

Standard Equipment: TCT Saw Blade, Rip Fence (Guide Rule), Hex Wrench



Continuous Rating Input Input Kuasa Berterusan 额定输入功率	1,200W
Blade Diameter Diameter Bilah 锯片直径	185mm (7-1/4")
Max Cutting Capacity Kapasiti Pemotongan Maksimum 最大切割能力	90°: 64mm (2-1/2") 45°: 42mm (1-5/8")
No Load Speed (RPM) Kelajuan Tanpa Beban 回转速	5,200
Dimensions (L x W x H) Dimensi 体积	309x234x255mm (12-1/8"x9-1/4"x10")
Net Weight Berat Bersih 淨重	3.8kg (8.3lbs)
Power Supply Cord Kabel Wayar 电源线	2.5m (8.2ft)

SAWING

5806B 185mm (7-1/4")

303

Circular Saw Gergaji Piring 圆锯



- **Powerful motor for smooth operation even in heavy duty cutting**
Motor berkuasa untuk operasi lancar walaupun dalam pemotongan tugas berat
强大的马达即使在重型切割中也可以平稳运行

Standard Equipment: Carbide-Tipped Saw Blade, Hex Wrench, Rip Fence (Guide Rule)



Continuous Rating Input Input Kuasa Berterusan 额定输入功率	1,050W
Blade Diameter Diameter Bilah 锯片直径	185mm (7-1/4")
Max Cutting Capacity Kapasiti Pemotongan Maksimum 最大切割能力	90°: 66mm (2-5/8") 45°: 44mm (1-11/16")
No Load Speed (RPM) Kelajuan Tanpa Beban 回转数	5,200
Overall Length Panjang Keseluruhan 总长度	282mm (11-1/8")
Net Weight Berat Bersih 净重	3.5kg (7.6lbs)
Power Supply Cord Kabel Wayar 电源线	2.5m (8.2ft)

5008MG 210mm (8-1/4")

153

Circular Saw Gergaji Piring 圆锯



- **Powerful 1,800W motor for proven performance**
Motor berkuasa 1,800W untuk prestasi yang terbukti
功率强大的1,800W马达，性能可靠

Standard Equipment: TCT Saw Blade (D-29066), Hex Wrench, Rip Fence (Guide Rule)



Continuous Rating Input Input Kuasa Berterusan 额定输入功率	1,800W
Blade Diameter Diameter Bilah 锯片直径	210mm (8-1/4")
Max Cutting Capacity Kapasiti Pemotongan Maksimum 最大切割能力	90°: 75.5mm (3") 45°: 57mm (2-1/4") 50°: 51.5mm (2")
No Load Speed (RPM) Kelajuan Tanpa Beban 回转数	5,200
Dimensions (L x W x H) Dimensi 体积	332x243x277mm (13-1/8"x9-9/16"x10-7/8")
Net Weight Berat Bersih 净重	4.8kg (10.6lbs)
Power Supply Cord Kabel Wayar 电源线	2.5m (8.2ft)

N5900B 235mm (9-1/4")

153

Circular Saw Gergaji Piring 圆锯



- **High power 2,000W to rip through most materials**
Kuasa tinggi 2,000W untuk pemotongan pelbagai bahan
大功率2000W可以切割大部分材料

Standard Equipment: Carbide-Tipped Saw Blade, Rip Fence (Guide Rule), Wrench 13



Continuous Rating Input Input Kuasa Berterusan 额定输入功率	2,000W
Max Cutting Capacity Kapasiti Pemotongan Maksimum 最大切割能力	90°: 85mm (3-3/8") 45°: 60mm (2-3/8") 50°: 53mm (2-1/16")
Blade Diameter Diameter Bilah 锯片直径	235mm (9-1/4")
No Load Speed (RPM) Kelajuan Tanpa Beban 回转数	4,100
Overall Length Panjang Keseluruhan 总长度	380mm (15")
Net Weight Berat Bersih 净重	6.8kg (14.8lbs)
Power Supply Cord Kabel Wayar 电源线	2.5m (8.2ft)

HS0600 260mm (10-1/4")/ 270mm (10-5/8")

153

Circular Saw Gergaji Piring 圆锯



- **Powerful 2,100W motor**
Motor berkuasa 2,100W
强力2,100W马达

Standard Equipment: TCT Saw Blade, Rip Fence (Guide Rule), Hex Wrench



Continuous Rating Input Input Kuasa Berterusan 额定输入功率	2,000W
Blade Diameter Diameter Bilah 锯片直径	260/ 270mm (10-1/4" / 10-5/8")
Max Cutting Capacity Kapasiti Pemotongan Maksimum 最大切割能力	90°: 97/ 101mm (3-13/16" / 4") 45°: 68/ 71mm (2-11/16" / 2-13/16") 50°: 61/ 63mm (2-3/8" / 2-1/2")
No Load Speed (RPM) Kelajuan Tanpa Beban 回转数	4,300
Dimensions (L x W x H) Dimensi 体积	418x273x324mm (16-1/2"x10-3/4"x12-3/4")
Net Weight Berat Bersih 净重	6.9kg (15.2lbs)
Power Supply Cord Kabel Wayar 电源线	2.5m (8.2ft)

5103N 335mm (13-1/8")

153

Circular Saw Gergaji Piring 圆锯



- **Smooth cutting at high rotational speed**
Pemotongan licin pada kelajuan putaran tinggi
在高转速下平滑切割

Standard Equipment: Wrench, Rip Fence (Guide Rule)

Continuous Rating Input Input Kuasa Berterusan 额定输入功率	1,750W
Blade Diameter Diameter Bilah 锯片直径	335mm (13-1/8")
Max Cutting Capacity Kapasiti Pemotongan Maksimum 最大切割能力	90°: 128mm (5") 45°: 91mm (3-5/8")
No Load Speed (RPM) Kelajuan Tanpa Beban 回转数	2,900
Overall Length Panjang Keseluruhan 总长度	505mm (19-7/8")
Net Weight Berat Bersih 净重	8.9kg (19.6lbs)
Power Supply Cord Kabel Wayar 电源线	5.0m (16.4ft)

Cordless
Tenggak 30.6ALED Flashlight
Lampu Suluh LED
LED照明灯Vacuum Cleaner
Penyerbuk Vakuim
吸尘器Drilling / Fastening
Cairas / Pengikat
钻孔 / 紧固Impact Drilling / Demolition
Cairas / Pencah
冲击钻孔 / 拆毁施工Cutting
Pemotong
切割Grinding / Sanding
Pengkilan / Polesan
研磨 / 打磨Sawing
Cairas
锯切Planing / Routing
Pegyalan / Tinggakan
刨削 / 雕刻Others
Lain-lain
其他Outdoor Power Equipment
Alatan Kuasa Luar
户外动力设备Makita
MAKITA

SAWING

Cordless
Tangan Keras 无绳式

LED Flashlight
Lampu Suhu LED
LED 照明灯

Vacuum Cleaner
Pembersih Vakum
吸尘器

Drilling | Fastening
Opor | Pengikat
钻孔 | 紧固

Impact Drilling | Demolition
Dobol | Penembak
冲击钻孔 | 拆除加工

Cutting
Pemotong
切割

Grinding | Sanding
Pengamiran | Habis
打磨 | 磨光

Sawing
Gergaji
锯切

Planing | Routing
Pengamiran | Tergamiran
磨光 | 磨削

Others
Lain-lain
其他

Outdoor Power Equipment
Alat-alat Tenaga Luar
园具 / 户外

Makita
Makita

5402 415mm (16-5/16")

153 W

Circular Saw

Gergaji Piring
圆锯



- **Smooth cutting at high rotational speed**
Pemotongan licin pada kelajuan putaran tinggi
在高转速下平滑切割

Standard Equipment: Combination Saw Blade, Hex Wrench, Rip Fence (Guide Rule)

Blade Diameter Diameter Bilah 锯片直径	415mm (16-5/16")
Max Cutting Capacity Kapasiti Pemotongan Maksimum 最大切割能力	90°: 157mm (6-3/16") 45°: 106mm (4-3/16")
No Load Speed (RPM) Kelajuan Tanpa Beban 回转速	2,200
Overall Length Panjang Keseluruhan 总长度	615mm (24-1/4")
Net Weight Berat Bersih 净重	12.9kg (28.4lbs)
Power Supply Cord Kabel Wayar 电源线	5.0m (16.4ft)

SP6000J 165mm (6-1/2")

303 W

Plunge Cut Circular Saw

Gergaji Piring
圆锯



- **Built-in current limiter helps prevent motor burnout**
Pengehad arus terbina dalam mencegah motor dari terbakar
电流限制器有助于防止马达烧毁

Standard Equipment: TCT Saw Blade (B-07353), Hex Wrench



Continuous Rating Input Input Kuasa Berterusan 额定输入功率	1,300W
Blade Diameter Diameter Bilah 锯片直径	165mm (6-1/2")
Max Cutting Capacity Kapasiti Pemotongan Maksimum 最大切割能力	90°: 56mm (2-3/16") 45°: 40mm (1-9/16") 48°: 38mm (1-1/2")
No Load Speed (RPM) Kelajuan Tanpa Beban 回转速	2,000 - 5,800
Dimensions (L x W x H) Dimensi 体积	341x225x250mm (13-3/8"x8-7/8"x9-7/8")
Net Weight Berat Bersih 净重	4.1kg (9lbs)
Power Supply Cord Kabel Wayar 电源线	2.5m (8.2ft)

4329

64 W

Jig Saw

Gergaji Jig
线锯机



- **Bevel cuts to 45° right or left and positive stop at 90° for solid cutting performance**
Kelajuan tinggi dan kecekapan tinggi
高速与高效率

Standard Equipment: Jig Saw Blade (B-10), Hex Wrench



Continuous Rating Input Input Kuasa Berterusan 额定输入功率	450W
Max Cutting Capacity at 90° Kapasiti Pemotongan Maksimum 最大切割能力	Wood: 65 mm (2-9/16") Steel: 6 mm (1/4")
Length of Stroke Panjang Strok 冲程长度	18 mm (11/16")
Strokes Per Minute (SPM) Kelajuan Strok 冲程速度	500 - 3,100
Dimensions (L x W x H) Dimensi 体积	223x77x197mm (8-3/4"x3"x7-3/4")
Net Weight Berat Bersih 净重	1.9kg (4.2lbs.)
Power Supply Cord Kabel Wayar 电源线	2.0m (6.6ft)

4350CT

419 W

Jig Saw

Gergaji Jig
线锯机



- **3 orbital settings plus straight cutting with a powerful 720W motor**
3 tetapan orbital serta pemotongan lurus dengan motor berkuasa 720W
强大的720W马达, 3个轨道设置与直切制

Standard Equipment: Hex Wrench, Cover Plate, Anti-Splintering Device, Jig Saw Blade Set (No. B-10, BR-13, B-22, 2pcs each)



Continuous Rating Input Input Kuasa Berterusan 额定输入功率	720W
Capacity Kapasiti 能力	Wood: 135mm (5-5/16") Steel: 10mm (3/8")
Length of Stroke Panjang Strok 冲程长度	26mm (1")
Strokes Per Minute (SPM) Kelajuan Strok 冲程速度	800 - 2,800
Dimensions (L x W x H) Dimensi 体积	236x73x207mm (9-1/4"x3"-2-7/8"x8-1/8")
Net Weight Berat Bersih 净重	2.7kg (5.8lbs)
Power Supply Cord Kabel Wayar 电源线	2.5m (8.2ft)

4351CT

419 W

Jig Saw

Gergaji Jig
线锯机



- **Bevel cuts to 45° right or left and positive stop at 90° for solid cutting performance**
Potongan serong ke 45° kanan atau kiri dan berhenti positif pada 90° untuk prestasi pemotongan pepajal
斜面切削45°左右, 90°正向切削, 切削性能稳定

Standard Equipment: Hex Wrench, Cover Plate, Anti-Splintering Device, Jig Saw Blade Set (No. B-10, BR-13, B-22, 2pcs each)



Continuous Rating Input Input Kuasa Berterusan 额定输入功率	720W
Capacity Kapasiti 能力	Wood: 135mm (5-5/16") Steel: 10mm (3/8")
Length of Stroke Panjang Strok 冲程长度	26 mm (1")
Strokes Per Minute (SPM) Kelajuan Strok 冲程速度	800 - 2,800
Dimensions (L x W x H) Dimensi 体积	271x73x187mm (10-11/16"x2-7/8"x7-3/8")
Net Weight Berat Bersih 净重	2.6kg (5.7lbs)
Power Supply Cord Kabel Wayar 电源线	2.5m (8.2ft)

Sementara stok masih ada
WHILE STOCK LAST
可取

SAWING

JV0600K

64

Jig Saw Gergaji Jig 线锯机



- **Toolless blade change system for fast blade installation and removal**
Penukaran bilah tanpa alat untuk pemasangan bilah cepat
无需工具更换刀片，可快速安装和拆卸刀片

Standard Equipment: Jig Saw Blade, Hex Wrench



Continuous Rating Input Input Kuasa Berterusan 额定输入功率	650W
Capacity Kapasiti 能力	Wood: 90mm (3-1/2") Steel: 10mm (3/8")
Length of Stroke Panjang Strok 冲程长度	23mm (7/8")
Strokes Per Minute (SPM) Kelajuan Strok 冲程速度	500 - 3,100
Dimensions (L x W x H) Dimensi 体积	236x77x199mm (9-1/4"x3"x7-7/8")
Net Weight Berat Bersih 净重	2.4kg (5.3lbs)
Power Supply Cord Kabel Wayar 电源线	2.5m (8.2ft)

4327M

64

Jig Saw Gergaji Jig 线锯机



- **High power and Lightweight**
Kuasa tinggi dan Ringan
高功率和轻量

Standard Equipment: Jig Saw Blade, Hex Wrench



Continuous Rating Input Input Kuasa Berterusan 额定输入功率	450W
Capacity Kapasiti 能力	Wood: 40mm (1-9/16") Steel: 6mm (1/4")
Length of Stroke Panjang Strok 冲程长度	18mm (11/16")
Strokes Per Minute (SPM) Kelajuan Strok 冲程速度	500 - 3,100
Dimensions (L x W x H) Dimensi 体积	224x77x197mm (8-7/8"x3"x7-3/4")
Net Weight Berat Bersih 净重	1.8kg (4.0lbs)
Power Supply Cord Kabel Wayar 电源线	2.0m (6.6ft)

4327

64

Jig Saw Gergaji Jig 线锯机



- **High power and Lightweight**
Kuasa tinggi dan Ringan
高功率和轻量

Standard Equipment: Jig Saw Blade, Hex Wrench



Continuous Rating Input Input Kuasa Berterusan 额定输入功率	450W
Capacity Kapasiti 能力	Wood: 65mm (2-9/16") Steel: 6mm (1/4")
Length of Stroke Panjang Strok 冲程长度	18mm (11/16")
Strokes Per Minute (SPM) Kelajuan Strok 冲程速度	500 - 3,100
Dimensions (L x W x H) Dimensi 体积	224x77x197mm (8-7/8"x3"x7-3/4")
Net Weight Berat Bersih 净重	1.9kg (4.2lbs)
Power Supply Cord Kabel Wayar 电源线	2.0m (6.6ft)

4300BV

51

Jig Saw Gergaji Jig 线锯机



- **Robust construction and strength to cut through a wide range of materials**
Pembinaan yang kukuh dengan kekuatan untuk memotong pelbagai bahan
坚固的结构和强度可切割各种材料

Standard Equipment: Jig saw blade set, Rip Fence (Guide Rule), Circular Guide, Hex Wrench



Continuous Rating Input Input Kuasa Berterusan 额定输入功率	390W
Capacity Kapasiti 能力	Wood: 55mm (2-1/8") Steel: 6mm (1/4")
Length of Stroke Panjang Strok 冲程长度	26mm (1")
Strokes Per Minute (SPM) Kelajuan Strok 冲程速度	0-3,100
Overall Length Panjang Keseluruhan 总长度	225mm (8-7/8")
Net Weight Berat Bersih 净重	2.5kg (5.5lbs)
Power Supply Cord Kabel Wayar 电源线	2.5m (8.2ft)

JR3050T

303

Recipro Saw Gergaji Resipro 往复锯



- **Ideal for framers, carpenters, electricians, plumbers and general construction**
Untuk framers, tukang kayu, juruelektrik, tukang paip dan pembinaan umum
木工，木匠，电工，水管工和一般建筑的理想选择

Standard Equipment: Recipro Saw Blades 3pcs (No. 21, 22, 23)



Continuous Rating Input Input Kuasa Berterusan 额定输入功率	1,010W
Length of Stroke Panjang Strok 冲程长度	28mm (1-1/8")
Strokes Per Minute (SPM) Kelajuan Strok 冲程速度	0 - 2,800
Capacity Kapasiti 能力	Pipe : 130mm (3-1/2") Wood: 255mm (10") 452mm (17-3/4")
Overall Length Panjang Keseluruhan 总长度	
Net Weight Berat Bersih 净重	3.3kg (7.3lbs)
Power Supply Cord Kabel Wayar 电源线	2.5m (8.2ft)

Cordless
Tenggakord 30.6伏

LED Flashlight
Lampu Suluh LED
LED照明灯

Vacuum Cleaner
Penyedut Vakuum
吸尘器

Drilling / Fastening
Gergaji / Pengikat
钻孔 / 紧固

Impact Drilling / Demolition
Gergaji / Pencah
冲击钻孔 / 拆除施工

Cutting
Pemotong
切割

Grinding / Sanding
Pengkilan / Pasukan
打磨 / 砂磨

Sawing
Cergas
锯切

Planing / Routing
Pegayaan / Tinggapan
刨削 / 雕刻

Others
Lain-lain
其他

Outdoor Power Equipment
Alatan Kerja Luar
园机 / 户外

Makita
MAKITA

SAWING

JR3051TK

303 

Recipro Saw Gergaji Resipro 往复锯



- **Powerful 1,200W motor for improved performance**
Meningkatkan prestasi dengan motor 1,200W
强大的1,200W电机可提高性能



Standard Equipment: Recipro Saw Blades 3pcs (No. 21, 22, 23)



Continuous Rating Input Input Kuasa Berterusan 额定输入功率	1,200W
Length of Stroke Panjang Strok 冲程长度	30mm (1-3/16")
Strokes Per Minute (SPM) Kelajuan Strok 冲程速度	0 - 3,000
Capacity Kapasiti 能力	Pipe: 130mm (5-1/8") Wood: 255mm (10")
Dimensions (L x W x H) Dimensi 体积	447x97x176mm (17-5/8"x3-13/16"x6-15/16")
Net Weight Berat Bersih 淨重	3.2 - 3.3kg (7.1 - 7.3lbs.)
Power Supply Cord Kabel Wayar 电源线	2.5m (8.2ft)

JR3061T

303 

Recipro Saw Gergaji Resipro 往复锯



- **Higher cutting efficiency & Excellent durability**
Kecekapan pemotongan yang lebih tinggi dan ketahanan yang sangat baik
更高的切割效率和卓越的耐用性



Standard Equipment: Recipro Saw Blades 3pcs (No. 21, 22, 23)



Continuous Rating Input Input Kuasa Berterusan 额定输入功率	1,250W
Length of Stroke Panjang Strok 冲程长度	32mm (1-1/4")
Strokes Per Minute (SPM) Kelajuan Strok 冲程速度	0 - 3,000
Capacity Kapasiti 能力	Pipe: 130mm (5-1/8") Wood: 255mm (10")
Dimensions (L x W x H) Dimensi 体积	487x95x177mm (19-3/16"x3-3/4"x7")
Net Weight Berat Bersih 淨重	3.8kg (8.4lbs.)
Power Supply Cord Kabel Wayar 电源线	2.5m (8.2ft)

JR3070CT

303 

Recipro Saw Gergaji Resipro 往复锯



- **Anti-Vibration Technology for 2X Less Vibration**
Mengurangkan getaran 2X dengan teknologi anti getaran
2倍减振的防振技术



Standard Equipment: Recipro Saw Blades 3pcs (No. 21, 22, 23)



Continuous Rating Input Input Kuasa Berterusan 额定输入功率	1,510W
Length of Stroke Panjang Strok 冲程长度	32mm (1-1/4")
Strokes Per Minute (SPM) Kelajuan Strok 冲程速度	0 - 2,800
Capacity Kapasiti 能力	Pipe : 130mm (5-1/8") Wood: 255mm (10")
Overall Length Panjang Keseluruhan 总长度	485mm (19-1/8")
Net Weight Berat Bersih 淨重	4.6kg (10lbs)
Power Supply Cord Kabel Wayar 电源线	2.5m (8.2ft)

SJ401

Scroll Saw Gergaji Scroll 平台式線鋸機



- **Bevel cuts up to 45° to the left and 15° to the right**
Pemotongan serong sehingga 45° ke kiri dan 15° ke kanan
斜角向左切割45°，向右切割15°



Standard Equipment: Saw blade x6, Hex Wrench, Blade Change Rod



Continuous Rating Input Input Kuasa Berterusan 额定输入功率	50W
Capacity Kapasiti 能力	Thickness of cut : 50mm (2") Throat : 406mm (16")
Length of Stroke Panjang Strok 冲程长度	18mm (11/16")
Strokes Per Minute (SPM) Kelajuan Strok 冲程速度	400-1,600
Overall Length Panjang Keseluruhan 总长度	600mm (23-5/8")
Net Weight Berat Bersih 淨重	14kg (30.87lbs)

LB1200F

Band Saw Gergaji Band 带锯



- **High/ low speed selection for excellent results in both hard and soft wood**
Pemilihan kelajuan tinggi/ rendah untuk kayu keras dan lembut
高/低速选择，切割硬木和软木



Standard Equipment: Band Saw Blades, Rip Fence, Miter Gauge, Push Stick, Nozzle, Hex Wrench, Band Saw Stand



Continuous Rating Input Input Kuasa Berterusan 额定输入功率	900W
Capacity Kapasiti 能力	Thickness of cut : 165mm (6-1/2") Throat : 305mm (12")
Blade Speed Kelajuan Bilah 锯片速度	High: (50Hz)800 (60Hz)1,000m (50 Hz)2,624 (60 Hz) 3,280ft/ min Low: (50Hz)400 (60Hz)500m (50Hz)1,312 (60Hz)1,640ft/ min
Dimensions (L x W x H) Dimensi 体积	615x775x1,600mm (24-1/4"x30-1/2"x63")
Net Weight Berat Bersih 淨重	82kg (181.2lbs)
Power Supply Cord Kabel Wayar 电源线	2.5m (8.2ft)

PLANING | ROUTERING

KP0810 82mm (3-1/4")

132

Power Planer Planer Elektrik 电刨



- **Powerful & lightweight**
Berkuasa & ringan
强力与轻量

Standard Equipment: Blade Gauge, Depth Guide, Guide Rule, Planer Blade, Socket Wrench



Continuous Rating Input Input Kuasa Berterusan 额定输入功率	850W
Planing Width Lebar Pelan 刨削宽度	82mm (3-1/4")
Planing Depth Kedalaman Pelan 刨削深度	4mm (5/32")
No Load Speed (RPM) Kelajuan Tanpa Beban 回转数	16,000
Dimensions (L x W x H) Dimensi 体积	290x168x176mm (11-3/8"x6-5/8"x6-15/16")
Net Weight Berat Bersih 净重	3.3kg (7.3lbs)
Power Supply Cord Kabel Wayar 电源线	2.5m (8.2ft)

KP0800X 82mm (3-1/4")

411

Power Planer Planer Elektrik 电刨



- **High power & lightweight**
Kuasa tinggi & ringan
高功率与轻量

Standard Equipment: Planer Blade, Blade Gauge, Guide Rule, Socket Wrench, Dust Nozzle



Continuous Rating Input Input Kuasa Berterusan 额定输入功率	620W
Planing Width Lebar Pelan 刨削宽度	82mm (3-1/4")
Planing Depth Kedalaman Pelan 刨削深度	2.5mm (3/32")
No Load Speed (RPM) Kelajuan Tanpa Beban 回转数	17,000
Dimensions (L x W x H) Dimensi 体积	285x158x158mm (11-1/4"x6-1/4"x6-1/4")
Net Weight Berat Bersih 净重	2.8kg (6.2lbs)
Power Supply Cord Kabel Wayar 电源线	2.5m (8.2ft)

N1900B 82mm (3-1/4")

51

Power Planer Planer Elektrik 电刨



- **V-groove on base for easy chamfer cutting**
V-groove pada dasar untuk pemotongan melencong mudah
底座上的V型槽，便于倒角切割

Standard Equipment: Sharpening Holder Assembly, Blade Gauge, Socket Wrench, Planer Blade, Guide Rule



Continuous Rating Input Input Kuasa Berterusan 额定输入功率	580W
Planing Width Lebar Pelan 刨削宽度	82mm (3-1/4")
Planing Depth Kedalaman Pelan 刨削深度	1mm (1/32")
No Load Speed (RPM) Kelajuan Tanpa Beban 回转数	16,000
Overall Length Panjang Keseluruhan 总长度	290mm (11-3/8")
Net Weight Berat Bersih 净重	2.8kg (6.1lbs)
Power Supply Cord Kabel Wayar 电源线	2.5m (8.2ft)

1911B 110mm (4-3/8")

106

Power Planer Planer Elektrik 电刨



- **Powerful motor in compact and lightweight body**
Motor berkuasa badan padat dan ringan
马达功能强大，体积小轻便

Standard Equipment: Sharpening Holder Assembly, Blade Gauge, Socket Wrench, Planer Blade



Continuous Rating Input Input Kuasa Berterusan 额定输入功率	840W
Planing Width Lebar Pelan 刨削宽度	110mm (4-3/8")
Planing Depth Kedalaman Pelan 刨削深度	2mm (1/16")
No Load Speed (RPM) Kelajuan Tanpa Beban 回转数	16,000
Overall Length Panjang Keseluruhan 总长度	355mm (14")
Net Weight Berat Bersih 净重	4.1kg (9.1lbs)
Power Supply Cord Kabel Wayar 电源线	5.0m (16.4ft)

1805N 155mm (6-1/8")

153

Power Planer Planer Elektrik 电刨



- **Rugged aluminum housing and easy depth settings**
Casing aluminium yang lasak dan penetapan kedalaman yang mudah
坚固的铝外壳和简单的深度设置

Standard Equipment: Sharpening Holder Assembly, Blade Gauge, Socket Wrench, Planer Blade



Continuous Rating Input Input Kuasa Berterusan 额定输入功率	1,140W
Planing Width Lebar Pelan 刨削宽度	155mm (6-1/8")
Planing Depth Kedalaman Pelan 刨削深度	2mm (1/16")
No Load Speed (RPM) Kelajuan Tanpa Beban 回转数	15,000
Overall Length Panjang Keseluruhan 总长度	445mm (17-1/2")
Net Weight Berat Bersih 净重	7.9kg (17.3lbs)
Power Supply Cord Kabel Wayar 电源线	5.0m (16.4ft)

Cordless
Tepat Aed 0.0.0.0.

LED Flashlight
Lampu Suli LED
LED080002

Vacuum Cleaner
Penbentuk Vakuu
0.0.0.0.

Drilling | Fastening
Cairat | Pengikat
0.0.0.0.

Impact Drilling | Demolition
Cairat | Penconok
0.0.0.0.

Cutting
Pemotong
0.0.0.0.

Grinding | Sanding
Pengkilan | Palsin
0.0.0.0.

Sawing
Gergaji
0.0.0.0.

Planing | Routing
Pengaliran | Tunggau
0.0.0.0.

Others
Lain-lain
0.0.0.0.

Outdoor Power Equipment
Alatan Kuasa Luar
0.0.0.0.

Makita
0.0.0.0.

PLANING | ROUTERING

2012NB 304mm (12")

153

Planer

Planer Elektrik
电刨



- **Powerful 1,650W motor for improved performance**
Motor 1,650W yang berkuasa meningkatkan prestasi
功率强劲的1,650W马达提高了性能

Standard Equipment: Socket Wrench, Hex Wrench,
Magnetic Holder x2



Continuous Rating Input Input Kuasa Berterusan 额定输入功率	1,650W
Cutting Width Lebar Pelan 刨削宽度	304mm (12")
Cutting Depth Kedalaman Pelan 刨削深度	Cutting width 0-150mm: 3mm (1/8") Cutting width 150-240mm : 1.5mm (1/16")
Feed Rate (min) Kadar Suapan 进料速度	8.5m (27.9ft)
Table Size (W x L) Saiz Meja 工作台尺寸	304 x 771mm (12" x 30-3/8")
No Load Speed (RPM) Kelajuan Tanpa Beban 回转速数	8,500
Dimensions (L x W x H) Panjang Keseluruhan 总长度	483x771x401mm (19"x30-3/8"x15-13/16")
Net Weight Berat Bersih 净重	27.1 - 27.6kg (59.7 - 60.9lbs)
Power Supply Cord Kabel Wayar 电源线	2.5m (8.2ft)

3501N

153

Groove Cutter

Pemotong alur
沟锯



- **Powerful motor, easy depth adjustment**
Motor berkuasa, pelarasan kedalaman yang mudah
强大的马达，容易调整深度

Standard Equipment: Saw Blade (A-87507), Shipping Scale,
Rip Fence (Guide Rule), Dressing Stone, Wrench x2, Screwdriver,
Cutter Blade



Continuous Rating Input Input Kuasa Berterusan 额定输入功率	1,160W
Max Cutter Blade Size Saiz Bilah Maksimum 最大锯片尺寸	Dia. x Width: 120x36mm (4-3/4"x1-3/8")
Max Cutting Depth Kedalaman Pemotongan Maksimum 最大切削深度	Cutter/ Saw: 30mm (1-1/8")/ 65 mm (2-1/2")
No Load Speed (RPM) Kelajuan Tanpa Beban 回转速数	6,500
Overall Length Panjang Keseluruhan 总长度	365mm (14-3/8")
Net Weight Berat Bersih 净重	7.2kg (15.8lbs)
Power Supply Cord Kabel Wayar 电源线	5.0m (16.4ft)

PJ7000

459

Plate Joiner

Mesin Kerja Kayu
木工接合机



- **Large and easy-to-operate cam locks for fence adjustments**
Pelarasan pagar yang mudah
简易凸轮调节

Standard Equipment: Cutter Blade, Angle Guide, Dust Bag,
Set Plate, Lock Nut Wrench



Continuous Rating Input Input Kuasa Berterusan 额定输入功率	701W
Blade Diameter Diameter Bilah 锯片直径	100mm (4")
No Load Speed (RPM) Kelajuan Tanpa Beban 回转速数	11,000
Dimensions (L x W x H) Dimensi 体积	302x139x145mm (11-7/8"x5-1/2"x5-3/4")
Net Weight Berat Bersih 净重	2.8kg (6.2lbs)
Power Supply Cord Kabel Wayar 电源线	2.5m (8.2ft)

3901

411

Plate Joiner

Mesin Kerja Kayu
木工接合机



- **Designed for making strong plate joints fast**
Direka untuk penyambungan rata
用于快速制作坚固的平板接头

Standard Equipment: Cutter Blade, Angle Guide, Dust Bag,
Set Plate, Lock Nut Wrench



Continuous Rating Input Input Kuasa Berterusan 额定输入功率	590W
Blade Diameter Diameter Bilah 锯片直径	100mm (4")
Max Cutting Depth Kedalaman Pemotongan Maksimum 最大切削深度	20mm (3/4")
No Load Speed (RPM) Kelajuan Tanpa Beban 回转速数	11,000
Overall Length Panjang Keseluruhan 总长度	307mm (12-1/16")
Net Weight Berat Bersih 净重	3.0kg (6.6lbs)
Power Supply Cord Kabel Wayar 电源线	2.5m (8.2ft)



PLANING | ROUTERING

RT0700C / X2 6mm (1/4"), 8mm (3/8")

411

Trimmer

Pemangkas
修边雕刻机



- **Powerful 710W motor for improved performance**
Motor berkuasa 710W untuk prestasi yang lebih baik
强大710W马达提高了性能

Standard Equipment:

RT0700C: Collet Cone, Trimmer Base Assembly, Straight Guide, Dust Nozzle, Wrench x2

RT0700X2: Collet Cone, Trimmer Base Assembly, Straight Guide, Dust Nozzle, Wrench x2, Side Grip, Templet Guide, Tilt Base Assembly, Plunge Base Assembly, Tool Bag



For RT0700X2 only



Continuous Rating Input Input Kuasa Berterusan 额定输入功率	710W
Collet Capacity Kapasiti Collet 夹头直径	6mm, 8mm or 1/4", 3/8"
No Load Speed (RPM) Kelajuan Tanpa Beban 回转数	10,000 - 30,000
Dimensions (L x W x H) Dimensi 体积	89x89x200mm (3-1/2"x3-1/2"x7-7/8")
Net Weight Berat Bersih 净重	1.8 - 2.7kg (3.9 - 6.0lbs)
Power Supply Cord Kabel Wayar 电源线	2.5m (8.2ft.)

3709 6mm (1/4")

411

Trimmer

Pemangkas
修边雕刻机

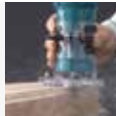

- **530W motor for smooth trimming**
530W motor untuk pemangkasan yang licin
530W马达提供平滑的修剪

Standard Equipment: Collet Cone, Trimmer Guide, Straight Guide Assembly, Templet Guide, Straight Bit, Chip Deflector, Wrench x2



Continuous Rating Input Input Kuasa Berterusan 额定输入功率	530W
Collet Capacity Kapasiti Collet 夹头直径	6mm or 1/4"
No Load Speed (RPM) Kelajuan Tanpa Beban 回转数	30,000
Dimensions (L x W x H) Dimensi 体积	82x90x199mm (3-1/2"x3-1/2"x7-7/8")
Net Weight Berat Bersih 净重	1.5kg (3.3lbs)
Power Supply Cord Kabel Wayar 电源线	2.5m (8.2ft.)

RP0900 6mm (1/4"), 8mm (3/8")

106

Router (Plunge type)

Pemangkas
雕刻机



- **Oversized ball bearing construction for longer tool life**
Konstruksi gelas bebola untuk memanjangkan hayat alat
超大滚珠轴承结构，延长工具寿命

Standard Equipment: Straight Guide, Collet Cone, Wrenches x2



Continuous Rating Input Input Kuasa Berterusan 额定输入功率	900W
Collet Capacity Kapasiti Collet 夹头直径	6mm, 8mm or 1/4", 3/8"
Plunge Capacity Kapasiti Plunge 能力	0 - 35mm (0 - 1-3/8")
No Load Speed (RPM) Kelajuan Tanpa Beban 回转数	27,000
Dimensions (L x W x H) Dimensi 体积	110x256x217mm (4-5/16"x10-3/32"x8-17/32")
Net Weight Berat Bersih 净重	2.7kg (6lbs)
Power Supply Cord Kabel Wayar 电源线	2.5m (8.2ft.)

RP2303FC 12mm (1/2")

203

Router

Pemangkas
雕刻机



- **Combines power and precision for the most demanding routing applications**
Menggabungkan kuasa dan ketepatan untuk aplikasi yang paling mencabar
为最苛刻的应用提供强大的功能和精准度

Standard Equipment: Straight Guide, Collet Sleeve, Collet Cone, Wrench, Straight Bit (D-07901)



Continuous Rating Input Input Kuasa Berterusan 额定输入功率	2,100W
Collet Capacity Kapasiti Collet 夹头直径	12mm (1/2")
Plunge Capacity Kapasiti Plunge 能力	0 - 70mm (0 - 2-3/4")
No Load Speed (RPM) Kelajuan Tanpa Beban 回转数	9,000 - 23,000
Dimensions (L x W x H) Dimensi 体积	155x294x327mm (6-1/8"x11-5/8"x12-7/8")
Net Weight Berat Bersih 净重	6.2kg (13.7lbs.)
Power Supply Cord Kabel Wayar 电源线	4.0m (13.1ft)

RP2301FC 12mm (1/2")

203

Router (Plunge type)

Pemangkas
雕刻机



- **Powerful 2,100W motor for the most demanding applications**
Motor 2,100W berkuasa untuk aplikasi yang paling mencabar
功能强大2,100W马达，适用于要求苛刻的应用

Standard Equipment: Straight Guide, Collet Cone, Wrench, Screw M6x135, Straight Bit 1/2" (D-07901)



Continuous Rating Input Input Kuasa Berterusan 额定输入功率	2,100W
Collet Capacity Kapasiti Collet 夹头直径	12mm or 1/2"
Plunge Capacity Kapasiti Plunge 能力	0 - 70mm (0 - 2-3/4")
No Load Speed (RPM) Kelajuan Tanpa Beban 回转数	9,000 - 22,000
Dimensions (L x W x H) Dimensi 体积	155x294x312mm (6-1/8"x11-5/8"x12-1/4")
Net Weight Berat Bersih 净重	6.1kg (13.5lbs)
Power Supply Cord Kabel Wayar 电源线	4.0m (13.1ft.)

Cordless
Tetapan Aord 10.8VLED Flashlight
Lampu Suka LED
LED 0.8W 10.8VVacuum Cleaner
Penembuh Vakuam
吸尘器Drilling / Fastening
Cairan / Pengikat
钻孔 / 紧固Impact Drilling / Demolition
Cairan / Pemecah
打桩机 / 拆墙机Cutting
Pemotong
切割Grinding / Sanding
Pengkilan / Pasukan
打磨 / 砂磨Sawing
Gergaji
锯切Planing / Routing
Pangkas / Tunggai
刨削 / 通削Others
Lain-lain
其他Outdoor Power Equipment
Alatan Kuasa Luar
户外动力设备Makita
MAKITA

PLANING | ROUTERING

RP1803 12mm (1/2")

203 

Router Pemangkas 雕刻机

- Deep 0 - 70mm (0" - 2-3/4") plunge depth capacity for easy penetration into work piece



Standard Equipment: Straight Guide, Collet Sleeve, Collet Cone, Wrench, Template Guide



Continuous Rating Input Input Kuasa Berterusan 额定输入功率	1,650W
Collet Capacity Kapasiti Collet 夹头直径	12mm (1/2")
Plunge Capacity Kapasiti Plunge 能力	0 - 70mm (0 - 2-3/4")
No Load Speed (RPM) Kelajuan Tanpa Beban 回转数	22,000
Dimensions (L x W x H) Dimensi 体积	155x294x312mm (6-1/8"x11-5/8"x12-1/4")
Net Weight Berat Bersih 净重	6.2kg (13.7lbs.)
Power Supply Cord Kabel Wayar 电源线	2.5m (8.2ft)

RP1801 12mm (1/2")

203 

Router (Plunge type) Pemangkas 雕刻机



- Electric brake for increased operator safety
Brake elektrik untuk pengguna keselamatan
电子自动刹车



Standard Equipment: Straight Guide, Collet Cone, Wrench, Screw M6x135, Template Guide



Continuous Rating Input Input Kuasa Berterusan 额定输入功率	1,650W
Collet Capacity Kapasiti Collet 夹头直径	12mm or 1/2"
Plunge Capacity Kapasiti Plunge 能力	0 - 70mm (0 - 2-3/4")
Base Dia. Diameter Pangkalan 底座直径	170mm (6-11/16")
No Load Speed (RPM) Kelajuan Tanpa Beban 回转数	22,000
Dimensions (L x W x H) Dimensi 体积	155x294x312mm (6-1/8"x11-5/8"x12-1/4")
Net Weight Berat Bersih 净重	6kg (13.2lbs)
Power Supply Cord Kabel Wayar 电源线	4.0m (13.1ft.)

3612BR 12mm (1/2")

153 

Router (Plunge type) Pemangkas 雕刻机

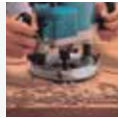

- Conveniently located plunge lock lever for efficient operation
Pelarasan tuil yang mudah untuk operasi yang cekap
便利的插入式锁定杆可实现高效操作



Standard Equipment: Straight Guide, Template Guide, Trimmer Guide, Guide Holder, Collet Sleeve (6mm or 1/4"), Collet Sleeve (8mm or 3/8"), Straight Bit (Carbide-Tipped) D-07901, Wrench



Continuous Rating Input Input Kuasa Berterusan 额定输入功率	1,600W
Collet Capacity Kapasiti Collet 夹头直径	12mm or 1/2"
Plunge Capacity Kapasiti Plunge 能力	0 - 65mm (0 - 2-9/16")
No Load Speed (RPM) Kelajuan Tanpa Beban 回转数	23,000
Dimensions (L x W x H) Dimensi 体积	160x276x287mm (6-5/16"x10-7/8"x11-5/16")
Net Weight Berat Bersih 净重	5.5kg (12.1lbs)
Power Supply Cord Kabel Wayar 电源线	2.5m (8.2ft.)

3600H 12mm (1/2")

153 

Router Pemangkas 雕刻机



- D-handle design with locking trigger switch for comfort during continuous operation
Pemegang-D dengan suis pencetus berlock untuk keselesaan semasa operasi berterusan
带锁定扳机开关的D型手柄设计可确保连续操作时的舒适性



Standard Equipment: Trimmer Guide, Straight Guide Assembly, Template Guide, Collet Sleeve (6mm or 1/4"), Collet Sleeve (8mm or 3/8"), Wrench, Straight Bit (Carbide-Tipped) D-07901

4403 6mm (1/4")

411 

Sash Router Pemangkas Sash 窗扇雕刻机



- Large transparent chip guard for operator's safety
Pengawal cip telus yang besar untuk keselamatan pengguna
大型透明芯片防护罩保证操作者的安全



Standard Equipment: Collet Cone (6mm or 1/4"), Drill Point Sash Router Bit (D-16972), Angle Gauge, Wrench x2, Oil Supply



Continuous rating input Input Kuasa Berterusan 额定输入功率	530W
Capacity Kapasiti 能力	Collet: 6mm or 1/4"
Max Width of Work Lebar Kerja Maksimum 最大工作宽度	123mm (4-7/8")
Max Width of Work (45°) Lebar Kerja Maksimum 最大工作宽度	77mm (3")
Max Height of Work Ketinggian Kerja Maksimum 最大工作高度	185mm (7-1/4")
No Load Speed (RPM) Kelajuan Tanpa Beban 回转数	30,000
Dimensions (L x W x H) Dimensi 体积	327x350x355mm (12-7/8"x13-13/16"x14")
Net Weight Berat Bersih 净重	16kg (35.3lbs)
Power Supply Cord Kabel Wayar 电源线	2.5m (8.2ft)

OTHERS

AF506

Pneumatic Brad Nailer
Penembak Paku Brad Pneumatik
气钉枪



- **Lightweight for reduced operator fatigue**
Ringan untuk mengurangi kelelahan pengguna
轻量不易引起疲劳

Standard Equipment: Safety Goggles, Nose Adapter, Oil



Capacity Kapasiti 能力	Length: 15 - 50mm (5/8" - 2")
Operating Pressure Tekanan Beroperasi 使用气压	Gauge: 18Ga
Magazine Capacity Bilangan Staples 装订个数	100
Compressed Air Udara Mampat 压缩空气	Driver stroke: 85.5mm (3-3/8")
Dimensions (L x W x H) Dimensi 体积	Cylinder bore diameter: 28mm (1-1/8")
Net Weight Berat Bersih 净重	250x70x256mm (9-7/8"x2-3/4"x10-1/8")
	1.3kg (2.9lbs.)

Accessories (optional)			
Description	Size	Pcs/ Box	Part No.
Brad Nail 15mm (5/8")	F15	5,000	B-04307
Brad Nail 20mm (3/4")	F20	5,000	B-04313
Brad Nail 25mm (1")	F25	5,000	B-04329
Brad Nail 30mm (1-3/16")	F30	5,000	B-04335
Brad Nail 35mm (1-3/8")	F35	5,000	B-04357

AF353

Pneumatic Pin Nailer
Mesin Pemaku Pneumatik
气钉枪



- **Lightweight for reduced operator fatigue**
Ringan untuk mengurangi kelelahan pengguna
轻量不易引起疲劳

Standard Equipment: Safety Goggles, Nose Adapter, Hex Wrench, Oil



Capacity Kapasiti 能力	Length: 15 - 35mm (5/8" - 1-3/8")
Operating Pressure Tekanan Beroperasi 使用气压	Gauge: 23Ga
Magazine Capacity Bilangan Staples 装订个数	130
Dimensions (L x W x H) Dimensi 体积	208x66x191mm (8-3/16"x2-5/8"x7-1/2")
Net Weight Berat Bersih 净重	0.9kg (2lbs.)

Accessories (optional)			
Description	Size	Pcs/ Box	Part No.
Pin Nail 18mm (11/16")	P18	10,000	F-31825
Pin Nail 25mm (1")	P25	10,000	F-31838
Pin Nail 30mm (1-3/16")	P30	10,000	F-31841
Pin Nail 35mm (1-3/8")	P35	10,000	F-31854

*Order upon request

AF601

Pneumatic Finish Nailer
Mesin Pemaku Pneumatik
气钉枪



- **Lightweight for reduced operator fatigue**
Ringan untuk mengurangi kelelahan pengguna
轻量不易引起疲劳

Standard Equipment: Safety Goggles, Nose Adapter, Oil



Capacity Kapasiti 能力	Length: 25 - 64mm (1" - 2-1/2")
Operating Pressure Tekanan Beroperasi 使用气压	Gauge: 16Ga
Magazine Capacity Bilangan Staples 装订个数	100
Dimensions (L x W x H) Dimensi 体积	304x95x297mm (12"x3-3/4"x11-3/4")
Net Weight Berat Bersih 净重	1.7kg (3.8lbs.)

Accessories (optional)					
Description	Pcs/ Box	Part No.	Description	Pcs/ Box	Part No.
Finish Nail 25mm (1")	2,000	F-33922	Finish Nail 45mm (1-3/4")	2,000	F-33980
Finish Nail 30mm (1-3/16")	2,000	F-33935	Finish Nail 50mm (2")	2,000	F-33993
Finish Nail 32mm (1-1/4")	2,000	F-33948	Finish Nail 57mm (1-1/4")	2,000	F-34001
Finish Nail 35mm (1-3/8")	2,000	F-33951	Finish Nail 60mm (2-3/8")	2,000	F-34014
Finish Nail 38mm (1-1/2")	2,000	F-33964	Finish Nail 64mm (2-1/2")	2,000	F-34027
Finish Nail 40mm (1-9/16")	2,000	F-33977			

*Order upon request

AF635

Pneumatic Finish Nailer
Mesin Pemaku Pneumatik
气钉枪



- **Lightweight for reduced operator fatigue**
Ringan untuk mengurangi kelelahan pengguna
轻量不易引起疲劳

Standard Equipment: Safety Goggles, Nose Adapter, Oil



Capacity Kapasiti 能力	Length: 32 - 64mm (1-1/4" - 2-1/2")
Operating Pressure Tekanan Beroperasi 使用气压	Gauge: 15Ga
Magazine Capacity Bilangan Staples 装订个数	100
Dimensions (L x W x H) Dimensi 体积	339x100x309mm (13-3/8"x3-15/16"x12-1/8")
Net Weight Berat Bersih 净重	1.8kg (4lbs.)

Accessories (optional)		
Description	Pcs/ Box	Part No.
Finish Nail 32mm (1-1/4")	4,000	F-31960
Finish Nail 38mm (1-1/2")	4,000	F-31973
Finish Nail 45mm (1-3/4")	4,000	F-31986
Finish Nail 50mm (2")	4,000	F-31999
Finish Nail 57mm (1-1/4")	4,000	F-32007
Finish Nail 64mm (2-1/2")	4,000	F-32010

*Order upon request

AT638A

Narrow Crown Stapler
Mesin Pemaku Pneumatik
气钉枪



- **Lightweight for reduced operator fatigue**
Ringan untuk mengurangi kelelahan pengguna
轻量不易引起疲劳

Standard Equipment: Safety Goggles, Nose Adapter, Oil

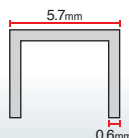

Capacity Kapasiti 能力	Length: 13 - 38mm (1/2" - 1-1/2")
	Gauge: 18Ga
	Width: 5.7mm
Operating Pressure Tekanan Beroperasi 使用气压	0.49 - 0.83MPa (70 - 120PSI)
Magazine Capacity Bilangan Staples 装订个数	100
Dimensions (L x W x H) Dimensi 体积	230x75x251mm (9"x2-15/16"x9-7/8")
Net Weight Berat Bersih 净重	1.2kg (2.7lbs.)

Cordless
Tanpa Kabel 无线

LED Flashlight
Lampu Saku LED
LED手电筒

Vacuum Cleaner
Penyedot Vakum
吸尘器

Drilling / Fastening
Gantol / Pengikat
钻头 / 紧固件

Impact Drilling / Demolition
Gantol / Pemukul
冲击钻头 / 破拆工具

Cutting / Sanding
Pemotong / Gores
切割 / 打磨

Grinding / Sanding
Pengkilan / Pemoles
打磨 / 抛光

Sawing
Gergaji
锯切

Planing / Routing
Penyetan / Tumpang
刨削 / 压边

Others
Lain-lain
其他

Outdoor Power Equipment
Alatan Kuat Luar
园林工具



OTHERS

Heat Gun

Accessories (Optional)



-  **Glass protection nozzle**
Part No. PR00000028
-  **Wide-slot nozzle**
Part No. PR00000029
-  **Reflector nozzle**
Part No. PR00000030
-  **Reduction nozzle 20**
Part No. PR00000031
-  **Pressure roller**
Part No. PR00000035
-  **Scraper**
Part No. PR00000040
-  **Overlap welding nozzle**
Part No. PR00000032
-  **Solder sleeves reflector**
Part No. PR00000033
-  **Welding nozzle**
Part No. PR00000034
-  **Speed welding nozzle**
Part No. PR00000039
-  **Welding rods**
(ABS) Part No. PR00000036
(HDPE) Part No. PR00000037
(PP) Part No. PR00000038
-  **Scraper set**
Part No. PR00000041
-  **Scraper**
Part No. PR00000042

HG6530VK

Heat Gun
Pistol Udara Panas
热风枪



- **3-speed blower settings for greater versatility**
Kawalan kelajuan 3 tahap untuk pelbagai aplikasi
3速度控制适合多种用途



Standard Equipment: Glass Protection Nozzle, Reflector Nozzle, Reduction Nozzle, Wide Slot Nozzle



Air Temperature (°C) Suhu Udara 气温	50 - 650
Air Flow Aliran Udara 空气流量	Stage 1: 500 L/min Stage 2: 280 L/min Stage 3: 550 L/min
Dimensions (L x W x H) Dimensi 体积	257x85x206mm (10-1/8"x3-3/8"x8-1/8")
Net Weight Berat Bersih 净重	0.72kg (1.6lbs.)
Power Supply Cord Kabel Wayar 电源线	2.0m (6.6ft)

HG6031VK

Heat Gun
Pistol Udara Panas
热风枪



- **9-temperature settings (50 - 600°C) for a variety of applications**
9 tetapan suhu (50 - 600°C) sesuai untuk pelbagai aplikasi
9个温度设定 (50 - 600°C) 适合于各种用途



Standard Equipment: Glass Protection Nozzle, Reflector Nozzle, Reduction Nozzle, Wide Slot Nozzle



Continuous Rating Input Input Kuasa Berterusan 额定输入功率	1,800W
Air Temperature (°C) / Flow (L/min) Suhu Udara 气温	Switch 1: 50 - 400 / 250 Switch 2: 100 - 600 / 500
Dimensions (L x W x H) Dimensi 体积	257x85x206mm (10-1/8"x3-3/8"x8-1/8")
Net Weight Berat Bersih 净重	0.67kg (1.5lbs)
Power Supply Cord Kabel Wayar 电源线	2.0m (6.6ft)

HG5030K

Heat Gun
Pistol Udara Panas
热风枪



- **2 temperature settings (350 and 500°C)**
2 tetapan suhu (350 dan 500°C)
2个温度设定 (350和500°C)



Standard Equipment: Glass Protection Nozzle, Reflector Nozzle, Reduction Nozzle, Wide Slot Nozzle



Continuous Rating Input Input Kuasa Berterusan 额定输入功率	1,600W
Air Temperature (°C) / Flow (L/min) Suhu Udara 气温	Switch 1: 350 / 300 Switch 2: 500 / 500
Dimensions (L x W x H) Dimensi 体积	233x80x208mm (9-1/8"x3-1/8"x8-3/16")
Net Weight Berat Bersih 净重	0.56kg (1.2lbs)
Power Supply Cord Kabel Wayar 电源线	2.0m (6.6ft)

SK104Z

Cross Line Laser
Laser Garis Salib
十字线激光



- **Accuracy +/- 3mm @ 10m**
Ketepatan +/- 3mm @ 10m
精确度 +/- 3mm @ 10m



Standard Equipment: Wall Mount Bracket, Target Plate, AA Battery, Pouch with strap

Measuring Range Jarak Mengukur 测量范围	Up to 15m w/ detector up to: 60m
Leveling Accuracy Menunjukkan Ketepatan 指示精确度	±3mm/ 10m
Self-leveling Range Julat Indikasi Menegak 垂直指示范围	4+-1°
Laser Fan Angle Sudut Peminat Laser 激光扇角	Horizontal: 180° Vertical: 180°
Number of Laser Bilangan Garisan Laser 激光线数量	points: 4 lines: 2 Laser class 2: 635nm
Laser Type Jenis Laser 激光类型	
Tripod Thread Tripod 脚架	1/4"
Protection Class Tahap Perlindungan 保护等级	IP54
Net Weight Berat Bersih 净重	0.53kg (1.17lbs)

Cordless
Turret Head 炮台式

LED Flashlight
Lampu Flash LED
LED 照明灯

Vacuum Cleaner
Pembersih Vakuum
吸尘器

Drilling / Fastening
Ganubi / Pengikat
钻孔 / 紧固

Impact Drilling / Demolition
Ganubi / Penembak
冲击钻孔 / 拆除加工

Cutting
Pemotong
切割

Grinding / Sanding
Pengamir / Pasir
打磨 / 砂磨

Sawing
Gergaji
锯切

Planing / Routing
Penyalam / Tanggapan
刨削 / 雕刻

Others
Lain-lain
其他

Outdoor Power Equipment
Alatan Kerja Luar
园具-户外



OTHERS

LD030P

Laser Distance Measure
Langkah Jarak Laser
激光测距



- **Measuring distance operating range up to 30m**
Mengukur jarak operasi jarak sehingga 30m
测量距离可达30米

Measuring Range Jarak Mengukur 测量范围	0.2-30m
Typical Measuring Tolerance Toleransi Mengukur Biasa 典型的测量公差	±2.0mm/ 10m
Max Measuring Tolerance Toleransi Mengukur Maksimum 最大测量公差	±3.0mm/ 10m
Diameter of Laser Point Diameter Titik Laser 激光点的直径	6mm/ 10m
Laser Type Jenis Laser 激光类型	Laser class 2: 635nm
Dimensions (H x D x W) Dimensi 体积	117x53x25mm (4.5"x2.14"x1")
Net Weight Berat Bersih 净重	0.1kg (0.22lbs)

LD050P

Laser Distance Measure
Langkah Jarak Laser
激光测距



- **Measuring distance operating range up to 50m**
Mengukur jarak operasi jarak sehingga 50m
测量距离可达50米

Measuring Range Jarak mengukur 测量范围	0.05-50m
Power Supply Bekalan Kuasa 电源	Cell battery : AAA 1.5V x 2pcs
Net Weight Berat Bersih 净重	0.1kg (0.22lbs)

Standard Equipment: Pouch

LD080P / LD080PI

Laser Distance Measure
Langkah Jarak Laser
激光测距



LD080P

- **Measuring distance operating range up to 80m**
Mengukur jarak operasi jarak sehingga 80m
测量距离可达80米

Measuring Range Jarak mengukur 测量范围	0.05-80m
Power Supply Bekalan Kuasa 电源	Cell battery : AAA 1.5V x 2pcs
Net Weight Berat Bersih 净重	0.14kg (0.31lbs)

Standard Equipment: Carrying Strap, Pouch

UB1103

Blower
Mesin Blower
吹风机



- **Two tools in one; quickly converts to a vacuum for added versatility**
Alat 2 dalam 1, vakum dan blower untuk fleksibiliti tambahan
一机2用, 集尘与吹风

303 W

Continuous Rating Input Input Kuasa Berterusan 额定输入功率	600W
Max Air Volume Isipadu Angin Maksimum 最大风量	0 - 4.1m ³ /min
Max Air Velocity Velositi Angin Maksimum 最大风速	0 - 91m/s
Air Pressure Tekanan Udara 气压	0 - 5.7kPa
No Load Speed (RPM) Kelajuan Tanpa Beban 回转数	0 - 16,000
Dimensions (L x W x H) Dimensi 体积	479x185x178mm (18-7/8"x7-1/4"x7")
Net Weight Berat Bersih 净重	1.9 - 2.2kg (4.3 - 4.8lbs)
Power Supply Cord Kabel Wayar 电源线	2.5m (8.2ft.)

Standard Equipment: Nozzle, Dust Bag



HS100

Hammer Tacker
Alat Manual Memaku Mesin
手动工具敲钉机

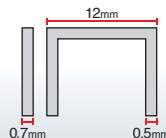

Capacity Kapasiti 能力	Width: 12mm Length: 6 - 10mm
Magazine Capacity Bilangan Staples 装钉个数	144
Dimensions (L x W x H) Dimensi 体积	281mm
Net Weight Berat Bersih 净重	0.5kg

Accessories (optional)

Description	Length	Pcs/ Box	Part No.
Staple CT10M	10mm (3/8")	20,160	F-81772

*Order upon request

Cordless
Tanpa Kord 无线式

LED Flashlight
Lampu Suluh LED
LED照明灯

Vacuum Cleaner
Penembuh Vakum
吸尘器

Drilling / Fastening
Cairul / Penambat
钻孔 / 紧固

Impact Drilling / Demolition
Cairul / Penambat
石工钻孔 / 拆毁动工

Cutting
Pemotong
切割

Grinding / Sanding
Pengisar / Pencil
研磨 / 砂磨

Sawing
Gergaji
锯切

Planing / Routing
Penyoakan / Tunggam
刨削 / 磨削

Others
Lain-lain
其他

Outdoor Power Equipment
Alatan Kuasa Luar
园林户外



OUTDOOR POWER EQUIPMENT

Cordless
Tanpa Kabel Listrik

LED Flashlight
Lampu Senter LED
LED 燈前照灯

Vacuum Cleaner
Pembersih Vakum
吸尘器

Drilling / Fastening
Dremel / Pengikat
钻头 / 螺丝

Impact Drilling / Demolition
Dremel / Pemecah
钻头/ 冲击加工

Cutting
Pemotong
切割机

Grinding / Sanding
Pengamir / Habisir
打磨 / 打磨

Sawing
Dagang
锯切

Planting / Routing
Penyulam / Rangkaian
插植 / 雕刻

Others
Lain-lain
其他

Outdoor Power Equipment
Alat-alat Kerja Luar
器械/ 户外

Makita
Makita

UC3551A 350mm (14") | UC4051A 400mm (16") 153

Electric Chain Saw
Gergaji Rantai
电链锯



- **Fast and efficient cutting**
Pemotongan cepat dan cekap
快速高效的切割

Standard Equipment: Saw Chain, Guide Bar, Guide Bar Cover, Hook Complete



Continuous Rating Input Input Kuasa Berterusan 额定输入功率	1,800W
Chain Speed per Minute Kelajuan Rantai 链条速度	870m (2,900ft)
Guide Bar Length Panjang Bar Panduan 导板长度	350mm (14") UC3551A 400mm (16") UC4051A
Saw Chain Rantai 链条	Pitch : 9.5mm (3/8") Gauge: 1.3mm (0.050")
Dimensions (L x W x H) Dimensi 体积	505x200x220mm (19-7/8"x7-7/8"x8-5/8")
Net Weight Berat Bersih 净重	5.5kg (12.1lbs) UC3551A 5.6kg (12.3lbs) UC4051A
Power Supply Cord Kabel Wayar 电源线	0.3m (0.98ft)

UC3541A 350mm (14") | UC4041A 400mm (16") 132

Electric Chain Saw
Gergaji Rantai
电链锯



- **Zero emissions and reduced maintenance**
Tanpa perlepasan asap & penyelenggaraan rendah
无排气及降低保养少维护

Standard Equipment: Saw Chain, Guide Bar, Guide Bar Cover, Hook Complete



Continuous Rating Input Input Kuasa Berterusan 额定输入功率	1,800W
Chain Speed per Minute Kelajuan Rantai 链条速度	870m (2,900ft)
Guide Bar Length Panjang Bar Panduan 导板长度	350mm (14") UC3541A 400mm (16") UC4041A
Saw Chain Rantai 链条	Pitch : 9.5mm (3/8") Gauge: 1.1mm (0.043")/ 1.3mm (0.050")
Dimensions (L x W x H) Dimensi 体积	455x245x200mm (17-7/8"x9-5/8"x7-7/8")
Net Weight Berat Bersih 净重	4.7 - 4.9kg (10.4 - 10.6lbs)
Power Supply Cord Kabel Wayar 电源线	0.3m (0.98ft)

5016B 405mm (16") 153

Electric Chain Saw
Gergaji Rantai
电链锯



- **Compact and lightweight design**
Reka bentuk padat dan ringan
小巧轻便的设计

Standard Equipment: Saw Chain, Oil supply 100ml, Socket Wrench, File, Screwdriver



WHILE STOCK LAST
Sementara stok masih ada
平價快購

Continuous Rating Input Input Kuasa Berterusan 额定输入功率	1,300W
Chain Speed per Minute Kelajuan Rantai 链条速度	400m (1,310ft)
Guide Bar Length Panjang Bar Panduan 导板长度	405mm (16")
Saw Chain Rantai 链条	Pitch : 9.5mm (3/8") Gauge: 1.3" or 0.050"
Overall Length Panjang Keseluruhan 总长度	750mm (29-1/2")
Net Weight Berat Bersih 净重	5.8kg (12.7lbs)
Power Supply Cord Kabel Wayar 电源线	5.0m (16.4ft)

UH7580X 750mm (29-1/2") 419

Electric Hedge Trimmer
Pemangkas Tanaman Pagar
电篱笆修剪机



- **Powerful 670W motor**
Motor berkuasa 670W
强劲的670W电机

Standard Equipment: Blade Cover, Hook complete, Belt Hook



Continuous Rating Input Input Kuasa Berterusan 额定输入功率	670W
Blade Length Panjang Bilah 锯片长度	750mm (29-1/2")
Strokes Per Minute (SPM) Kelajuan Strok 冲程速度	3,000
Tooth Spacing Selang Gigi 牙齿间隔	18mm (11/16")
Net Weight Keberatan 净重	4.4kg (9.7lbs.)
Power Supply Cord Kabel Wayar 电源线	0.3m (0.98ft)



OUTDOOR POWER EQUIPMENT



ELM4121 410mm (16-1/8")

Electric Lawn Mower Mesin Pemotong Rumput 电手推割草机



- **Robust steel cutting deck for increased durability**
Dek keluli memotong untuk meningkatkan ketahanan
钢制切割台提高其耐用性

Standard Equipment: Blade, Wrench, Mulch Plug



Continuous Rating Input Input Kuasa Berterusan 额定输入功率	1,600W
Hole Diameter Diameter Lubang 孔直径	8mm (5/16")
Cutting Width Lebar Keratan 切割宽度	410mm (16-1/8")
Cutting Height Ketinggian Pemotongan 切割高度	20 - 75mm (13/16" - 2-15/16")
No Load Speed (RPM) Kelajuan Tanpa Beban 回转数	3,400
Recommended mowing area up to Julat Memotong yang Disyorkan 推荐的割草范围	600m ²
Grass Box Capacity Kapasiti Kotak Rumput 草箱容量	50L
Wheel Size Saiz Roda 轮片尺寸	Front / Rear: 156 / 200mm (6-1/8 / 7-7/8")
Dimensions (L x W x H) Dimensi 体积	1,465x530x905-1,135mm (57-3/4"x20-7/8"x35-5/8" - 44-3/4")
Net Weight Berat Bersih 净重	17.5 - 19.1kg (38.6 - 42.1lbs.)

ELM3720 370mm (14-1/2")

Electric Lawn Mower Mesin Pemotong Rumput 电手推割草机



- **Stays upright for easy maintenance and cleaning**
Penyelenggaraan dan pembersihan lebih mudah
简单维护和清洁

Standard Equipment: Blade, Wrench



Continuous Rating Input Input Kuasa Berterusan 额定输入功率	1,400W
Hole Diameter Diameter Lubang 孔直径	8mm (5/16")
Cutting Width Lebar Keratan 切割宽度	370mm (14-1/2")
Cutting Height Ketinggian Pemotongan 切割高度	20 - 55mm (13/16" - 2-3/16")
No Load Speed (RPM) Kelajuan Tanpa Beban 回转数	3,400
Recommended mowing area up to Julat Memotong yang Disyorkan 推荐的割草范围	500m ²
Grass Box Capacity Kapasiti Kotak Rumput 草箱容量	40L
Wheel Size Saiz Roda 轮片尺寸	Front / Rear: 139 / 178mm (5-1/2 / 7")
Dimensions (L x W x H) Dimensi 体积	1,330x415x890-1,120mm (52-3/8"x16-3/8"x35" - 44")
Net Weight Berat Bersih 净重	11.6kg (25.6lbs.)

ELM3320 330mm (13")

Electric Lawn Mower Mesin Pemotong Rumput 电手推割草机

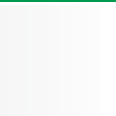

- **Stays upright for easy maintenance and cleaning**
Penyelenggaraan dan pembersihan lebih mudah
简单维护和清洁

Standard Equipment: Blade, Wrench



Continuous Rating Input Input Kuasa Berterusan 额定输入功率	1,200W
Hole Diameter Diameter Lubang 孔直径	8mm (5/16")
Cutting Width Lebar Keratan 切割宽度	330mm (13")
Cutting Height Ketinggian Pemotongan 切割高度	20 - 55mm (13/16" - 2-3/16")
No Load Speed (RPM) Kelajuan Tanpa Beban 回转数	3,400
Recommended mowing area up to Julat Memotong yang Disyorkan 推荐的割草范围	400m ²
Grass Box Capacity Kapasiti Kotak Rumput 草箱容量	30L
Wheel Size Saiz Roda 轮片尺寸	Front / Rear: 139 / 178mm (5-1/2 / 7")
Dimensions (L x W x H) Dimensi 体积	1,230x380x870-1,110mm (48-1/2"x15"x34-1/4" - 43-3/4")
Net Weight Berat Bersih 净重	10.2kg (22.5lbs.)

Cordless
Terdapat 60V Li-Ion

LED Flashlight
Lampu Suhu LED
LED 照明灯

Vacuum Cleaner
Pembersih Vakuam
吸尘器

Drilling / Fastening
Cairul / Pengikat
钻孔 / 紧固

Impact Drilling / Demolition
Cairul / Pemusnah
冲击钻孔 / 拆毁工具

Cutting
Pemotongan
切割

Grinding / Sanding
Pengiraan / Polesan
打磨 / 研磨

Sawing
Cairul
锯切

Planing / Routing
Pegayaan / Tanggapan
刨削 / 雕刻

Others
Lain-lain
其他

Outdoor Power Equipment
Alatan Kuasa Luar
园林工具

Makita
工具

OUTDOOR POWER EQUIPMENT

Cordless
Tali Kosok Baterai

LED Flashlight
Lampu Senter LED
LED 9000197

Vacuum Cleaner
Pembersih Vakum
MS-201

Drilling | Fastening
Gergaji | Pengikat
M12 | M16

Impact Drilling | Demolition
Dobok | Pemecah
D1.2M12 | 1.2M16

Cutting
Pemotong
0101

Grinding | Sanding
Pengamir | Habis
0101 | 0102

Sawing
Gergaji
0101

Planing | Routing
Pengaliran | Rute
0101 | 0102

Others
Lain-lain
0101

Outdoor Power Equipment
Alat-alat Tenaga Listrik
0101



Powerful Washing

VARIOUS OPTIONS
Pelbagai pilihan
各种选择

- Trigger gun set
Part No. 197842-2
- Variable nozzle set
Part No. 197822-8
- Cyclone jet nozzle set
Part No. 197824-4
- Cyclone guard set
Part No. 197864-2
- Variospray lance set
Part No. 197876-5
- Under body spray lance set
Part No. 198909-9
- Extension pipe set
Part No. 197870-7
- Rotating brush set
Part No. 197831-7
- Wash brush set
Part No. 197828-6
- Foam nozzle set
Part No. 197886-2
- Pipe cleaning hose
Part No. 197837-5
- Self-suction hose set
Part No. 197873-1



OUTDOOR POWER EQUIPMENT



HW1300

High Pressure Washer Pembersih Tekanan Tinggi 高压清洗机

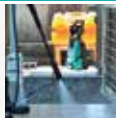

- **Eco-friendly for reduced water**
Mesra alam dengan pengurangan kegunaan air
环保与减少用水量

Standard Equipment: Trigger Gun, Vario-Power Spray Lance, Cyclone jet nozzle, Detergent Bottle, Cleaner Pin, Coupling Sleeve, High Pressure Hose 10m, Water Hose Connector, Foam Nozzle, Connector



Continuous Rating Input Input Kuasa Berterusan 额定输入功率	1,800W
Max Pressure Tekanan Maksimum 最大水压	13MPa (130bar, 1,885PSI)
Max Flow Rate Aliran Air Maksimum 最大流量	420L/h
Max Input Temperature Ketahanan Suhu Air 最大输入温度	40°C (104°F)
High Pressure Hose Length Hos Tekanan 高压软管长度	10m (33ft.)
Dimensions (L x W x H) Dimensi 体积	292x358x830mm (11-1/2"x14-1/8"x32-3/4")
Net Weight Berat Bersih 净重	12.7kg (28.0lbs.)
Power Supply Cord Kabel Wayer 电源线	5.0m (16.4ft.)

HW1200

High Pressure Washer Pembersih Tekanan Tinggi 高压清洗机



- **Uses up to 80% less water than a garden hose while delivering up to 50X the pressure**
Memberikan tekanan 50 kali ganda lebih daripada hos biasa dan menjimatkan 80% penggunaan air berbanding dengan hos biasa
用水量比园艺胶管少80%，同时可提供高达50倍的水压力

Standard Equipment: Trigger Gun, Vario-Power Spray Lance, Cyclone jet nozzle, Detergent Bottle, Cleaner Pin, Coupling Sleeve, High Pressure Hose 10m, Water Hose Connector, Foam Nozzle, Connector



Continuous Rating Input Input Kuasa Berterusan 额定输入功率	1,800W
Max Pressure Tekanan Maksimum 最大水压	12MPa (120bar, 1,740PSI)
Max Flow Rate Aliran Air Maksimum 最大流量	420L/h
Max Input Temperature Ketahanan Suhu Air 最大输入温度	40°C (104°F)
High Pressure Hose Length Hos Tekanan 高压软管长度	10m (33 ft.)
Dimensions (L x W x H) Dimensi 体积	292x358x830mm (11-1/2"x14-1/8"x32-3/4")
Net Weight Berat Bersih 净重	11.0kg (24.3lbs.)
Power Supply Cord Kabel Wayer 电源线	5.0m (16.4ft.)

HW102

High Pressure Washer Pembersih Tekanan Tinggi 高压清洗机



- **Lightweight and compact power washer for home**
Ringan dan padat, sesuai untuk kegunaan rumah
轻量家用高压清洗机



Continuous Rating Input Kuasa 额定输入功率	1,300W
Max Pressure Tekanan Maksimum 最大水压	10MPa (100bar, 1,450PSI)
Max Flow Rate Aliran Air Maksimum 最大流量	360L/h
Motor Type Enjin 马达类型	Universal
Max Input Temperature Ketahanan Suhu Air 最大输入温度	50°C (122°F)
High Pressure Hose Length Hos Tekanan 高压软管长度	5m (16.4ft.)
Net Weight Berat Bersih 净重	5.8kg (12.8lbs.)

Cordless
Terasa Keras 06.06.18

LED Flashlight
Lampu Suhu LED
LED 08.08.18.02

Vacuum Cleaner
Pembersih Vakuum
08.08.18

Drilling | Fastening
Cairul | Pengikat
08.08.18

Impact Drilling | Demolition
Cairul | Pemusnah
08.08.18 | 08.08.18

Cutting
Pemotong
08.08.18

Grinding | Sanding
Pengkilan | Polesan
08.08.18

Sawing
Cairul
08.08.18

Planing | Routing
Pecutan | Tinggung
08.08.18

Others
Lain-lain
08.08.18

Outdoor Power Equipment
Alatan Kajiha Luar
08.08.18

Makita
1915

M6501G / M6501B 6.5mm (1/4")

85

High Speed Drill

 Gerudi Kelajuan Tinggi
高速钻

- Ideal for drilling smaller holes in wood & steel
Sesuai untuk pengerudian lubang lebih kecil pada bahan kayu atau logam
适合于木材和钢材上钻孔



Standard Equipment: Chuck Key

Continuous Rating Input 230W

Input Kuasa Berterusan 额定输入功率

Capacity Steel: 6.5mm (1/4")

Kapasiti 能力

Wood: 9mm (11/32")

No Load Speed (RPM) 0 - 4,500

Kelajuan Tanpa Beban 回转数

Dimensions (L x W x H) 203x63x171mm

Dimensi 体积

Net Weight 0.95kg (2.1lbs)

Berat Bersih 净重

Power Supply Cord 2.0m (6.6ft.)

Panjang Kord 电源线

M0600B 10mm (3/8")

64

Drill

 Gerudi
电钻

- Powerful 350W motor for continuous operation
Motor berkuasa 350W untuk operasi berterusan
强力350W马达可持续运作



Standard Equipment: Chuck Key, Chuck Key Holder

Continuous Rating Input 350W

Input Kuasa Berterusan 额定输入功率

Capacity Steel: 10mm (3/8")

Kapasiti 能力

Wood: 20mm (13/16")

No Load Speed (RPM) 0 - 3,000

Kelajuan Tanpa Beban 回转数

Dimensions (L x W x H) 230x66x176mm

Dimensi 体积

Net Weight 1.2kg (2.6lbs)

Berat Bersih 净重

Power Supply Cord 2.0m (6.6ft.)

Panjang Kord 电源线

M6001B 10mm (3/8")

85

Drill

 Gerudi
电钻

- Powerful 450W motor for continuous operation
Motor berkuasa 450W untuk operasi berterusan
强力450W马达可持续运作



Standard Equipment: Chuck Key

Continuous Rating Input 450W

Input Kuasa Berterusan 额定输入功率

Capacity Steel: 10mm (3/8")

Kapasiti 能力

Wood: 25mm (1")

No Load Speed (RPM) 0 - 3,000

Kelajuan Tanpa Beban 回转数

Dimensions (L x W x H) 229x64x175mm

Dimensi 体积

Net Weight 1.3kg (2.9lbs)

Berat Bersih 净重

Power Supply Cord 2.0m (6.6ft.)

Panjang Kord 电源线

M6200G / M6200B 13mm (1/2")

303

Drill

 Gerudi
电钻

- Powerful 800W motor with variable speed for improved mixing and drilling performance
Motor berkuasa 800W dengan Pilihan kawalan kelajuan berubah untuk prestasi pencampuran dan pengerudian yang lebih baik
强力800W马达配备变速控制功率提高混合和钻孔性能



Standard Equipment: Chuck Key, Top Grip

Continuous Rating Input 800W

Input Kuasa Berterusan 额定输入功率

Capacity Steel: 13mm (1/2")

Kapasiti 能力

Wood: 36mm (1-7/16")

No Load Speed (RPM) 0 - 700

Kelajuan Tanpa Beban 回转数

Dimensions (L x W x H) 267x86x388mm

Dimensi 体积

Net Weight 2.7kg (6.0lbs.)

Berat Bersih 净重

Power Supply Cord 2.0m (6.6ft.)

Panjang Kord 电源线

M6600XG / M6600XB

303

Mixer

 Pengadun
搅拌机

- Powerful 800W motor for improved mixing and drilling performance
Motor berkuasa 800W untuk prestasi pencampuran dan pengerudian yang lebih baik
强力800W马达提高混合和钻孔性能

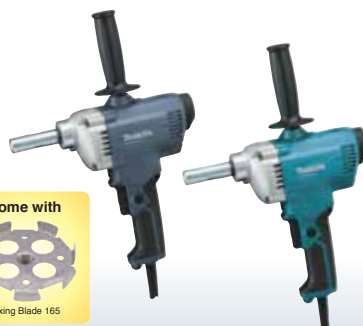

Come with



Mixing Blade 165

Standard Equipment: Mixing Blade, Shaft, Top Grip, Wrenches

Continuous Rating Input 800W

Input Kuasa Berterusan 额定输入功率

Blade Diameter 165mm (6-1/2")

Diameter Bilah 锯片直径

No Load Speed (RPM) 0 - 700

Kelajuan Tanpa Beban 回转数

Dimensions (L x W x H) 280x86x388mm

Dimensi 体积

Net Weight 2.6kg (5.7lbs.)

Berat Bersih 净重

Power Supply Cord 2.0m (6.6ft.)

Panjang Kord 电源线

M8600B 17mm (11/16") Hex Shank

105

Demolition Hammer

 Tukul Elektrik
电动锤

- Satisfactory chipping performance
Prestasi penyerpihan yang memuaskan
卓越碎击性能

Standard Equipment: Bull Point, Side Grip

M9509B
Slide Switch

Suis Gelangsar 滑动开关

M9513B
Toggle Switch

Suis Togonal 后置式开关



325

M9509B | M9513B 100mm (4")

Angle Grinder

Pengisar Sudut 角向磨光机

- Powerful 850W motor for the most demanding applications
Motor berkuasa 850W untuk aplikasi yang paling mencabar
强力850W马达适合严峻使用

 Standard Equipment: M9509B: Side Grip, Lock Nut Wrench
M9513B: Side Grip

Continuous Rating Input

Input Kuasa Berterusan 额定输入功率

850W

Wheel Diameter

Diameter Roda 轮片直径

100mm (4")

No Load Speed (RPM)

Kelajuan Tanpa Beban 回转速数

11,000

Dimensions (L x W x H)

Dimensi 体积

276x118x101mm **M9509B**273x118x101mm **M9513B**

(10-3/4"x4-5/8"x4")

Net Weight

Berat Bersih 净重

1.8kg (3.9lbs)

Power Supply Cord

Panjang Kord 电源线

2.0m (6.6ft)

459

M9506B | M9512B 100mm (4")

Angle Grinder

Pengisar Sudut 角向磨光机

- Powerful 720W motor for the most demanding applications
Motor berkuasa 720W untuk aplikasi yang paling mencabar
强力720W马达适合严峻使用

Standard Equipment: Side Grip, Lock Nut Wrench

Continuous Rating Input

Input Kuasa Berterusan 额定输入功率

720W

Wheel Diameter

Diameter Roda 轮片直径

100mm (4")

No Load Speed (RPM)

Kelajuan Tanpa Beban 回转速数

11,000

Dimensions (L x W x H)

Dimensi 体积

261x118x101mm **M9506B**

(10-1/4"x4-5/8"x4")

258x118x101mm **M9512B**

(10-1/8"x4-5/8"x4")

Net Weight

Berat Bersih 净重

1.6kg (3.6lbs)

Power Supply Cord

Panjang Kord 电源线

2.0m (6.6ft)

459

M0900B | M0910B 100mm (4")

Angle Grinder

Pengisar Sudut 角向磨光机

- High performance and durability
Prestasi dan ketahanan tinggi
高性能与持久耐用

Standard Equipment: Lock Nut Wrench

Continuous Rating Input

Input Kuasa Berterusan 额定输入功率

540W

Wheel Diameter

Diameter Roda 轮片直径

100mm (4")

No Load Speed (RPM)

Kelajuan Tanpa Beban 回转速数

12,000

Dimensions (L x W x H)

Dimensi 体积

251x118x97mm **M0900B**

(9-7/8"x4-5/8"x3-13/16")

251x118x93mm **M0910B**

(9-7/8"x4-5/8"x3-5/8")

Net Weight

Berat Bersih 净重

1.6kg (3.5lbs)

Power Supply Cord

Panjang Kord 电源线

2.0m (6.6ft)

M0900B
Top Slide Switch

 Suis Gelangsar Atas 顶部滑动开关
Convenient for left & right handed
 Mudah diguna dengan tangan
 kiri atau kanan 方便左右手

M0910B
Toggle Switch

Suis Togonal 后置式开关



M9511G / M9511B 125mm (5") 325

Angle Grinder
Pengisar Sudut
角向磨光机

Slide Switch
Suis Gelangsar 滑动开关

- **Slimmer barrel grip with easy gripping and handling**
Memberikan prestasi kawalan unggul dan keselesaan
提供更优异的控制性能和舒适度



Standard Equipment:
Side Grip, Lock Nut Wrench



Continuous Rating Input Input Kuasa Berterusan 额定输入功率	850W
Wheel Diameter Diameter Roda 轮片直径	125mm (5")
No Load Speed (RPM) Kelajuan Tanpa Beban 回转数	11,000
Dimensions (L x W x H) Dimensi 体积	276x140x111mm (10-7/8"x5-1/2"x4-3/8")
Net Weight Berat Bersih 净重	2.0kg (4.5lbs)
Power Supply Cord Panjang Kord 电源线	2.0m (6.6ft)

M9508G / M9508B 125mm (5") 459

Angle Grinder
Pengisar Sudut
角向磨光机

Slide Switch
Suis Gelangsar 滑动开关

- **Compact and lightweight for high production work**
Kompak dan ringan untuk kerja pengeluaran yang tinggi
紧凑轻巧型, 更有效率地工作



Standard Equipment:
Side Grip, Lock Nut Wrench,
Wheel Cover



Continuous Rating Input Input Kuasa Berterusan 额定输入功率	720W
Wheel Diameter Diameter Roda 轮片直径	125mm (5")
No Load Speed (RPM) Kelajuan Tanpa Beban 回转数	11,000
Dimensions (L x W x H) Dimensi 体积	261x140x111mm (10-1/4"x5-1/2"x4-3/8")
Net Weight Berat Bersih 净重	1.9kg (4.1lbs)
Power Supply Cord Panjang Kord 电源线	2.0m (6.6ft)

M9503G / M9503B 125mm (5") 411

Angle Grinder
Pengisar Sudut
角向磨光机

Top Slide Switch
Suis Gelangsar Atas 顶部滑动开关
Convenient for left & right handed
Mudah diguna dengan tangan
kiri atau kanan 方便左右手

- **Ideal for welders, fabricators, masons, maintenance/ repair and more**
Ideal untuk pengimpal, fabrikasi, tukang batu, penyelenggaraan atau pembaikan dan banyak lagi
适用于焊工, 制造商, 泥瓦匠, 维修与修理等



Standard Equipment:
Side Grip, Lock Nut Wrench



Continuous Rating Input Input Kuasa Berterusan 额定输入功率	570W
Wheel Diameter Diameter Roda 轮片直径	125mm (5")
No Load Speed (RPM) Kelajuan Tanpa Beban 回转数	11,000
Dimensions (L x W x H) Dimensi 体积	270x140x110mm (10-5/8"x5-1/2"x4-5/16")
Net Weight Berat Bersih 净重	2.0kg (4.4lbs)
Power Supply Cord Panjang Kord 电源线	2.0m (6.6ft)

M9002G / M9002B 125mm (5") 303

Angle Grinder
Pengisar Sudut
角向磨光机

Trigger Switch
Suis Pemicu 扳机开关

- **High performance and durability**
Prestasi dan ketahanan tinggi
高性能与持久耐用



Standard Equipment:
Side Grip, Lock Nut Wrench



Continuous Rating Input Input Kuasa Berterusan 额定输入功率	1,050W
Wheel Diameter Diameter Roda 轮片直径	125mm (5")
No Load Speed (RPM) Kelajuan Tanpa Beban 回转数	11,000
Dimensions (L x W x H) Dimensi 体积	361x140x124mm (14-1/4"x5-1/2"x4-7/8")
Net Weight Berat Bersih 净重	2.8kg (6.1lbs.)
Power Supply Cord Panjang Kord 电源线	2.0m (6.6ft.)

M9000G / M9000B 180mm (7") 204

Angle Grinder
Pengisar Sudut
角向磨光机

Trigger Switch
Suis Pemicu 扳机开关

- **Powerful 2,000W motor for the most demanding applications**
Motor berkuasa 2,000W untuk aplikasi yang paling mencabar
强力2,000W马达适合严峻使用



Standard Equipment:
Side Grip, Lock Nut Wrench



Continuous Rating Input Input Kuasa Berterusan 额定输入功率	2,000W
Wheel Diameter Diameter Roda 轮片直径	180mm (7")
No Load Speed (RPM) Kelajuan Tanpa Beban 回转数	8,500
Dimensions (L x W x H) Dimensi 体积	466x200x138mm (18-3/8"x7-7/8"x5-7/16")
Net Weight Berat Bersih 净重	5.4kg (12.0lbs.)
Power Supply Cord Panjang Kord 电源线	2.0m (6.6ft.)

Cordless
Tempa Kord 无绳式

LED Flashlight
Lampu Suluh LED
LED照明灯

Vacuum Cleaner
Pembersih Vakuum
吸尘器

Drilling | Fastening
Gerudi | Pengikat
钻孔 | 紧固

Impact Drilling | Demolition
Gerudi | Pemecah
石工钻孔 | 衝撃加工

Cutting
Pemotong
切割

Grinding | Sanding
Pengisar | Pelsin
研磨 | 砂磨

Sawing
Gergaji
锯切

Planing | Routing
Pergalim | Tanggaman
刨削 | 磨削

Others
Lain-lain
其他

Outdoor Power Equipment
Alatan Kerja Luar
园林/户外



Cordless
Terdapat Kord Baterai

LED Flashlight
Lampu Suhu LED
LED 照明灯

Vacuum Cleaner
Pembersih Vakum
吸尘器

Drilling | Fastening
Gerudi | Pengikat
钻孔 | 紧固

Impact Drilling | Demolition
Gerudi | Pemecah
石工钻孔 | 拆卸加工

Cutting
Pemotong
切割

Grinding | Sanding
Pengisar | Pelsih
研磨 | 砂磨

Sawing
Gergaji
锯切

Planing | Routing
Pergelam | Tanggam
刨削 | 雕刻

Others
Lain-lain
其他

Outdoor Power Equipment
Alatan Kerja Luar
园林-户外



M9001G 230mm (9")

204 W

Angle Grinder
Pengisar Sudut
角向磨光机

Trigger Switch
Suis Pemicu 扳机开关

- **Powerful 2,000W motor for the most demanding applications**
Motor berkuasa 2,000W untuk aplikasi yang paling mencabar
强力2,000W马达适合严峻使用



Standard Equipment:
Side Grip, Lock Nut Wrench



Continuous Rating Input Input Kuasa Berterusan 额定输入功率	2,000W
Wheel Diameter Diameter Roda 轮片直径	230mm (9")
No Load Speed (RPM) Kelajuan Tanpa Beban 回转数	6,600
Dimensions (L x W x H) Dimensi 体积	466x250x138mm (18-3/8"x9-7/8"x5-7/16")
Net Weight Berat Bersih 净重	5.7kg (12.6lbs.)
Power Supply Cord Panjang Kord 电源线	2.0m (6.6ft.)



M9400B 100mm (4")

153 W

Belt Sander
Pengampelas
带式砂光机

- **Powerful 940W motor for faster material removal**
Motor berkuasa 940W untuk pengisaran yang lebih cepat
功率强大的940W马达提供更快的研磨



Standard Equipment: Abrasive Belt, Dust Bag (1233280), Carbon Plate, Step



Continuous Rating Input Input Kuasa Berterusan 额定输入功率	940W
Belt Size Saiz Tali Pinggang 皮带尺寸	100 x 610mm (4" x 24")
Belt Speed Kelajuan Tali Pinggang 皮带速度	380m/min (1,250ft/min)
Dimensions (L x W x H) Dimensi 体积	354x175x169mm (14"x6-7/8"x6-5/8")
Net Weight Berat Bersih 净重	6.2kg (13.7lbs.)
Power Supply Cord Panjang Kord 电源线	2.0m (6.6ft.)

M9204G / M9204B 125mm (5")

419 W

Random Orbit Sander
Pengampelas
砂光机

- **Available with dust bag and also connectable to vacuum cleaners without adapter**
Dengan beg debu dan juga boleh disambungkan ke pembersih vakum tanpa penyesuai
配有防尘袋且可连接到没有连接器的吸尘器



Standard Equipment: Dust Bag, Abrasive Paper



Continuous Rating Input Input Kuasa Berterusan 额定输入功率	240W
Pad Size Saiz Pad 垫子尺寸	123mm (4-7/8")
Abrasive Paper Size Saiz Kertas Pasir 砂纸尺寸	125mm (5")
Orbits Per Minute (OPM) Bilangan Putaran 轨道转数	12,000
Strokes Per Minute (SPM) Kelajuan Strok 冲程速度	24,000
Orbit Diameter Jejaki Diameter 轨道直径	2.8mm (1/8")
Dimensions (L x W x H) Dimensi 体积	153x123x144mm (6"x4-7/8"x5-5/8")
Net Weight Berat Bersih 净重	1.2kg (2.6lbs)
Power Supply Cord Panjang Kord 电源线	2.0m (6.6ft)

M9202B

419

Random Orbit Sander
Pengampelas
砂光机

- **Rocker on/off switch for efficient operation**
Suis gelangsar untuk operasi yang cekap
滑动式按钮开关有效操作



Standard Equipment: Abrasive Paper



Continuous Rating Input Input Kuasa Berterusan 额定输入功率	240W
Pad Size Saiz Pad 垫子尺寸	123mm (4-7/8")
Abrasive Disc Size Saiz Cakera 磨盘尺寸	125mm (5")
Orbits Per Minute (OPM) Bilangan Putaran 轨道转速	12,000
Strokes Per Minute (SPM) Kelajuan Strok 冲程速度	24,000
Orbit Diameter Jejaki Diameter 轨道直径	2.8mm (1/8")
Dimensions (L x W x H) Dimensi 体积	127x123x142mm (5"x4-7/8"x5-5/8")
Net Weight Berat Bersih 净重	1.1kg (2.4lbs)
Power Supply Cord Panjang Kord 电源线	2.0m (6.6ft)

M9200B

419

Finishing Sander
Mesin Pengamplasan
砂光机

- **14,000OPM for fast and smooth finish sanding**
14,000OPM untuk pelicin dengan cepat
14000OPM用于快速研磨



Standard Equipment: Abrasive paper



Continuous Rating Input Input Kuasa Berterusan 额定输入功率	180W
Pad Size Saiz Pad 垫子尺寸	112 x 102mm (4-3/8" x 4")
Abrasive Paper Size Saiz Kertas Pasir 砂纸尺寸	114 x 140mm (4-1/2" x 5-1/2")
Orbits Per Minute (OPM) Bilangan Putaran 轨道转速	14,000
Dimensions (L x W x H) Dimensi 体积	110x112x133mm (4-5/16"x4-3/8"x5-1/4")
Net Weight Berat Bersih 净重	0.9kg (2lbs)
Power Supply Cord Panjang Kord 电源线	2.0m (6.6ft)

M9201B

64

Finishing Sander
Mesin Pengamplasan
砂光机

- **Compact and lightweight body for better handling**
Padat dan ringan
小巧轻便的机身易于操纵



Standard Equipment: Abrasive Paper



Continuous Rating input Input Kuasa Berterusan 额定输入功率	180W
Pad Size Saiz Pad 垫子尺寸	93 x 185mm (3-5/8" x 7-1/4")
Abrasive Paper Size Saiz Kertas Pasir 砂纸尺寸	93 x 228mm (3-5/8" x 9")
Orbits Per Minute (OPM) Bilangan Putaran 轨道转速	12,000
Dimensions (L x W x H) Dimensi 体积	214x92x147mm (8-3/8"x3-5/8"x5-3/4")
Net Weight Berat Bersih 净重	1.4kg (3.1lbs)
Power Supply Cord Panjang Kord 电源线	2.0m (6.6ft)

M5801B 185mm (7-1/4")

303

Circular Saw
Gergaji Piring
圆锯

- **High performance and durability**
Prestasi dan ketahanan tinggi
高性能兼耐用



Standard Equipment: TCT Saw Blade, Guide Rule, Hex Wrench



Continuous Rating Input Input Kuasa Berterusan 额定输入功率	1,050W
Blade Diameter Diameter Bilah 锯片直径	185mm (7-1/4")
Max Cutting Capacity Kapasiti Pemotongan Maksimum 最大切割能力	90°: 66mm (2-5/8") 45°: 44mm (1-3/4")
No Load Speed (RPM) Kelajuan Tanpa Beban 回转速数	4,900
Dimensions (L x W x H) Dimensi 体积	284x231x243mm (11-1/8"x9-1/8"x9-9/16")
Net Weight Berat Bersih 净重	3.7kg (8.1lbs)
Power Supply Cord Panjang Kord 电源线	2.0m (6.6ft.)

M2300B 255mm (10")

JM23000123

Compound Miter Saw
Gergaji Kompaun Miter
斜断锯

- **Powerful 1,500W motor**
Motor berkuasa 1,500W
强力1,500W马达



Standard Equipment: Wrench, Dust Bag, Triangular Rule, Vise Assembly, Set Plate, Vercicle Vise



Continuous Rating Input Input Kuasa Berterusan 额定输入功率	1,500W
Blade Diameter Diameter Bilah 锯片直径	255mm (10")
Miter Angle Sudut Miter 斜接角	45°L/ 45°R
Bevel Angle Sudut Bevel 斜角	45°L
Max Cutting Capacity Kapasiti Pemotongan Maksimum 最大切割能力	90° Miter: 75 x 130mm (2-15/16" x 5-1/8") 45° Miter, L/R: 75 x 90mm (2-15/16" x 3-9/16")
No Load Speed (RPM) Kelajuan Tanpa Beban 回转速数	4,200
Dimensions (L x W x H) Dimensi 体积	610x485x515mm (24"x19-1/8"x20-1/4")
Net Weight Berat Bersih 净重	14.7kg (32.5lbs)
Power Supply Cord Panjang Kord 电源线	2.5m (8.2ft)

Cordless
Tempat Kord 无绳式

LED Flashlight
Lampu Suluh LED
LED照明灯

Vacuum Cleaner
Pembersih Vakuum
吸尘器

Drilling | Fastening
Cecuri | Pengikat
钻孔 | 紧固

Impact Drilling | Demolition
Gerudi | Pemecah
石工钻孔 | 爆破加工

Cutting
Pemotong
切割

Grinding | Sanding
Pengisar | Pelsin
研磨 | 砂磨

Sawing
Gergaji
锯切

Planing | Routing
Pengaliran | Tanggaman
刨削 | 雕刻

Others
Lain-lain
其他

Outdoor Power Equipment
Alatan Kerja Luar
园林户外

M4302B

411

Jig Saw

Gergaji Jig
线锯机

- Heavy duty aluminum gear housing for increased durability
Gear aluminium tugas berat untuk meningkatkan ketahanan
重型铝制齿轮组件结构提高耐用性



Standard Equipment: 2x Jig Saw Blade (B-13 & No. 51), Hex Wrench



Continuous Rating Input Input Kuasa Berterusan 额定输入功率	450W
Max Cutting Capacity at 90° Kapasiti Pemotongan Maksimum 最大切割能力	Wood: 55mm (2-3/16") Steel: 6mm (1/4")
Length of Stroke Panjang Strok 冲程长度	26mm (1")
Strokes Per Minute (SPM) Kelajuan Strok 冲程速度	0 - 3,100
Dimensions (L x W x H) Dimensi 体积	219x85x191mm (8-5/8"x3-3/8"x7-1/2")
Net Weight Berat Bersih 净重	2.5kg (5.5lbs.)
Power Supply Cord Panjang Kord 电源线	2.0m (6.6ft.)

M4301B

64

Jig Saw

Gergaji Jig
线锯机

- Powerful 450W motor
Motor berkuasa 450W
强力450W马达



Standard Equipment: Jig Saw Blade (B-10), Hex Wrench



Continuous Rating Input Input Kuasa Berterusan 额定输入功率	450W
Max Cutting Capacity at 90° Kapasiti Pemotongan Maksimum 最大切割能力	Wood: 65mm (2-9/16") Steel: 6mm (1/4")
Length of Stroke Panjang Strok 冲程长度	18mm (11/16")
Strokes Per Minute (SPM) Kelajuan Strok 冲程速度	0 - 3,100
Dimensions (L x W x H) Dimensi 体积	214x75x202mm (8-3/8"x2-15/16"x8")
Net Weight Berat Bersih 净重	1.9kg (4.1lbs)
Power Supply Cord Panjang Kord 电源线	2.0m (6.6ft.)

M4501G / M4501B

303

Recipro Saw

Gergaji Resipro
往复锯

- Powerful 1,010W motor for improved performance
Motor berkuasa 1,010W untuk prestasi lebih baik
强劲的1.010W马达提高性能



Continuous Rating Input Input Kuasa Berterusan 额定输入功率	1,010W
Length of Stroke Panjang Strok 冲程长度	28mm (1-1/8")
Strokes Per Minute (SPM) Kelajuan Strok 冲程速度	0 - 2,800
Capacity Kapasiti 能力	Pipe : 130mm (5-1/8") Wood: 255mm (10")
Dimensions (L x W x H) Dimensi 体积	457x98x170mm (18"x3-7/8"x6-11/16")
Net Weight Berat Bersih 净重	3.2kg (7lbs)
Power Supply Cord Panjang Kord 电源线	2.0m (6.6ft.)

M0400B 110mm (4-3/8")

303

Cutter

Pemotong
切割机

- Powerful 1,200W motor
Motor berkuasa 1,200W
强力1.200W马达



Standard Equipment: Wrench, Hex Wrench
(Tool does not come with Diamond Wheel)



Continuous Rating Input Input Kuasa Berterusan 额定输入功率	1,200W
Blade Diameter Diameter Bilah 锯片直径	110mm (4-3/8")
Max Cutting Capacity Kapasiti Pemotongan Maksimum 最大切割能力	90°: 32mm (1-1/4")
No Load Speed (RPM) Kelajuan Tanpa Beban 回转数	13,800
Dimensions (L x W x H) Dimensi 体积	224x195x164mm (8-7/8"x7-5/8"x6-1/2")
Net Weight Berat Bersih 净重	2.5kg (5.6lbs.)
Power Supply Cord Panjang Kord 电源线	2.0m (6.6ft.)

M4100G / M4100B 110mm (4-3/8")

303

Cutter

Pemotong
切割机

- Compact and lightweight for reduced operator fatigue
Kompak dan ringan untuk mengurangkan keletihan pengguna
小巧轻便, 减少疲劳



Standard Equipment: Wrench, Hex Wrench, Water Supply Set
(Tool does not come with Diamond Wheel)



Continuous Rating Input Input Kuasa Berterusan 额定输入功率	1,200W
Blade Diameter Diameter Bilah 锯片直径	110mm (4-3/8")
Max Cutting Capacity Kapasiti Pemotongan Maksimum 最大切割能力	90°: 32mm (1-1/4")
No Load Speed (RPM) Kelajuan Tanpa Beban 回转数	13,000
Dimensions (L x W x H) Dimensi 体积	227x209x166mm (8-15/16"x8-1/4"x6-1/2")
Net Weight Berat Bersih 净重	2.9kg (6.4lbs)
Power Supply Cord Panjang Kord 电源线	2.0m (6.6ft.)

M2401B 355mm (14")

203

Portable Cut-off
Mesin Pemotong
型材切割机

- **Large cutting capacity;**
Cuts up to 127mm (5") round and 102mm (4") x 194mm (7-5/8") rectangular
Kapasiti pemotongan tinggi
切割能力高



Standard Equipment: Abrasive Cut-Off Wheel, Hex Wrench



Continuous Rating Input Input Kuasa Berterusan 额定输入功率	2,000W
Wheel Diameter Diameter Roda 轮片直径	355mm (14")
No Load Speed (RPM) Kelajuan Tanpa Beban 回转数	3,800
Dimensions (L x W x H) Dimensi 体积	500x280x620mm (19-3/4"x11"x24-3/8")
Net Weight Berat Bersih 净重	13.7kg (30.2lbs.)
Power Supply Cord Panjang Kord 电源线	2.5m (8.2ft.)

M2403B 355mm (14")

203

Portable Cut-off
Mesin Pemotong
型材切割机

- **High performance and durability at less expense**
Prestasi dan ketahanan tinggi dengan kos yang lebih rendah
以更低的成本获得高性能兼耐用



Standard Equipment: Cut-Off Wheel, Hex Wrench



Continuous Rating Input Input Kuasa Berterusan 额定输入功率	2,200W
Wheel Diameter Diameter Roda 轮片直径	355mm (14")
No Load Speed (RPM) Kelajuan Tanpa Beban 回转数	3,900
Dimensions (L x W x H) Dimensi 体积	515x280x640mm (20-1/4"x11"x25-1/4")
Net Weight Berat Bersih 净重	13.8 - 15.3kg (30.4 - 33.7lbs.)
Power Supply Cord Panjang Kord 电源线	2.5m (8.2ft.)

M1100G / M1100B 82mm (3-1/4")

303

Planer
Planer
电刨

- **Easy blade setting system for fast blade installation**
Sistem pemasangan bilah mudah
刀片易安装系统



Standard Equipment: Planer Blade, Sharpening Holder Assembly (for resharpenable blade), Blade Gauge, Socket Wrench, Guide Rule



Continuous Rating Input Input Kuasa Berterusan 额定输入功率	750W
Planing Width Lebar Pelan 刨削宽度	82mm (3-1/4")
Planing Depth Kedalaman Pelan 刨削深度	3mm (1/8")
No Load Speed (RPM) Kelajuan Tanpa Beban 回转数	18,000
Dimensions (L x W x H) Dimensi 体积	390x175x140mm (15-3/8"x6-7/8"x5-1/2")
Net Weight Berat Bersih 净重	4.6kg (10.2lbs.)
Power Supply Cord Panjang Kord 电源线	2.0m (6.6ft.)

M1901B | M1902B 82mm (3-1/4")

411

Planer
Planer
电刨

- **High performance and durability**
Prestasi dan ketahanan tinggi 高性能兼耐用



Standard Equipment:
M1901B: Planer Blade, Sharpening Holder Assembly (for resharpenable blade), Blade Gauge, Socket Wrench, Guide Rule

M1902B: Planer Blade, Sharpening Holder Assembly (for resharpenable blade), Blade Gauge, Guide Rule



Continuous Rating Input Input Kuasa Berterusan 额定输入功率	580W
Planing Width Lebar Pelan 刨削宽度	82mm (3-1/4")
Planing Depth Kedalaman Pelan 刨削深度	2mm (1/16") M1901B 1mm (1/32") M1902B
No Load Speed (RPM) Kelajuan Tanpa Beban 回转数	16,000
Dimensions (L x W x H) Dimensi 体积	285x157x160mm (11-1/4"x6-3/16"x6-5/16")
Net Weight Berat Bersih 净重	2.8 - 2.9kg (6.1 - 6.4lbs)
Power Supply Cord Panjang Kord 电源线	2.0m (6.6ft)

M3600G / M3600B 12mm (1/2")

203

Router
Pemangkas
雕刻机

- **Conveniently located plunge lock lever for efficient operation**
Pelarasan tui yang mudah untuk operasi yang cekap
便利的插入式锁定杆可实现高效操作



Standard Equipment: Straight Guide, Templet Guide, Guide Holder, Collet Sleeve, Straight Bit, Wrench



Continuous Rating Input Input Kuasa Berterusan 额定输入功率	1,650W
Collet Capacity Kapasiti Collet 夹头直径	12mm (1/2")
Plunge Capacity Kapasiti Plunge 能力	0 - 60mm (0 - 2-3/8")
No Load Speed (RPM) Kelajuan Tanpa Beban 回转数	22,000
Dimensions (L x W x H) Dimensi 体积	284x148x300mm (11-1/8"x5-7/8"x11-3/4")
Net Weight Berat Bersih 净重	5.5kg (12.2lbs.)
Power Supply Cord Panjang Kord 电源线	2.0m (6.6ft.)

Cordless
Tempa Kord 无绳式

LED Flashlight
Lampu Suluh LED
LED照明灯

Vacuum Cleaner
Pembersih Vakuum
吸尘器

Drilling | Fastening
Cecak | Pengikat
钻孔 | 紧固

Impact Drilling | Demolition
Gerudi | Pemecah
石工钻孔 | 衝撃加工

Cutting
Pemotong
切割

Grinding | Sanding
Pengisar | Pelsin
研磨 | 砂磨

Sawing
Gergaji
锯切

Planing | Routing
Pengaliran | Tanggaman
刨削 | 雕刻

Others
Lain-lain
其他

Outdoor Power Equipment
Alatan Kerja Luar
园机/户外



Cordless
Tanpa Kord Listrik

LED Flashlight
Lampu Suhu LED
LED 照明灯

Vacuum Cleaner
Pembersih Vakum
吸尘器

Drilling | Fastening
Gerudi | Pengikat
钻孔 | 紧固

Impact Drilling | Demolition
Gerudi | Pemecah
石工钻孔 | 拆除加工

Cutting
Pemotong
切割

Grinding | Sanding
Pengisar | Pelsih
研磨 | 打磨

Sawing
Gergaji
锯切

Planing | Routersing
Pengalir | Tanggam
刨削 | 磨削

Others
Lain-lain
其他

Outdoor Power Equipment
Alat-alat Kerja Luar
园林·户外



M3601B 6mm (1/4"), 8mm (3/8")

106 W

Router
Pemangkas
雕刻机

- **Powerful 900W motor**
Motor berkuasa 900W
强力900W马达



Standard Equipment: Straight Guide,
Straight Bit (733238-9), Wrench



Continuous Rating Input Input Kuasa Berterusan 额定输入功率	900W
Collet Capacity Kapasiti Collet 夹头直径	6 mm (1/4") 8 mm (3/8")
Plunge Capacity Kapasiti Plunge 能力	0 - 35mm (0 - 1-3/8")
No Load Speed (RPM) Kelajuan Tanpa Beban 回转数	27,000
Dimensions (L x W x H) Dimensi 体积	256x110x218mm (10-1/8"x4-5/16"x8-5/8")
Net Weight Berat Bersih 净重	2.7kg (6.0lbs)
Power Supply Cord Panjang Kord 电源线	2.0m (6.6ft)

M3602B 12mm (1/2")

203 W

Router
Pemangkas
雕刻机

- **Powerful 1,650 W motor delivers 22,000 RPM for the most demanding applications**



Standard Equipment: Straight Guide, Templet Guide,
Trimmer Guide, Guide Holder, Collet Sleeve, Straight Bit, Wrench



Continuous Rating Input Input Kuasa Berterusan 额定输入功率	1,650W
Collet Capacity Kapasiti Collet 夹头直径	12mm (1/2")
Plunge Capacity Kapasiti Plunge 能力	0 - 60mm (0 - 2-3/8")
No Load Speed (RPM) Kelajuan Tanpa Beban 回转数	22,000
Dimensions (L x W x H) Dimensi 体积	148x284x300mm (5-7/8"x11-1/8"x11-3/4")
Net Weight Berat Bersih 净重	5.7kg (12.6lbs.)
Power Supply Cord Kabel Wayar 电源线	2.0m (6.6ft)

M9800B

459 W

Multi Tool
Mesin Pemotong Berbilang Fungsi
多功能切割打磨机

- **Lightweight Design**
Reka bentuk yang padat dan ringan
紧凑轻巧的设计



Standard Equipment: Hex Wrench



Oscillations Per Minute (OPM) Kelajuan Ayunan 摆动速度	15,000 - 22,000
Oscillation Angle Sudut Ayunan 摆动角度	Left: 1.6° Right: 1.6° Total: 3.2°
Dimensions (L x W x H) Dimensi 体积	283x68x98mm (11-1/8"x2-11/16"x3-7/8")
Net Weight Berat Bersih 净重	1.2 - 1.3kg (2.7 - 3.0 lbs.)
Power Supply Cord Panjang Kord 电源线	2.0m (6.6ft)



M3700B 6mm (1/4")

411

Trimmer
 Mesin Perapi
 修边雕刻机

- Compact and lightweight body for better handling
 Padat dan ringan
 小巧轻便的机身易于操纵

Standard Equipment: Trimmer Guide, Straight Guide, Templet Guide, Straight Bit, Chip Deflector, Wrench

Continuous Rating Input Input Kuasa Berterusan 额定输入功率	530W
Collet Capacity Kapasiti Collet 夹头直径	6mm or 1/4"
Plunge Capacity Kapasiti Plunge 铣削能力	0 - 42mm (0 - 1-5/8")
No Load Speed (RPM) Kelajuan Tanpa Beban 回转数	35,000
Dimensions (L x W x H) Dimensi 体积	82x90x199mm (3-1/4"x3-1/2"x7-7/8")
Net Weight Berat Bersih 净重	1.4kg (3.1lbs.)
Power Supply Cord Panjang Kord 电源线	2.0m (6.6ft.)

M3701G / M3701B 6mm (1/4")

411

Trimmer
 Mesin Perapi
 修边雕刻机

- Aluminium housing for higher durability
 Cangkang aluminium untuk ketahanan yang lebih tinggi
 铝外壳更高的耐用性

Standard Equipment: Trimmer Guide, Straight Guide Assembly, Templet Guide, Straight Bit (733238A9), Chip Deflector, Wrench

Continuous Rating Input Input Kuasa Berterusan 额定输入功率	530W
Collet Capacity Kapasiti Collet 夹头直径	6mm or 1/4"
Plunge Capacity Kapasiti Plunge 铣削能力	0 - 42mm (0 - 1-5/8")
No Load Speed (RPM) Kelajuan Tanpa Beban 回转数	35,000
Dimensions (L x W x H) Dimensi 体积	82x90x199mm (3-1/4"x3-1/2"x7-7/8")
Net Weight Berat Bersih 净重	1.6kg (3.4lbs.)
Power Supply Cord Panjang Kord 电源线	2.0m (6.6ft.)

M3702B 6mm (1/4")

411

Trimmer
 Mesin Perapi
 修边雕刻机

- Super smooth rack-and-pinion depth adjustment

Standard Equipment: Collet Cone, Trimmer Guide, Straight Guide Assembly, Templet Guide, Straight Bit, Chip Deflector, Wrench

Continuous Rating Input Input Kuasa Berterusan 额定输入功率	530W
Collet Capacity Kapasiti Collet 夹头直径	6mm or 1/4"
Plunge Capacity Kapasiti Plunge 铣削能力	0 - 42mm (0 - 1-5/8")
No Load Speed (RPM) Kelajuan Tanpa Beban 回转数	35,000
Dimensions (L x W x H) Dimensi 体积	82x90x211mm (3-1/4"x3-1/2"x8-5/16")
Net Weight Berat Bersih 净重	1.5kg (3.3lbs.)
Power Supply Cord Panjang Kord 电源线	2.0m (6.6ft.)

M4000B

85

Blower
 Mesin Blower
 吹风机

- Compact and lightweight increased operator comfort
 Kompak dan ringan operasi yang selesa
 小巧轻便操作舒适

Standard Equipment: Nozzle Assembly, Sash Nozzle

Continuous Rating Input Input Kuasa Berterusan 额定输入功率	530W
Air Volume Isipadu Angin 风量	1.2-2.9m³/min
No Load Speed (RPM) Kelajuan Tanpa Beban 回转数	8,500 - 16,000
Dimensions (L x W x H) Dimensi 体积	427x161x212mm (16-3/4"x6-3/8"x8-3/8")
Net Weight Berat Bersih 净重	1.5kg (3.4lbs)
Power Supply Cord Panjang Kord 电源线	2.0m (6.6ft)

M4001G / M4001B

303

Blower
 Mesin Blower
 吹风机

- Two tools in one; quickly converts to a vacuum for added versatility
 Alat 2 dalam 1, vakum dan blower untuk fleksibiliti tambahan
 一机2用, 集尘与吹风

Standard Equipment: Nozzle, Dust Bag

Continuous Rating Input Input Kuasa Berterusan 额定输入功率	600W
Max Air Volume Isipadu Angin Maksimum 最大风量	0 - 4.1m³/min
Max Air Velocity Velositi Angin Maksimum 最大风速	0 - 91m/s
Air Pressure Tekanan Udara 气压	0 - 5.7kPa
No Load Speed (RPM) Kelajuan Tanpa Beban 回转数	0 - 16,000
Dimensions (L x W x H) Dimensi 体积	480x185x178mm (18-7/8"x7-1/4"x7")
Net Weight Berat Bersih 净重	1.9 - 2.0kg (4.3 - 4.5lbs)
Power Supply Cord Panjang Kord 电源线	2.0m (6.6ft.)

 Cordless
 Tanpa Kord 无绳式

 LED Flashlight
 Lampu Suluh LED
 LED照明灯

 Vacuum Cleaner
 Pembersihkan Vakum
 吸尘器

 Drilling | Fastening
 Gerudi | Pengikat
 钻孔 | 紧固

 Impact Drilling | Demolition
 Gerudi | Pemecah
 石工钻孔 | 凿裂加工

 Cutting
 Pemotong
 切割

 Grinding | Sanding
 Pengisar | Pelsin
 研磨 | 打磨

 Sawing
 Gergaji
 锯切

 Planing | Routing
 Pengaliran | Tanggaman
 刨削 | 雕刻

 Others
 Lain-lain
 其他

 Outdoor Power Equipment
 Alatan Kerja Luar
 园林/户外



Makita Malaysia



Scan for our location
Imbas untuk lokasi kami
扫描位置地图

Makita Corporation was founded in 1915 as an electric motor sales and repair company. Makita has grown to become Japan's top manufacturer of portable power tools and recognized leader globally. In May 2013, Makita Malaysia Sales Subsidiary was established in Subang Jaya to provide the best service to cater and satisfy the increased demand and needs of Makita product range in the market. As a cordless tools company, we have the widest range of DC Cordless tools in the market. We envisioned a zero emission working environment with our wide range of DC Cordless Outdoor Power Equipment (DC Cordless OPE), as well as a clean and dustless working environment through our wide range of DC Cordless Cleaner & Vacuum Series. Utilizing the Compact eXtreme Technology (CXT) and Lithium-Ion eXtreme Technology (LXT) in our wide range of DC Cordless tools brings superb and durable performance for professional needs.

Makita Corporation ditubuhkan pada tahun 1915 sebagai syarikat jualan dan pembaikan motor elektrik. Makita telah berkembang menjadi pengilang utama alat-alat kuasa mudah alih dan pemimpin diiktiraf di peringkat global. Pada bulan Mei 2013, Subsidi Jualan Makita Malaysia ditubuhkan di Subang Jaya untuk menyediakan perkhidmatan terbaik untuk memenuhi permintaan pengguna dan memenuhi keperluan produk Makita di pasaran. Sebagai sebuah syarikat jualan peralatan tanpa kord, kami mengimpikan suasana kerja tanpa pencemaran melalui peralatan aktiviti kerja luar Lithium-ion (Li-ion OPE). Tambahan pula, ia menjadikan persekitaran kerja yang bersih dan tanpa habuk dengan Siri Peralatan Pembersihan kami. Teknologi eXtreme Compact (CXT) dan Teknologi Lithium-ion eXtreme (LXT) dicipta untuk alatan tanpa kord berprestasi tinggi dan tahan lama supaya memenuhi kehendak golongan profesional.

牧田公司成立于1915年，是一家电动机销售和维修公司。牧田已发展成为日本最大的便携式电动工具制造商，并且是全球公认的领导着。2013年5月，牧田马来西亚销售子公司在梳邦再也成立，以提供最佳服务以满足市场上对牧田产品不断增长的需求。通过一系列的锂电园林与户外工具 (Li-ion OPE)，我们致力于实现无排气的工作环境，我们的吸尘器系列，确保各类工业维持干净且无尘的工作环境。我们采用紧凑型极限技术 (CXT) 和锂离子技术 (LXT)，为专业需求打造高效率耐用性高的充电式工具。

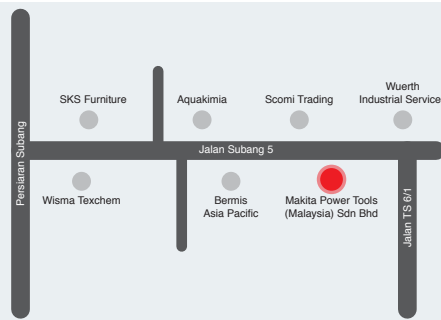

HQ & Service Centre

总部和服务与展示中心

Lot 824, Jalan Subang 5,
Subang Industrial Area,
47500 Subang Jaya, Selangor.
Tel: 03-8023 0824 (General) | Fax: 03-8022 1448
03-8022 1443 (Service)

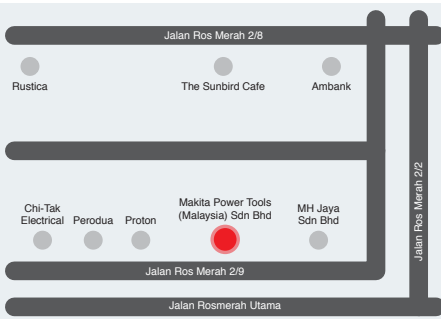

Johor (Johor Bahru) Service Centre

柔佛 (新山) 服务与展示中心

No.12 & 14, Jalan Rosmerah 2/9,
Taman Johor Jaya,
81100 Johor Bahru, Johor.
Tel: 07-364 9406 | Fax: 07-364 9407

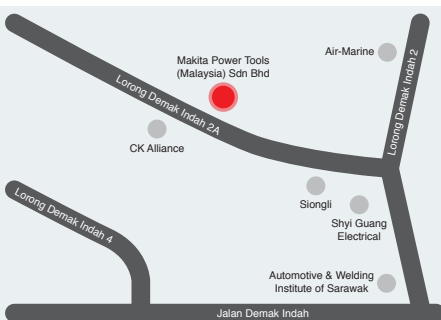

Sarawak (Kuching) Service Centre

砂拉越 (古晋) 服务与展示中心

Lot 1227, Lorong Demak Indah 2A,
Demak Laut Industrial Area, Phase 2A,
93050 Kuching, Sarawak.
Tel: 082-496 800 | Fax: 082-496 900



Sabah (Kota Kinabalu) Service Centre

沙巴 (亚庇) 服务与展示中心

Lot 19, Jalan Buah Duku,
Kolombong Light Industrial Estate,
Off Kolombong, Kolombong Zone 1,
88450 Inanam, Kota Kinabalu, Sabah.
Tel: 088-388 278 | Fax: 088-388 279



Schedule an **On-site Demonstration** for your team!



We are happy to visit your office for on-site demonstrations focusing on 320+ DC tools at your convenience. Our professional technicians will introduce suitable DC tools that match your requirements, demonstrate correct operation on site and advise on maintenance of Makita DC tools. Get in-depth understanding how Makita latest DC tools and technologies could benefit your organisation, "hands-on" to try Makita DC tools to experience the Extreme Cordless Power!

Kami gembira untuk melawat tapak kerja anda untuk demonstrasi kepada 300+ alat kuasa tanpa kord. Juruteknik profesional kami sedia untuk memperkenalkan alat kuasa tanpa kord yang sesuai, menunjukkan kaedah operasi yang betul di tapak kerja dan memberi panduan kaedah penyelenggaraan alat kuasa tanpa kord Makita. Ketahui lebih lanjut tentang bagaimana alat kuasa tanpa kord dan teknologi terbaru Makita dapat memberi manfaat kepada organisasi anda, "hands-on" cuba alat kuasa tanpa kord Makita untuk mengalami Kuasa Tanpa Kord Extreme!

本公司拥有流动示范服务车，我们的专业技术人员会亲身到访问下的工作场地，向阁下介绍合适的充电式工具，现场示范正确的操作方法及指导关于 Makita 充电式工具的日常保养方法等。深入了解 Makita 最新的充电式工具和技术，试用 Makita 的充电式工具，亲身体验 Extreme Cordless Power!



On site Demo Hotline

West Malaysia

East Malaysia

HQ & Service Centre
总部和服务与展示中心

03-8023 0824

Sabah (Kota Kinabalu) Service Centre
沙巴(亚庇)服务与展示中心

088-388 278

Johor (Johor Bahru) Service Centre
柔佛(新山)服务与展示中心

07-364 9406

Sarawak (Kuching) Service Centre
砂拉越(古晋)服务与展示中心

082-496 800

Roadshow and Demonstration

Join us at our roadshow for countless demonstrations on our latest tools and technologies. "Hands-on" to try Makita DC tools to experience the Extreme Cordless Power!

Sila kunjungi Roadshow kami untuk demonstrasi mengenai alat kuasa tanpa kord dan teknologi terkini, "hands-on" cuba alat kuasa tanpa kord Makita untuk mengalami Kuasa Tanpa Kord Extreme!

请到访我们的展销会，深入了解 Makita 最新的充电式工具和技术，试用 Makita 的充电式工具，亲身体验 Extreme Cordless Power!



Health and Safety Seminar

As a responsible professional power tool manufacturer, Makita always concerns about the health and safety issues of workers. Apart from developing products with specific safety features, we also organize workplace health and safety seminars for organisations.

Sebagai pengeluar alat kuasa profesional yang bertanggungjawab, Makita selalu mengambil berat tentang kesihatan dan keselamatan pekerja. Selain mengembangkan produk dengan ciri keselamatan khusus, kami juga mengadakan seminar untuk organisasi mengenai kesihatan dan keselamatan di tempat kerja.

Makita 作为一家负责任的专业电动工具生产商，一直都很关注工人的健康及安全。除了开发具有特定安全功能的产品，我们还为不同团体或公司举办有关工作场所健康与安全的讲座会。





12 MONTHS WARRANTY

Waranti 12 bulan • 12个月保修期

* Applicable on all Makita Tools, except heat gun (period of 6 months warranty)

* Untuk semua Makita Tool, kecuali Heat Gun (waranti 6 bulan) | *有效于所有 Makita 工具, 热风机除外 (享有6个月保修)

Makita Standard Warranty

Piawaian Waranti Makita • Makita 保修服务说明

Every Makita Product is thoroughly inspected and tested before leaving the factory. Subject to the following terms and conditions, the Product (Tool, Battery, Charger) is warranty against defective materials and manufacturing defects for a period of twelve (12) months from the date of purchase (applicable for purchases made from 1st October 2017 onwards) as evidenced from the sale or tax invoice (with tool serial number) and Makita Authorised Service Centre or Makita Service Centre undertakes, at our option, to repair or replace, free of charge.

Conditions of warranty

This warranty will NOT cover or shall be null & void in any of the following events even during the warranty period:-

1. Damage resulting from normal wear and tear (Carbon brush/ holder/ cap, switch, gear, grinding/ cutting wheels, bits, saw blades, etc..)
2. Damage resulting from use of improper accessories, non genuine replacement parts, disassembly, tampering, alteration and repairing in any way that affects its performance.
3. Damage resulting from negligence, accident, disaster, improper storage or maintenance, abuse and misuse in evident caused by overloading the tool beyond its capacity.
4. Abnormal voltage or the usage of generator, wrong usage not in accordance with the Operating Manual.
5. If the serial number on the tool, seal on the battery and charger has been defaced or removed.
6. If the receipt or invoice that display the date of purchase could not be present.

Setiap produk Makita diperiksa dan diuji dengan teliti dari kilang. Waranti produk (Alat, Bateri, Pengecas Bateri) tertakluk kepada terma dan syarat berikut, sekiranya terdapat kecacatan pada bahan atau kerosakan disebabkan pemuatan dari kilang dalam tempoh 12 bulan bermula dari tarikh pembelian (untuk pembelian bermula dari 1hb Oktober 2017), dengan bukti pembelian pada resit atau invoice bercukai (dengan nombor siri alat), terikat kepada keputusan Pusat Servis Diiktiraf oleh Makita atau Pusat Servis Makita untuk membaiki secara percuma.

Syarat-syarat waranti

Waranti ini TIDAK akan meliputi atau akan dibatalkan & tidak sah sekiranya berlaku salah satu kejadian yang berikut semasa berada dalam tempoh waranti:-

1. Kerosakan akibat daripada haus dan lusuh biasa (karbon/ pemegang/ tukup, suis, gear, cakera mencanai/ memotong, mata gerudi, bilah gergaji, dll..)
2. Kerosakan akibat daripada penggunaan aksesori yang tidak sesuai, alat ganti yang tidak asli, pembukaan, perbuatan merosakkan, pengubahan dan pembaikan yang mempengaruhi prestasinya.
3. Kerosakan akibat kecuai, kemalangan, bencana, penyimpanan atau penyelenggaraan yang tidak wajar, penyalahgunaan yang jelas disebabkan oleh beban yang melebihi kemampuannya.
4. Voltan tidak normal atau penggunaan penjana, cara penggunaan yang salah dan tidak mengikut Manual Operasi.
5. Jika nombor siri pada alat, balut/ cap pada bateri dan pengecas tercacat atau ditanggalkan.
6. Jika resit atau invoice yang memaparkan tarikh pembelian tidak dapat ditunjukkan.

每个 Makita 产品生产制造都经过彻底检查和测试并严格把关确认品质。根据以下保修条件, 产品保修 (工具, 电池, 充电器) 涵盖材质和生产上的瑕疵, 于销售单据 (附上工具生产编号) 与税收发票上所显示的购买日期起十二 (12) 个月内 (从1-10-2017选购开始), 以 Makita 授权服务中心或 Makita 服务中心的判断为准而提供无收费维修。

保修规定

Makita 均不承担基于以下违反保修行为而造成的产品故障、工作异常或损坏的责任。

1. 正常消耗零件。(例如: 碳刷/支架/盖, 开关, 齿轮, 研磨/切割片, 钻头, 锯片等)。
2. 使用不正确的配件, 更换非原装零件, 拆除和改造等任何影响其性能而引起的损坏。
3. 因人为疏忽, 意外, 灾难, 不正确的保管或保养, 滥用和误用, 超出工具负荷能力等原因导致的损坏。
4. 使用非工具所规定电压和发电机, 未按说明书安装及使用工具。
5. 工具上的编号, 电池和充电器上的印章已被污损或除去。
6. 无法提供销售单据或税收发票。

** Makita reserved the rights of amend conditions of warranty without prior notice. In the event of differences arising between the English, Bahasa Malaysia and Chinese versions, the English version shall prevail.
Makita berhak untuk meminda syarat-syarat waranti pada bila-bila masa tanpa sebarang notis. Jika terdapat perbezaan antara bahasa, maka maklumat versi Bahasa Inggeris harus digunapakai.
Makita 保留修改保修规定的权利, 恕不另行通知。如果内容有任何差异或不一致, 概以英文版本为准。



Please visit our website for contact of nearest
AUTHORISED SERVICE CENTRE
www.makita.my/Customer-Services/

Sila layari laman web kami untuk maklumat Pusat Servis Diiktiraf
请游览我们的网页以获取授权服务中心的详细信息



MAKITA SERVICE CENTRE
SERVIS & BAIK-PULIH 售后服务及维修
www.makita.my/makita-service-centre/



PRODUCT RANGE
SIRI PRODUK 产品系列
www.makita.my/cordless-tools-batteries/



ACCESSORIES
AKSESORI 配件
www.makita.my/accessories/



ABOUT US
MENGENAI KAMI 公司简介
www.makita.my/makita-malaysia/



LATEST INFO & PROMOTION
INFO & PROMOSI TERKINI 最新信息和促销
www.makita.my/news-events/



E-CATALOGUE
KATALOG PRODUK 商品目录
<https://www.makita.my/catalogue/>





Like us on Facebook
MAKITA MALAYSIA

Makita Power Tools (Malaysia) Sdn. Bhd. Co. Registration No.: 201301001778 (1031615-M)

HQ & Service Centre
总部与服务与展示中心
Lot 824, Jalan Subang 5, Subang Industrial Area,
47500 Subang Jaya, Selangor.
Tel: 03-8023 0824 (General) | Fax: 03-8022 1448
03-8022 1443 (Service)

Johor (Johor Bahru) Service Centre
柔佛 (新山) 服务与展示中心
No.12 & 14, Jalan Rosmerah 2/9,
Taman Johor Jaya,
81100 Johor Bahru, Johor.
Tel: 07-364 9406 | Fax: 07-364 9407

Sarawak (Kuching) Service Centre
砂拉越 (古晋) 服务与展示中心
Lot 1227, Lorong Demak Indah 2A,
Demak Laut Industrial Area, Phase 2A,
93050 Kuching, Sarawak.
Tel: 082-496 800 | Fax: 082-496 900

Sabah (Kota Kinabalu) Service Centre
沙巴 (亚庇) 服务与展示中心
Lot 19, Jalan Buah Duku,
Kolombong Light Industrial Estate, Off Kolombong,
Kolombong Zone 1, 88450 Inanam, Kota Kinabalu, Sabah.
Tel: 088-388 278 | Fax: 088-388 279

12 MONTHS WARRANTY
Warranty 12 bulan • 12 个月保修期



www.makita.my
makita@makita.my